

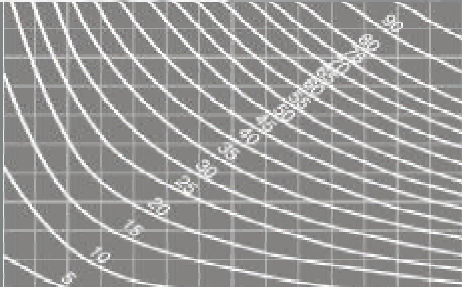

**Schlumberger**

Completions Hydraulics  
Handbook



**American Edition**



## ***INTRODUCTION***

This version of the "Hydraulics Calculation Handbook" uses American units of measurements only.

This publication is intended for use by SCHLUMBERGER field personnel. This handbook is designed to be an educational as well as a reference handbook.

If requested, SCHLUMBERGER will supply copies of this publication to persons or groups who in our opinion would have an application for this publication.

# Schlumberger

The designs, illustrations and specifications contained in this publication are proprietary and provided for reference only and may not be copied in any form without the express written consent of Schlumberger.

While considerable effort has been made to ensure the accuracy of the technical data in this handbook, no warranty is expressed or implied in this respect. Schlumberger warrants only that its products are free from defects in workmanship and materials and makes no warranty otherwise.

## **Chapter 1 — AREA, VOLUME and CAPACITY**

Area . . . . .	1-1
Annular Area . . . . .	1-3
Volume . . . . .	1-5
Capacity . . . . .	1-7
Displacement of Fluids . . . . .	1-11

## **Chapter 2 — PRESSURE**

Applied Pressure . . . . .	2-1
Hydrostatic Pressure . . . . .	2-1
Differential Pressure . . . . .	2-11

## **Chapter 3 — FORCE**

Force Due To Pressure . . . . .	3-1
Forces Due To Pressure Differentials . . . . .	3-1
String Weight and Buoyancy . . . . .	3-3

## **Chapter 4 — HYDRAULIC FORCES and HOOK-LOADS**

Single Grip Retrievable Packers . . . . .	4-1
Hydraulic Forces and Single Grip Packers . . . . .	4-3
Compression Packers . . . . .	4-11
Hydraulic Forces and Double Grip Packers . . . . .	4-18
Hook-Loads . . . . .	4-18
Tubing O.D. Smaller Than Packer Bore . . . . .	4-19
Tubing O.D. and I.D. Larger than Packer Seal Bore . . . . .	4-22
Tubing O.D. Larger than Packer Seal Bore and Tubing I.D. Smaller Than Packer Seal Bore . . . . .	4-26
General Hook Load Calculations for Unplugged Tubing . . . . .	4-29
Seal Assemblies . . . . .	4-32
Plugged Tubing . . . . .	4-32

General Hook Load Calculations For Plugged Tubing . . . . . 4-37  
 Tapered Tubing Strings . . . . . 4-40

**Chapter 5 — FORCE and LENGTH CHANGES**

Piston Effect . . . . . 5-2  
 Ballooning . . . . . 5-8  
 Buckling . . . . . 5-16  
 Temperature Effects . . . . . 5-22  
 Applied Forces . . . . . 5-28  
 The Total Effect . . . . . 5-34

**Chapter 6 — TUBING STRING**

Tubing Classification . . . . . 6-1  
 Top Joint Tension . . . . . 6-2

**Chapter 7 — TUBING ANCHORS**

Tubing Anchor Calculations for Rod Pump Wells . . . . . 7-1  
 Mechanical Anchors Used in Rod Pumped Wells . . . . . 7-1  
 Tubing Loads and Shear Values . . . . . 7-4

**Appendix A — TUBING DATA**

Tubing Dimensional Data . . . . . A-3  
 Dimensional Data On Selected Heavy Weight  
 and Non-API Tubing . . . . . A-5  
 Tubing Sizes and Capacities . . . . . A-24  
 Tubing Performance Properties . . . . . A-25  
 Performance Data on Selected Heavy Weight  
 and Non-API Tubing . . . . . A-32

## **Appendix B — CASING DATA**

API Casing Dimensional Data . . . . .	B-3
API Casing Sizes and Capacities . . . . .	B-11
API Casing Performance and Properties . . . . .	B-15

## **Appendix C — ANNULAR VOLUMES**

Annular Volume Between One String of Tubing and Casing . . . . .	C-3
Annular Volume Between Two Strings of Tubing and Casing . . . . .	C-41
Annular Volume Between Three Strings of Tubing and Casing . . . . .	C-63

## **Appendix D — FLUID GRADIENTS**

Fluid Gradient Tables . . . . .	D-3
PSI per Barrel Tables, A - Oil . . . . .	D-7
PSI per Barrel Tables B, - Mud Weight . . . . .	D-9
Oil-Water Mixture Gradient Table . . . . .	D-12
Method of Calculating Time in Minutes to Pump Cementing Plug to Seat . . . . .	D-14

## **Appendix E — PRESSURE AND TEMPERATURE**

Tubing Weight Factors $W_s$ , $W_i$ , and $W_o$ . . . . .	E-3
Reverse Ballooning Force . . . . .	E-4
Ballooning Force . . . . .	E-5
Change in Tubing Length due to Change in Average Tubing Temperature . . . . .	E-6
Change in Tubing Force due to Change in Average Tubing Temperature . . . . .	E-7

***Appendix F — TUBING STRETCH***

Slackoff Charts . . . . . F-3  
 Tubing Stretch Charts . . . . . F-11  
 Weight on Packer Charts . . . . . F-22

***Appendix G — TUBING ANCHORS***

Weight of Sucker Rod String in Air . . . . . G-3  
 Tables on Operating Fluid Level Factor,  
 Temperature Increase Factor and  
 Initial Well Fluid Level Factor . . . . . G-4  
 Shear Pin Selection Table . . . . . G-7  
 Pump Plunger Size Table . . . . . G-7

***Appendix H — MISCELLANEOUS***

Decimal Equivalents of Fractions of an Inch in  
 Inches and Millimeters . . . . . H-3  
 Area of Circles . . . . . H-4  
 Conversion Factors . . . . . H-15  
 Temperature Conversion of Fahrenheit to Centigrade . . . . . H-24

***Glossary of Terms***

***Index***

For any oilfield analysis, it is necessary to understand how to calculate areas, volumes and capacities. Fortunately, areas and capacities of tubing and casing are in most field handbooks and in the engineering tables of this book. Most readers of this document will remember how to calculate areas and volumes from grade school, so only a brief review is presented here.

The engineering tables at the back of this book provide all the necessary data to determine well capacities quite easily. The first few sample problems are solved manually to show how the tables were generated. Thereafter, the tables will be used as much as possible to simplify the problem solving. Understanding how the data was generated will make the calculations more meaningful and the tables easier to use. In any case, a clear understanding of the basic principles is necessary before proceeding as subsequent concepts will build on prior ones.

### Area

Most oilfield problems involve circular areas. The area of a circle is proportional to the *square* of its diameter. To calculate the area of a circle use the following formula:

$$A = .785 \times D^2 \quad (1-1)$$

where:

A = area of the circle in square inches

D = diameter of the circle in inches

The constant .785 is derived by dividing the mathematical constant  $\pi$  (called Pi) by 4. A more familiar formula would be:

$$A = \pi \times r^2 \quad (1-2)$$

where:

r = radius of the circle in inches

$\pi = 3.1416$

Since the radius of a circle is the distance from its center to its outside edge, the radius is half the diameter. Incorporating this relationship into equation 1-2, it becomes:

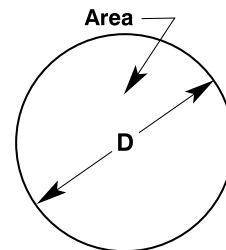

Figure 1.1



# 1

$$A = \pi \times \left(\frac{D}{2}\right)^2 \tag{1-3}$$

By squaring the term inside the brackets (squaring is multiplying a term by itself) the formula now becomes:

$$A = 3.1416 \times \left(\frac{D^2}{4}\right) \tag{1-4}$$

Since the order of division or multiplication is unimportant, pre-dividing  $\pi$  by 4 will simplify equation 1-4 to equation 1-1. Tubing and casing are usually defined by outside diameter and linear weight, making formula 1-1 the most convenient to use.

In the engineering tables, at the back of this manual in Appendix H, is an "Area of Circles" table. The headings along the top represent the whole number portion of a diameter, while the headings along the left represent the decimal fraction portion of a diameter. To find an area of a circle using this chart, move across the top to the whole number of the diameter, then move down that column to the corresponding decimal fraction row and read the area from the intersection.

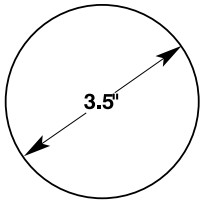

**Problem 1-1**

**Example Problem 1-1:**

What is the area of a circle with a diameter of 3.5 inches?

Solution:

$$\begin{aligned} A &= .785 \times D^2 \\ &= .785 \times (3.5 \text{ in})^2 \\ &= .785 \times 12.25 \text{ in}^2 \\ &= 9.616 \text{ in}^2 \end{aligned}$$

Using the tables in Appendix H, read across the top of the chart to the "3" column. Go down to the row marked "1/2" and read the answer from the intersection. The answer is: 9.6212 in<sup>2</sup>. (The difference in the two answers is due to rounding off the constant .785 to three decimal places. The difference is not significant and will not affect future calculations.)

## Annular Area

The annulus is the space between two circles of different diameter. Most oilfield problems involve determining annular areas such as the cross sectional area of the tubing or finding the annular area between the tubing and casing. In the simplest terms, the annular area between two circles is the difference between the two areas. A general formula for calculating annular areas is:

$$A = .785 \times [D^2 - d^2] \quad (1-5)$$

where:

D = outside diameter in inches

d = inside diameter in inches

Note that it is not the difference in diameters, but the difference in the *squares* of the diameters that matters. Do not subtract the diameters and then calculate the area using equation 1-1. This will not give the correct answer. The formula for the annular area of one tubing string inside a casing is:

$$A = A_{casing\ I.D.} - A_{tubing\ O.D.} \quad (1-6)$$

Substituting in the diameters and simplifying, the formula becomes:

$$A = .785 \times [(Csg.\ I.D.)^2 - (Tbg.\ O.D.)^2] \quad (1-7)$$

For the case of two or more tubing strings inside a casing, the annular area will be the inside area of the casing minus the sum of the outside areas of the tubing strings:

$$A = A_{casing\ I.D.} - (\Sigma A_{tubing_1\ O.D.} + A_{tubing_2\ O.D.} \dots) \quad (1-8)$$

or:

$$A = .785 \times \{(Csg.I.D.)^2 - [(Tbg_1.O.D.)^2 + (Tbg_2.O.D.)^2 + \dots]\} \quad (1-9)$$

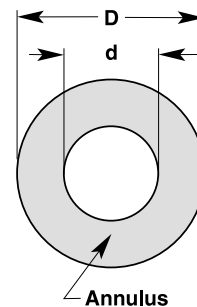

Figure 1.2

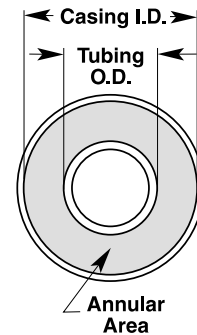

Figure 1.3

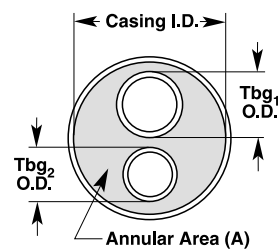
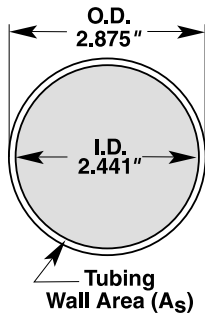

Figure 1.4

# 1



**Problem 1-2**

**Example Problem 1-2:**

What is the tubing wall area of 2<sup>7</sup>/<sub>8</sub>" 6.5 lb/ft tubing?

Solution:

Tubing O.D.: 2.875"

Tubing I.D.: 2.441"

$$\begin{aligned}
 A_s &= .785 \times [(Tbg.O.D.)^2 - (Tbg.I.D.)^2] \\
 &= .785 \times [(2.875 \text{ in})^2 - (2.441 \text{ in})^2] \\
 &= .785 \times [8.266 \text{ in}^2 - 5.958 \text{ in}^2] \\
 &= .785 \times [2.307 \text{ in}^2] \\
 &= 1.811 \text{ in}^2
 \end{aligned}$$

**Example Problem 1-3:**

What is the annular area of two strings of 2<sup>3</sup>/<sub>8</sub>" tubing inside 7" 26 lb/ft casing?

Solution:

Tubing O.D.: 2.375"

Casing I.D.: 6.276"

$$\begin{aligned}
 A &= .785 \times \{(Csg.I.D.)^2 - [(Tbg._1O.D.)^2 + (Tbg._2O.D.)^2]\} \\
 &= .785 \times \{(6.276 \text{ in})^2 - [(2.375 \text{ in})^2 + (2.375 \text{ in})^2]\} \\
 &= .785 \times \{39.388 \text{ in}^2 - [5.641 \text{ in}^2 + 5.641 \text{ in}^2]\} \\
 &= .785 \times \{39.388 \text{ in}^2 - 11.281 \text{ in}^2\} \\
 &= .785 \times \{28.107 \text{ in}^2\} \\
 &= 22.064 \text{ in}^2
 \end{aligned}$$

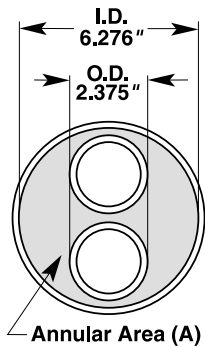

**Problem 1-3**

Fortunately, this information is found in oilfield handbooks and in the engineering tables under "Tubing Dimensional Data" (Appendix A), "Casing Dimensional Data" (Appendix B) and "Annular Volume Between Two Strings of Tubing and Casing" (Appendix C).

# Schlumberger

1

## Volume

Volume is arguably the most important quantity in solving oilfield problems. It is essential to estimating forces on downhole tools, timing arrival of plugs and calculating downhole pressures. In one form or another, all of these concepts rely on being able to calculate the volume of a column of fluid.

Volume is the amount of space something occupies in three dimensions. Calculating volume is a simple matter once the area is known. Multiplying area (space in two dimensions) by height will give volume in three dimensions. The unit types of the two different quantities (area and height) must be the same (i.e. inches, feet, etc.). The units of volume then, will be inches<sup>3</sup>, feet<sup>3</sup>, etc. To avoid confusion, always use compatible units when doing any calculations.

To calculate the volume of a cylinder use the formula:

$$V = \text{Cross Sectional Area} \times \text{Height} \quad (1-10)$$

or

$$V = A \times H = .785 \times D^2 \times H \quad (1-11)$$

where:

V= volume

D = diameter of the cylinder

H = height of the cylinder

A = cross sectional area

### Example Problem 1-4:

What is the volume of a cylindrical tank with an inside diameter of 36 inches and a height of 12 feet?

Solution:

Tank I.D.:           36 inches

Tank Height:       12 feet

To solve this problem the units must be consistent, so the diameter is changed from inches to feet.

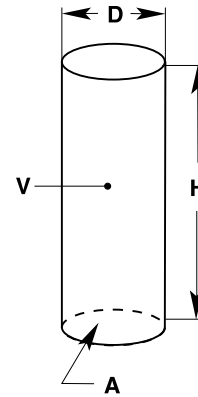
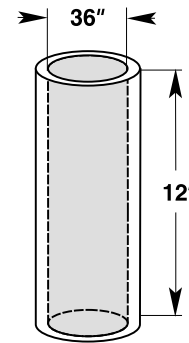
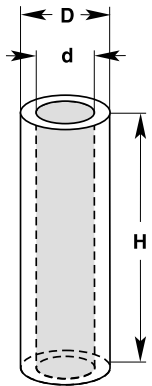

Figure 1.5



Problem 1-4

# 1



**Figure 1.6**

$$36 \text{ in.} \times \frac{1 \text{ ft}}{12 \text{ in.}} = 3 \text{ ft}$$

Now the volume can be determined by:

$$\begin{aligned} V &= .785 \times D^2 \times H \\ &= .785 \times (3 \text{ ft})^2 \times (12 \text{ ft}) \\ &= 84.780 \text{ ft}^3 \end{aligned}$$

Following the logic in determining annular area, annular volume is the difference between a large cylinder and a small cylinder. Annular volume is calculated as:

$$V = (A_{\text{large cylinder}} - A_{\text{small cylinder}}) \times \text{Height} \quad (1-12)$$

or

$$V = .785 \times (D^2 - d^2) \times H$$

where:

V = volume of annular space

D = inside diameter of the large cylinder

d = outside diameter of the small cylinder

H = height of the cylinders

**Example Problem 1-5:**

What is the annular volume between two pipes in a heat exchanger if the large pipe has an inside diameter of 6 inches, the small pipe has an outside diameter of 3 inches and the heat exchanger is six feet long?

Large Pipe I.D.: 6"

Small Pipe O.D.: 3"

Length: 6 ft

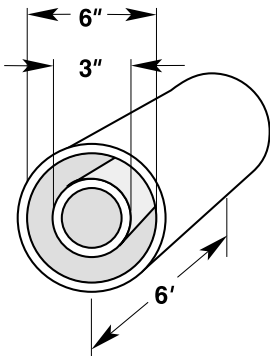

**Problem 1-5**

First, change the diameters from inches to feet.

$$6 \text{ in.} \times \frac{1 \text{ ft}}{12 \text{ in.}} = .5 \text{ ft}$$

$$3 \text{ in.} \times \frac{1 \text{ ft}}{12 \text{ in.}} = .25 \text{ ft}$$

$$\begin{aligned} V &= .785 \times (D^2 - d^2) \times H \\ &= .785 \times [(.5 \text{ ft})^2 - (.25 \text{ ft})^2] \times 6 \text{ ft} \\ &= .883 \text{ ft}^3 \end{aligned}$$

## Capacity

For most service operations it is necessary to know the tubing, drill pipe or casing capacity. To place fluid at the proper depth during well servicing, it is important to know how much fluid to pump. As well, after adding a known amount of fluid to a well, determining the fluid level is possible using the techniques shown here. Determining well capacity is a straight forward application of the previous section.

The units for well capacity are barrels (bbl), gallons (gal) and cubic feet (ft<sup>3</sup>). Since barrels are the most common American unit in the oil industry, most example problems will be in barrels. A list of common conversion factors can be found in Appendix H.

### Tubing, Casing or Drill Pipe Capacity

To determine the capacity of a tubing, casing or drill pipe string, calculate the volume of that part of the well to be filled.

#### Example Problem 1-6:

What is the capacity in barrels of 4,000 ft of 9<sup>5</sup>/<sub>8</sub>" 43.5 lb/ft casing?

Solution:

From "Casing Dimensional Data" in Appendix B:

$$\text{Casing I.D.: } 8.755''$$

Casing I.D. Area:

$$\begin{aligned} A_{\text{casing I.D.}} &= .785 \times (\text{Csg.I.D.})^2 \\ &= .785 \times (8.755)^2 \\ &= 60.170 \text{ in}^2 \end{aligned}$$

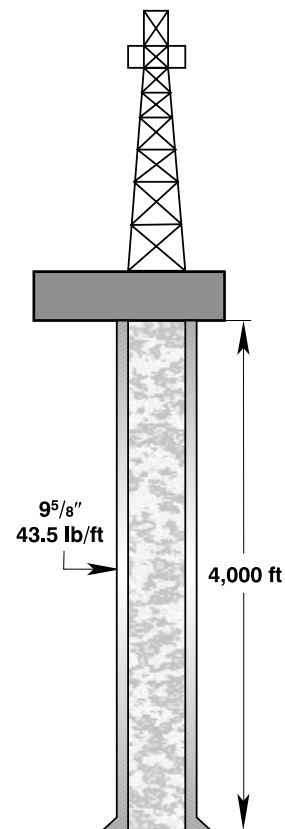

Problem 1-6

# 1

Casing Capacity:

$$\begin{aligned}
 V &= A_{\text{casing I.D.}} \times H \\
 &= 60.170 \text{ in}^2 \times \frac{1 \text{ ft}^2}{144 \text{ in}^2} \times 4,000 \text{ ft} \\
 &= 1671.4 \text{ ft}^3
 \end{aligned}$$

Capacity in Barrels:

$$\begin{aligned}
 V &= 1671.4 \text{ ft}^3 \times .1781 \text{ bbl/ft}^3 \\
 &= 297.7 \text{ bbl}
 \end{aligned}$$

To solve the same problem using the engineering tables, turn to “Casing Sizes and Capacities” in Appendix B. Locate 9<sup>5</sup>/<sub>8</sub>” 43.5 lb/ft casing and move across to the column ‘Barrels per Lineal Foot’. The number .07445 represents the capacity in barrels per foot length of 9<sup>5</sup>/<sub>8</sub>” 43.5 lb/ft casing. To find the casing capacity multiply this number by the height of the casing string.

$$\begin{aligned}
 V &= .07445 \text{ bbl/ft} \times 4,000 \text{ ft} \\
 &= 297.8 \text{ bbl}
 \end{aligned}$$

**Example Problem 1-7:**

What is the annular capacity in barrels between 5,600 ft of 2<sup>3</sup>/<sub>8</sub>” 4.7 lb/ft tubing and 5<sup>1</sup>/<sub>2</sub>” 15.5 lb/ft casing?

Solution:

From “Casing Dimensional Data” in Appendix B:

Casing I.D.: 4.950”

Annular area:

$$\begin{aligned}
 A_{\text{annulus}} &= .785 \times [(Csg.I.D.)^2 - (Tbg.O.D.)^2] \\
 &= .785 \times [(4.950 \text{ in.})^2 - (2.375 \text{ in.})^2] \\
 &= 14.807 \text{ in}^2
 \end{aligned}$$

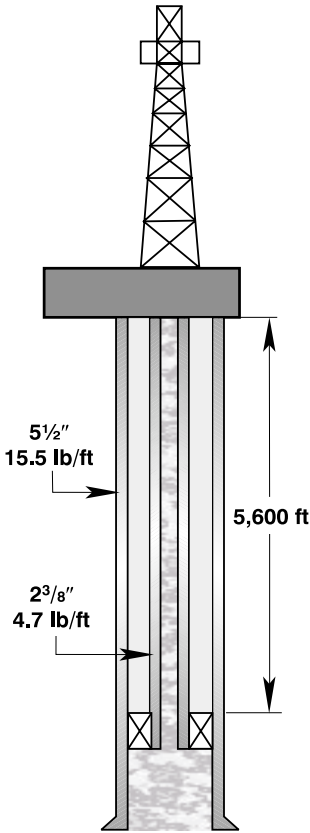

**Problem 1-7**

# Schlumberger

1

Annular Capacity:

$$\begin{aligned} V &= A_{\text{annulus}} \times H \\ &= (14.807 \text{ in}^2) \times \frac{1 \text{ ft}^2}{144 \text{ in}^2} \times 5,600 \text{ ft} \\ &= 575.8 \text{ ft}^3 \end{aligned}$$

Annular Capacity in barrels:

$$\begin{aligned} &= 575.8 \text{ ft}^3 \times .1781 \text{ bbl/ft}^3 \\ &= 102.6 \text{ bbl} \end{aligned}$$

To solve the same problem using the engineering tables, turn to “Annular Volume Between One String of Tubing and Casing” in Appendix C. Locate 5½” 15.5 lb/ft casing and move across to the column ‘Barrels per Lineal Foot’. The number .01832 represents the annular capacity in barrels per foot length of 2¾” O.D. tubing in 5½” 15.5 lb/ft casing. To find the annular capacity multiply this number by the height of the two strings.

$$\begin{aligned} V &= .01832 \text{ bbl/ft} \times 5,600 \text{ ft} \\ &= 102.6 \text{ bbl} \end{aligned}$$

## Fluid Column Heights

Sometimes it is necessary to find the height of a fluid column after a known volume of fluid is added to a well. This is a very similar problem to determining capacity. The following examples illustrate the method of solving this problem.

### Example Problem 1-8:

How high of a fluid column would 24 barrels of water be in 4½” 11.6 lb/ft casing?

Solution:

From “Casing Dimensional Data” in Appendix B:

Casing I.D.: 4.000”

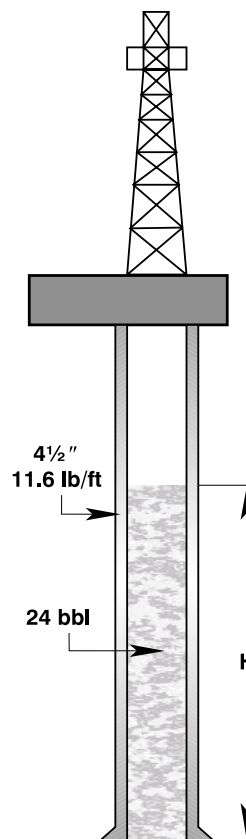

Problem 1-8



## 1

Casing I.D. Area:

$$\begin{aligned}A_{\text{casing I.D.}} &= .785 \times (\text{Csg.I.D.})^2 \\ &= .785 \times (4.000 \text{ in.})^2 \\ &= 12.560 \text{ in}^2\end{aligned}$$

Next, find the capacity of one foot of casing by multiplying the inside area of the casing by one foot. (Remember to keep the units consistent.)

$$\begin{aligned}V_{1ft} &= A_{\text{casing I.D.}} \times 1 \text{ ft} \\ &= (12.560 \text{ in}^2) \times \frac{1 \text{ ft}^2}{144 \text{ in}^2} \times 1 \text{ ft} \\ &= .0872 \text{ ft}^3\end{aligned}$$

Therefore the capacity per foot of casing is .0872 ft<sup>3</sup>/ft. Multiply this by the conversion factor .1781 bbl/ft<sup>3</sup> to obtain the capacity in barrels per foot.

$$\begin{aligned}V_{1ft} &= .0872 \text{ ft}^3/\text{ft} \times .1781 \text{ bbl}/\text{ft}^3 \\ &= .0155 \text{ bbl}/\text{ft}\end{aligned}$$

Divide the volume of fluid added by the capacity per foot to determine the fluid column height.

$$\begin{aligned}H &= \frac{V_{\text{added}}}{V_{1ft}} \\ &= 24 \text{ bbl} \div .0155 \text{ bbl}/\text{ft} \\ &= 1,548.4 \text{ ft}\end{aligned}$$

To solve the same problem using the engineering tables, turn to “Casing Sizes and Capacities” Appendix B. Locate 4½” 11.6 lb/ft casing and move across to the column ‘Lineal Feet per Barrel’. The number 64.340 represents the height in feet of one barrel of fluid in 4½” 11.6 lb/ft casing. To find the column height, multiply this number by the volume of fluid added.

# Schlumberger

1

$$\begin{aligned} H &= H_{1bbl} \times V_{added} \\ &= 64.340 \text{ ft/bbl} \times 24 \text{ bbl} \\ &= 1,544.2 \text{ ft} \end{aligned}$$

Determining the column height of a fluid added to the annulus is exactly the same.

### Example Problem 1-9:

If 30 barrels of water is placed in the annulus between 4½" 11.6 lb/ft casing and 2¾" 4.7 lb/ft tubing, how high is the fluid column?

Solution:

From "Annular Volume Between One String of Tubing and Casing" (Appendix C):

$$H_{1bbl} = 99.372 \text{ ft/bbl}$$

Therefore the fluid column height is:

$$\begin{aligned} H &= H_{1bbl} \times V_{added} \\ &= 99.372 \text{ ft/bbl} \times 30 \text{ bbl} \\ &= 2,981.2 \text{ ft} \end{aligned}$$

## Displacement of Fluids

During many completion and service operations, it is necessary to pump certain fluids (e.g., acid, cement) to a particular location in the well bore. In certain instances, it is also necessary to know when the fluid will reach the desired location. To determine either the location or the time to reach a desired location requires knowing the capacity of each part of the circulating path and the rate at which fluid is pumped.

Determining the capacity of the various circulating paths was covered in the previous section. If a pump truck with a barrel counter is used to measure the displaced fluid, timing the location of the fluid is a simple matter. However, if a rig pump is used, the size and operating speed of the pump will determine the rate at which fluid is circulated. Usually, the rig operator can provide the pump capacity and operating speed. The pump capacity is generally in

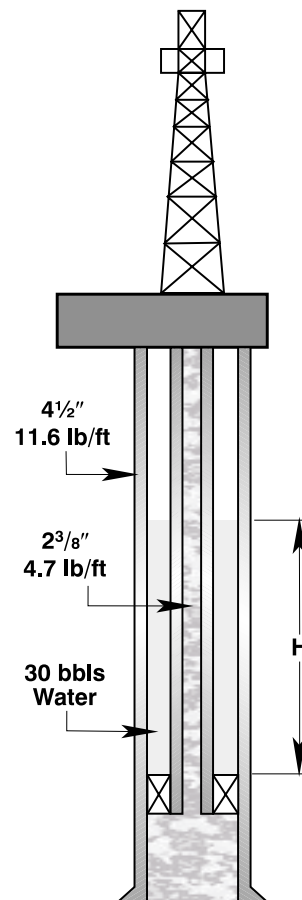

Problem 1-9

# 1

volume per stroke (e.g., bbl/stroke, ft<sup>3</sup>/stroke, etc.) and operating speed in strokes per time (e.g., strokes/min). The flow rate is specified in volume per time (eg., gal/min, ft<sup>3</sup>/min, etc.). To determine the flow rate, multiply the pump capacity by the operating speed:

$$Q = V_{pump} \times f_{pump} \tag{1-13}$$

where:

$Q$  = flow rate (volume/min)

$V_{pump}$  = pump capacity (volume/stroke)

$f_{pump}$  = pump operating speed (strokes/min)

In Appendix H, there is a table conversion factors that will simplify converting pump capacities between units. Special consideration must be given to multiplexing pumps, which have more than one stroke per cycle. This case requires the pump capacity in volume per cycle and the operating speed in cycles per minute. The following example demonstrates all the concepts introduced in this chapter:

**Example Problem 1-10:**

Well Data:

Casing:	7" 23 lb/ft
Tubing:	3½" 9.3 lb/ft
Hanger Depth:	3,000 ft
Liner:	5" 15 lb/ft
Liner Length:	1,200 ft
Landing Collar Height:	100 ft
Open Hole Bore:	6⅛"
Pump Operating Speed:	30 cycles/min.
Pump Efficiency:	85%
Pump Bore:	5"
Pump Stroke:	16"

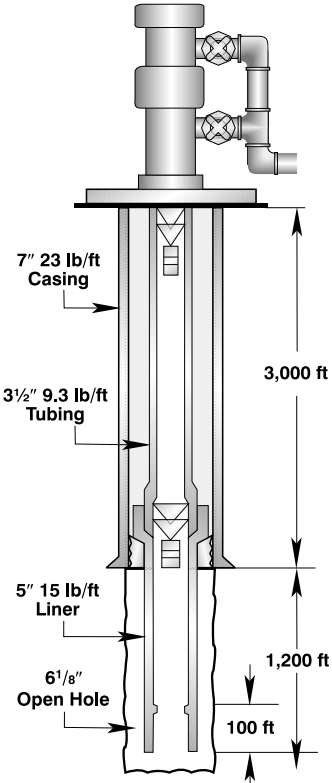

**Problem 1-10**

# Schlumberger

# 1

During a deepening operation, 1,200 feet of 5" 15 lb/ft liner is run into a 6<sup>1</sup>/<sub>8</sub>" diameter open hole. The entire length of liner is to be cemented in place. A Camco Model 'A' Liner Hanger is set at a depth of 3,000 feet in 7" 23 lb/ft casing. Given the above well data, determine the following:

1. The volume of cement (bbl) required to cement the liner in position.
2. The volume of fluid (in bbl) that must be added after the cement to ensure the liner wiper plug latches in the landing collar.
3. The depth of the tubing wiper plug when the first of the cement reaches the liner hanger.
4. If the rig pump is a triplex pump, the time it takes for the tubing wiper plug to latch into the liner wiper plug and the amount of pump strokes it will take.
5. The total time it takes for the liner wiper plug to latch in the landing collar.

The engineering tables will be used when ever possible to simplify the calculations.

Solution:

1. Volume of cement required:

$$\text{Outside Area of Liner (A}_o\text{): } 19.635 \text{ in}^2$$

$$\text{Area of Open Hole (A}_h\text{): } 29.465 \text{ in}^2$$

Annular Area (A<sub>a</sub>):

$$\begin{aligned} A_a &= A_h - A_o \\ &= 29.465 \text{ in}^2 - 19.635 \text{ in}^2 \\ &= 9.830 \text{ in}^2 \end{aligned}$$

Annular Volume (V<sub>a</sub>):

$$\begin{aligned} V_a &= A_a \times H \\ &= 9.830 \text{ in}^2 \times \frac{1 \text{ ft}^2}{144 \text{ in}^2} \times 1,200 \text{ ft} \\ &= 81.917 \text{ ft}^3 \end{aligned}$$

## 1

Volume Below Landing Collar ( $V_L$ ):

Liner Capacity: .1059 ft<sup>3</sup>/ft

$$\begin{aligned}V_L &= .1059 \text{ ft}^3/\text{ft} \times 100 \text{ ft} \\ &= 10.590 \text{ ft}^3\end{aligned}$$

Total Volume of Cement Required ( $V_C$ ):

$$\begin{aligned}V_C &= (10.590 \text{ ft}^3 + 81.917 \text{ ft}^3) \times .1781 \text{ bbl}/\text{ft}^3 \\ &= 16.5 \text{ bbl}\end{aligned}$$

2. Volume of fluid to latch liner wiper plug in landing collar.

This is just the total capacity of the tubing string and the liner down to the landing collar. The landing collar is 100 feet from the bottom of the liner, therefore the total length is 1,100 feet.

Tubing Capacity: .008706 bbl/ft

Liner Capacity: .01887 bbl/ft

$$\begin{aligned}V &= V_T + V_L \\ &= (.008706 \text{ bbl}/\text{ft} \times 3,000 \text{ ft}) + (.01887 \text{ bbl}/\text{ft} \times 1,100 \text{ ft}) \\ &= 26.1 \text{ bbl} + 20.8 \text{ bbl} \\ &= 46.9 \text{ bbl}\end{aligned}$$

3. To determine the depth of the tubing wiper plug when the first of the cement reaches the liner requires finding the height of the cement in 3 1/2" 9.3 lb/ft tubing. From step 1, a total of 16.5 bbl of cement is in the tubing string.

Tubing Capacity: 114.9 ft/bbl

$$\begin{aligned}H &= 16.5 \text{ bbl} \times 114.9 \text{ ft}/\text{bbl} \\ &= 1895 \text{ ft}\end{aligned}$$

Since the liner hanger is set at 3,000 feet, the tubing wiper plug is 1,895 feet above the hanger or 1,105 feet below the surface.

4. Since the pump is a triplex, it has 3 strokes per cycle.

For a pump with a 5" bore and a 16" stroke @ 85% efficiency:

$$\begin{aligned}V_{pump} &= .85 \times .785 \times (\text{bore})^2 \times \text{stroke} \\ &= .85 \times .785 \times (5 \text{ in.})^2 \times (16 \text{ in.}) \\ &= 267 \text{ in}^3/\text{stroke}\end{aligned}$$

$$V_{pump} = .0275 \text{ bbl/stroke}$$

At 3 strokes per cycle and 30 cycles per minute:

$$f_{pump} = 90 \text{ strokes/min}$$

Flow rate @ 85% efficiency (Q):

$$\begin{aligned}Q &= .0275 \text{ bbl/stroke} \times 90 \text{ strokes/min} \\ &= 2.477 \text{ bbl/min}\end{aligned}$$

To determine the amount of time for the tubing wiper plug to latch, divide the total tubing capacity from step 2 by the flow rate.

$$\begin{aligned}t &= 26.1 \text{ bbl} \div 2.447 \text{ bbl/min} \\ &= 10.7 \text{ min} \\ &= 11 \text{ min (to nearest minute)}\end{aligned}$$

Multiply the pump operating speed by the total time to determine the total number of strokes to pump the tubing wiper plug down.

$$\begin{aligned}\# \text{ of strokes} &= 90 \text{ strokes/min} \times 11 \text{ min.} \\ &= 990 \text{ strokes}\end{aligned}$$

5. To determine the total time for the liner wiper plug to latch into the landing collar, divide the total circulating capacity by the flow rate.

$$\begin{aligned}t &= 46.9 \text{ bbl} \div 2.477 \text{ bbl/min} \\ &= 18.9 \text{ min} \\ &= 19 \text{ min (to nearest minute)}\end{aligned}$$



Pressure is defined as the force per unit area exerted on a surface. For example, a force of 10 pounds pushing on a surface with 1 square inch of area would exert a pressure of 10 pounds per square inch on that surface. Mathematically, pressure is expressed as:

$$P = \frac{F}{A} \quad (2-1)$$

where:

P = pressure (lb/in<sup>2</sup>)

F = force (lb)

A = surface area (in<sup>2</sup>)

It is important to remember that pressure exerts in all directions. Figure 2.1 illustrates the concept of pressure. The fluid below the piston exerts a uniform pressure of 10 psi on every surface, perpendicular to the surface planes. When solving oilfield problems, there are two types of pressure to consider: applied and hydrostatic pressure.

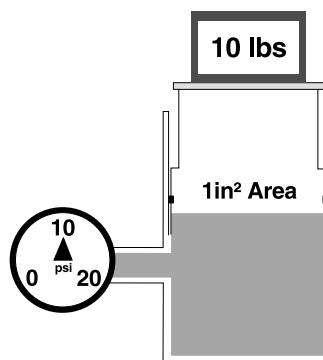

Figure 2.1

### Applied Pressure

Applied pressure is due to a pump or similar means. Applied pressure is felt throughout the system equally. For example, applying 2,000 psi to the inside of a pipe exerts 2,000 psi everywhere on the pipe wall regardless of the pipe size. Applying 5,000 psi at the surface of a 10,000 ft well will exert 5,000 psi throughout the well bore.

### Hydrostatic Pressure

Hydrostatic pressure is fluid pressure due to the weight of fluid above it. Both gases and liquids exert hydrostatic pressure. Hydrostatic pressure is present at all points below the surface of a fluid, but unlike applied pressure it is not constant. The hydrostatic pressure at any point depends on the fluid density and the depth below the fluid surface. A good example of hydrostatic pressure is atmospheric pressure. The weight of the air causes an average pressure of 14.7 psi at sea level. It is well known that as elevation above sea level increases, air pressure decreases.



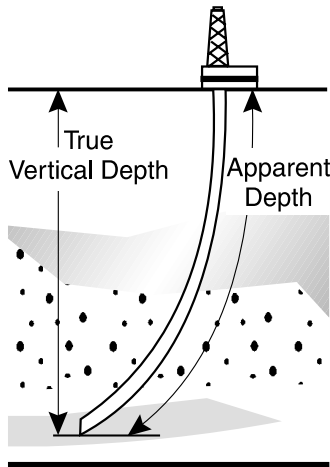

Figure 2.2

Oilfield problems usually involve finding pressures exerted on tubing, casing and downhole tools. In deviated wells (i.e., wells which are not vertical), finding the hydrostatic pressure requires the true vertical depth. For example, the apparent depth of a deviated well may be 10,000 ft, but the vertical depth may only be 7,500 ft. Hydrostatic pressure in a well depends only on true vertical depth.

### Calculating Hydrostatic Pressure

In the previous section, hydrostatic pressure was said to depend on fluid density and depth. Fluid density is defined as *mass* per unit volume. Density is also expressed by specific gravity ( $\gamma$ ). Specific gravity is a comparison to the density of water. For example, a fluid with a specific gravity of 1.5 will have a density 1.5 times that of water. The density of oil is often in API gravity (e.g., 38° API oil). In the American system, it is more common to specify the fluid weight rather than the fluid density since pounds are units of *force*. The units for fluid weight are lb/gal, lb/ft<sup>3</sup> or lb/in<sup>3</sup>. To determine hydrostatic pressure, the following formula may be used:

$$P = w \times h \quad (2-2)$$

where:

P = hydrostatic pressure

w = fluid weight

h = true vertical depth

### Fluid Gradients

Since there are a variety of ways to specify the fluid weight, it is cumbersome to use it when determining hydrostatic pressure. To avoid changing fluid weight and depth into similar units, hydrostatic pressure is usually defined by fluid gradient. Fluid gradient is the pressure exerted per unit depth of a fluid and is derived by manipulating the units. For example, the fluid weight of 38° API oil is 52.06 lb/ft<sup>3</sup>. This can also be expressed as 52.06 lb/ft<sup>2</sup>/ft or lb/ft<sup>2</sup> per ft. The units lb/ft<sup>2</sup> are units of pressure and are changed into lb/in<sup>2</sup> by multiplying by the conversion factor .006944 ft<sup>2</sup>/in<sup>2</sup>. Doing the math gives:

# Schlumberger

$$\begin{aligned} 52.06 \text{ lb/ft}^3 \times .006944 \text{ ft}^2/\text{in}^2 &= .362 \text{ lb/in}^2/\text{ft} \\ &= .362 \text{ psi/ft} \end{aligned}$$

If the fluid weight is in lb/gal, multiplying the fluid weight by .05195 gal/(ft·in<sup>2</sup>) will give the fluid gradient. The engineering tables list fluid gradients in various units to simplify the calculations. Multiplying the fluid gradient by the depth will give the hydrostatic pressure at the specified depth.

$$P = fg \times h \quad (2-3)$$

where:

P = hydrostatic pressure (psi)

fg = fluid gradient (psi/ft)

h = true vertical depth (ft)

## Example Problem 2-1

What is the hydrostatic pressure 1,000 feet below the surface in a well filled with 14 lb/gal mud?

Solution:

Fluid density: 14 lb/gal

Depth: 1,000 ft

Using the "Fluid Gradients" table in Appendix D, the fluid gradient of 14 lb/gal fluid is .728 psi./ft. Therefore the hydrostatic pressure is:

$$\begin{aligned} P &= fg \times h \\ &= .728 \text{ psi/ft} \times 1,000 \text{ ft} \\ &= 728 \text{ psi} \end{aligned}$$

Note that the hydrostatic pressure is not dependent upon the size of the tubing or casing. *Hydrostatic pressure depends only on the fluid density and the depth.* If a well is not completely full, determine the hydrostatic pressure using the true column height of the fluid.

2

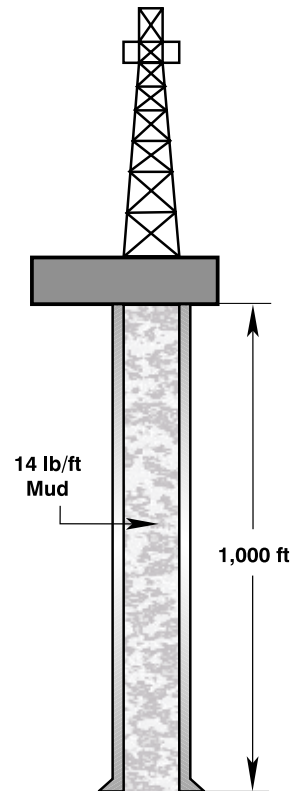

Problem 2-1

2

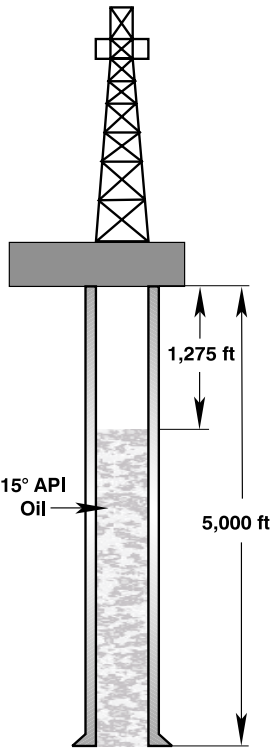

Problem 2-2

### Example Problem 2-2

What is the hydrostatic pressure at the bottom of a 5,000 ft well if the fluid level is at 1,275 ft and the well fluid is 15° API oil?

Solution:

From the “Fluid Gradients” table in Appendix D:

$$fg = .419 \text{ psi/ft}$$

The true vertical height of the fluid column is:

$$\begin{aligned} h &= 5,000 \text{ ft} - 1,275 \text{ ft} \\ &= 3,725 \text{ ft} \end{aligned}$$

Therefore:

$$\begin{aligned} P &= .419 \text{ psi/ft} \times 3,725 \text{ ft} \\ &= 1,561 \text{ psi} \end{aligned}$$

To find the total pressure at any point, add the applied pressure to the hydrostatic pressure.

$$P_{total} = P_{app} + P_{hydro} \tag{2-4}$$

### Example Problem 2-3

Given the following well conditions, determine:

1. The total bottom hole pressure.
2. The total pressure at the surface.
3. The total pressure at 2,500 ft.

Well Depth: 6,400 ft

Fluid: 800 ft of 15 lb/gal cement slurry  
5,600 ft of 9 lb/gal water

Pump Pressure: 1,450 psi

# Schlumberger

Solution:

From the "Fluid Gradients" table in Appendix D:

$$fg_c = .780 \text{ psi/ft}$$

$$fg_w = .468 \text{ psi/ft}$$

## 1. Bottom Hole Pressure

Hydrostatic pressure due to cement slurry:

$$\begin{aligned} P_c &= fg_c \times h_c \\ &= .780 \text{ psi/ft} \times 800 \text{ ft} \\ &= 624 \text{ psi} \end{aligned}$$

Hydrostatic pressure due to water:

$$\begin{aligned} P_w &= fg_w \times h_w \\ &= .468 \text{ psi/ft} \times 5,600 \text{ ft} \\ &= 2,620.8 \text{ psi} \end{aligned}$$

Total hydrostatic pressure:

$$\begin{aligned} P_{hydro} &= P_c + P_w \\ &= 624 \text{ psi} + 2,620.8 \text{ psi} \\ &= 3,244.8 \text{ psi} \end{aligned}$$

Total bottom hole pressure:

$$\begin{aligned} P_{total} &= P_{app} + P_{hydro} \\ &= 1,450 \text{ psi} + 3,244.8 \text{ psi} \\ &= 4,694.8 \text{ psi} \end{aligned}$$

## 2. Total Surface Pressure

Since there is no hydrostatic pressure at the surface, the surface pressure is the applied pressure of 1,450 psi.

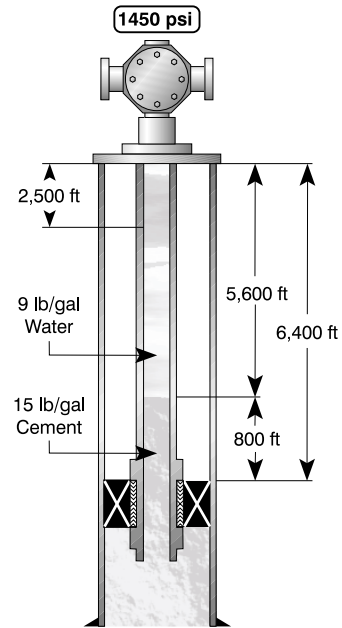

Problem 2-3

### 3. Pressure at 2,500 ft:

At 2,500 ft there is no cement, so only the water is considered.  
Hydrostatic pressure at 2,500 ft:

$$\begin{aligned} P_{hydro} &= fg \times h \\ &= .468 \text{ psi/ft} \times 2,500 \text{ ft} \\ &= 1,170 \text{ psi} \end{aligned}$$

Total pressure at 2,500 ft:

$$\begin{aligned} P_{total} &= P_{app} + P_{hydro} \\ &= 1,450 \text{ psi} + 1,170 \text{ psi} \\ &= 2,620 \text{ psi} \end{aligned}$$

### Fluid Gradients of Mixtures

Sometimes it is necessary to determine the fluid gradient of a mixture of several liquids, such as a mixture of oil and water. To find the fluid gradient of a mixture of two or more liquids, multiply the fluid gradient of each fluid by its percentage of the total, add the results together and divide by 100. Expressing this concept as a mathematical formula:

$$fg_{mix} = \frac{(fg_1 \times f_1) + (fg_2 \times f_2) + (fg_3 \times f_3) + \dots}{100} \quad (2-5)$$

where:

$fg_{mix}$  = fluid gradient of mixture (psi/ft)

$fg_n$  = fluid gradient of liquid  $n$  (psi/ft)

$f_n$  = percentage of liquid  $n$

### Example Problem 2-4

What is the fluid gradient of an oil-water mixture that is 60% water cut, if the water weighs 9.2 lb/gal and the oil is 35° API?

Solution:

From the "Fluid Gradients" table in Appendix D:

$$fg_w = .478 \text{ psi/ft}$$

# Schlumberger

$$fg_o = .366 \text{ psi/ft}$$

Fluid gradient of the mixture:

$$\begin{aligned} fg_{mix} &= \frac{(fg_w \times f_w) + (fg_o \times f_o)}{100} \\ &= \frac{(.478 \text{ psi/ft} \times 60) + (.368 \text{ psi/ft} \times 40)}{100} \\ &= \frac{28.7 + 14.7}{100} \text{ psi/ft} \\ &= .434 \text{ psi/ft} \end{aligned}$$

2

Using the "Fluid Gradients of Oil-Water Mixtures" table in Appendix D:

$$\begin{aligned} fg_{mix} &= \text{water component} + \text{oil component} \\ &= .287 \text{ psi/ft} + .147 \text{ psi/ft} \\ &= .434 \text{ psi/ft} \end{aligned}$$

## Slurry Gradients

In many service operations such as formation fracturing, gravel packing, etc., it is necessary to find a pressure gradient for a fluid-sand mixture. As with mixtures of fluids, adding the weights together does not give the correct results. The sand displaces some of the fluid volume and must be accounted for in the calculations. To determine the weight of a sand slurry use the following formulas:

$$\omega_{slurry} = \frac{\omega_f + (\text{lbs of sand per gal})}{1 + (.0456 \text{ gal/lb}) \times (\text{lbs of sand per gal})} \quad (2-6)$$

where:

$$\omega_{slurry} = \text{weight of sand slurry (lb/gal)}$$

$$\omega_f = \text{weight of fluid (lb/gal)}$$

or:

$$\omega_{slurry} = \frac{\omega_f + (\text{lbs of sand per ft}^3)}{1 + (.0061 \text{ ft}^3/\text{lb}) \times (\text{lbs of sand per ft}^3)} \quad (2-7)$$

## 2

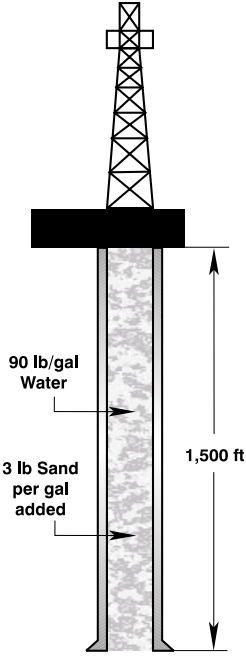

**Problem 2.5**

where:

$$\omega_{slurry} = \text{weight of sand slurry (lb/ft}^3\text{)}$$

$$\omega_f = \text{weight fluid (lb/ft}^3\text{)}$$

**Example Problem 2-5:**

What is the pressure in a 1,500 ft well filled with 9.0 lb/gal water to which 3 pounds of sand per gallon is added?

Solution:

Slurry weight:

$$\begin{aligned} \omega_{slurry} &= \frac{\omega_f + (\text{lbs of sand per gal})}{1 + (.0456 \text{ gal/lb}) \times (\text{lbs of sand per gal})} \\ &= \frac{9.0 \text{ lb/gal} + 3 \text{ lb/gal}}{1 + .0456 \text{ gal/lb} \times 3 \text{ lb/gal}} \\ \omega_{slurry} &= 10.56 \text{ lb/gal} \end{aligned}$$

To determine the slurry pressure gradient, multiply the weight by the conversion factor .05195 gal/(ft·in<sup>2</sup>).

$$\begin{aligned} fg_{slurry} &= 10.56 \text{ lb/gal} \times .05195 \text{ gal/(ft}\cdot\text{in}^2\text{)} \\ &= .548 \text{ psi/ft} \end{aligned}$$

Hydrostatic pressure:

$$\begin{aligned} P &= .548 \text{ psi/ft} \times 1,500 \text{ ft} \\ &= 823 \text{ psi} \end{aligned}$$

**Gas Gradients**

As mentioned earlier, gases also exert hydrostatic pressure. Unlike liquid, gas will compress under pressure and hence its density will increase. In other words, under high pressure more gas will fit into a fixed volume than under low pressure. Since hydrostatic pressure depends on density, gas will exert greater hydrostatic pressure as the applied pressure increases. Temperature also affects the density of a gas. As temperature decreases, gas density increases.

# Schlumberger

As such, gases present a unique problem when present in a well. The bottom hole pressure of a gas column is found as follows:

$$P = P_{sur} \times e^{\left(\frac{.02085 \times G \times h}{T_{avg} + 460^{\circ}\text{F}}\right)} \quad (2-8)$$

where:

P = pressure @ desired depth (psi)

P<sub>sur</sub> = surface pressure (psi)

e = natural logarithm base = 2.71828

G = gas gravity

h = true vertical depth (ft)

T<sub>avg</sub> = average well temperature (°F)

$$= \frac{\text{surface temp} + \text{temp @ depth}}{2} \quad (2-9)$$

Gas gravity is the gravity of the gas compared to air. Some common oilfield gas gravities are:

Air	= 1.000
Carbon Dioxide	= 1.529
Injected Dry Natural Gas	= .650
Methane	= .554
Nitrogen	= .967
Produced Natural Gas	= .850
Propane	= 1.554

Formulas 2-8 and 2-9 apply to gases only. Some gases such as CO<sub>2</sub> are normally a liquid under high pressure and must be treated as such for determining hydrostatic pressure.

2



2

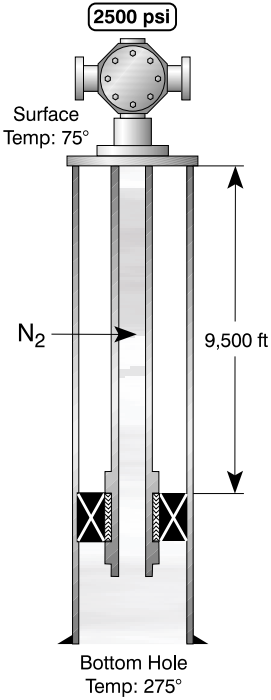

**Problem 2-6**

**Example Problem 2-6:**

Determine the bottom hole pressure of a well under the following conditions:

Well Data:

- Depth: 9,500 ft
- Bottom Hole Temp.: 275°F
- Surface Temperature: 75°F
- Surface Pressure: 2,500 psi
- $G_{N_2} = .967$

Solution:

Average well temperature:

$$T_{avg} = \frac{\text{surface temp} + \text{temp @ depth}}{2}$$

$$= \frac{75^\circ\text{F} + 275^\circ\text{F}}{2}$$

$$= 175^\circ\text{F}$$

Bottom hole pressure:

$$P = P_{sur} \times e^{\left(\frac{.02085 \times G \times h}{T_{avg} + 460^\circ\text{F}}\right)}$$

$$= 2,500 \text{ psi} \times e^{\left(\frac{.02085 \times .967 \times 9,500 \text{ ft}}{175 + 460^\circ\text{F}}\right)}$$

$$= 2,500 \text{ psi} \times 1.352$$

$$= 3,380 \text{ psi}$$

## Differential Pressure

Differential pressure is the pressure across a tool, tubing wall, etc. Figure 2.3 illustrates the concept of differential pressure. If the pressure in the annulus is 500 psi and the pressure in the tubing string is 200 psi, there is a pressure differential across the tool and across the tubing wall. The magnitude of the differential pressure is the difference between the two pressures, namely 300 psi. Differential pressure in equation form is:

$$P_{diff} = P_a - P_b \quad (2-10)$$

where:

$P_{diff}$  = differential pressure

$P_a$  = pressure @ point a

$P_b$  = pressure @ point b

It is very important to state which way a differential pressure is acting to avoid confusion. In the example of Figure 2.3, the differential pressure is written as 300 psi - annulus. Later chapters will discuss in detail the importance of differential pressures across tools and other equipment. For now, it is enough to know that differential pressures should not exceed the pressure rating of the equipment.

Although most modern service tools have a built in equalizing system, sometimes it is necessary to balance the differential pressure across a tool before unsetting it. To balance a pressure differential, pressure is applied to the low pressure side, equal to the differential pressure.

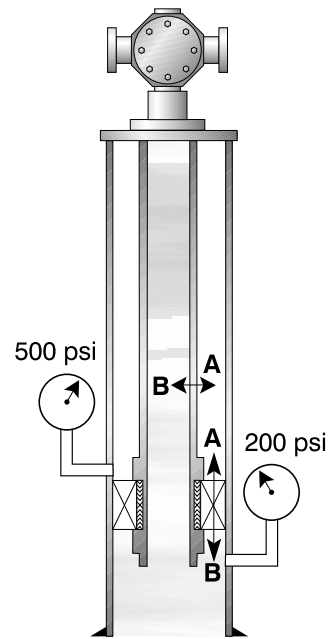

Differential Across Tubing  
Differential Across Packer

Figure 2.3

2

2

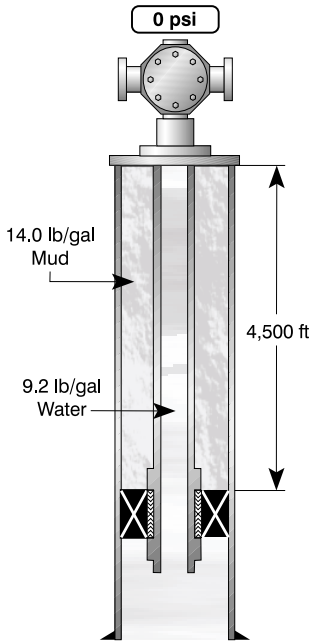

Problem 2-7

**Example Problem 2-7:**

What is the differential pressure across a packer at 4,500 ft in a well with the annulus full of 14.0 lb/gal mud and the tubing full of 9.2 lb/gal water? If the packer has no built in equalizing system, where must the pressure be applied to release it?

Solution:

From the "Fluid Gradients" table in Appendix D:

$$\text{Annulus Gradient} = .728 \text{ psi/ft}$$

$$\text{Tubing Gradient} = .478 \text{ psi/ft}$$

Annulus Pressure ( $P_o$ )<sup>1</sup>:

$$\begin{aligned} P_o &= fg_o \times h \\ &= .728 \text{ psi/ft} \times 4,500 \text{ ft} \\ &= 3,276 \text{ psi} \end{aligned}$$

Tubing Pressure ( $P_i$ )<sup>1</sup>:

$$\begin{aligned} P_i &= fg_i \times h \\ &= .478 \text{ psi/ft} \times 4,500 \text{ ft} \\ &= 2,151 \text{ psi} \end{aligned}$$

Differential Pressure ( $P_{diff}$ ):

$$\begin{aligned} P_{diff} &= P_o - P_i \\ &= 3,276 \text{ psi} - 2,151 \text{ psi} \\ &= 1,125 \text{ psi} - \text{annulus} \end{aligned}$$

To balance the differential pressure, 1,125 psi must be applied to the tubing.

**Example Problem 2-8**

A Camco Model 'Hydro-6' Retrievable Packer is run into a low fluid well. The 'Hydro-6' packer requires a differential pressure of 3,000 psi to set. Given the well conditions below, determine the following:

# Schlumberger

1. The pressure that must be applied at the surface to set the packer if the well fluid is encountered at 3,500 ft?
2. If the fluid level is 7,000 ft instead of 3,500 ft, how much fluid must be added to set the packer?

Well Data:

Tubing:	27/8" 6.5 lb/ft EUE
Packer Depth:	8,000 ft
Well Fluid:	9.8 lb/gal salt water
Setting Pressure:	3,000 psi

Solution:

1. Applied Pressure ( $P_{app}$ ):

From the "Fluid Gradients" Table in Appendix D:

$$fg = .509 \text{ psi/ft}$$

$$h = 3,500 \text{ ft}$$

Since there is no differential pressure initially, the added fluid creates a pressure differential due to its hydrostatic pressure.

Hydrostatic pressure due to filling the tubing ( $P_h$ ):

$$\begin{aligned} P_h &= fg \times h \\ &= .509 \text{ psi/ft} \times 3,500 \text{ ft} \\ &= 1,782 \text{ psi} \end{aligned}$$

By filling the tubing, 1,782 psi of excess hydrostatic pressure is applied to the packer. The 'Hydro-6' requires 3,000 psi differential pressure to set, therefore:

$$\begin{aligned} P_i &= P_{app} + P_h \\ P_{app} &= P_i - P_h \\ &= 3,000 \text{ psi} - 1,782 \text{ psi} \\ &= 1,218 \text{ psi} \end{aligned}$$

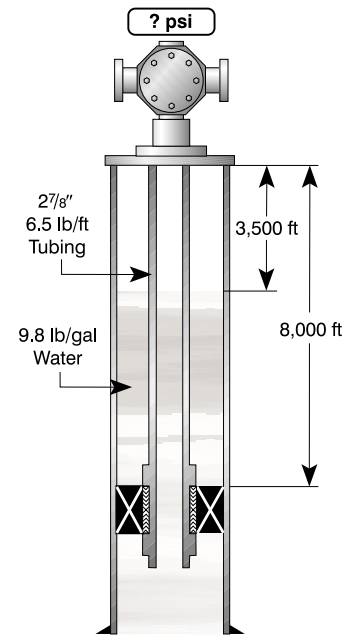

Problem 2-8(1)

2

**2**

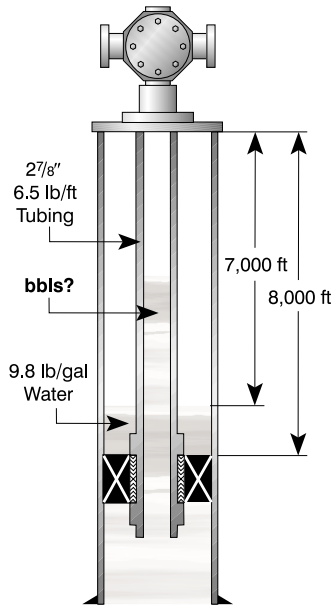

**Problem 2-8(2)**

A pressure of 1,218 psi is required to set the packer.

- Fluid Level at 7,000 ft.  
Hydrostatic pressure due to filling the tubing ( $P_h$ ):

$$\begin{aligned}
 P_h &= fg \times h \\
 &= .509 \text{ psi/ft} \times 7,000 \text{ ft} \\
 &= 3,563 \text{ psi}
 \end{aligned}$$

By filling the tubing, excess pressure is placed on the packer. From the "PSI per Barrel" table in Appendix D, 9.8 lb/gal fluid in 27/8" 6.5 lb/ft EUE tubing exerts a hydrostatic pressure of 87.9 psi per barrel of fluid. Dividing the required setting pressure by this figure will give the proper amount of fluid to add to the tubing.

$$\begin{aligned}
 V &= \frac{P_{\text{set}}}{\text{psi per barrel}} \\
 &= 3,000 \text{ psi} \div 87.9 \text{ psi/bbl} \\
 &= 34.1 \text{ bbl}
 \end{aligned}$$

The "PSI per Barrel" in Appendix D, lists the hydrostatic pressure per barrel of various fluids in several types of tubing and drill pipe. This table is very useful during certain completion operations where the differential pressure is unknown, but the volume of fluid is known. Example Problem 2-9 is such a case.

### Example Problem 2-9

A well that has just been cement squeezed, has the following final conditions:

- Casing: 5 1/2" 23 lb/ft
- Tubing: 2 7/8" 6.5 lb/ft EUE
- Cement: 2 bbl, 15.5 lb/gal
- Mud: 12 lb/gal
- Water Pad: 5 bbl, 8.34 lb/gal

# Schlumberger

Determine where to apply pressure (i.e., tubing or annulus) and how much to unset the tool?

Solution:

In this situation, the tool must be unset and the excess cement backwashed out of the tubing before it sets. The same weight of mud is in the annulus and the tubing, so there is no differential pressure above the water pad and everything above it is ignored. Since time is short and determining the pressure differential using previous techniques takes time, finding the differential pressure per barrel between the cement and mud and the water and mud is done before the job.

From the "PSI per Barrel" table:

$$\begin{aligned} &15.5 \text{ lb/gal cement in } 2\frac{7}{8}'' \text{ 6.5 lb/ft tubing} \\ &= 139.0 \text{ psi/bbl} \end{aligned}$$

$$\begin{aligned} &12.0 \text{ lb/gal mud in } 2\frac{7}{8}'' \text{ 6.5 lb/ft tubing} \\ &= 107.6 \text{ psi/bbl} \end{aligned}$$

$$\begin{aligned} &8.34 \text{ lb/gal water in } 2\frac{7}{8}'' \text{ 6.5 lb/ft tubing} \\ &= 74.8 \text{ psi/bbl} \end{aligned}$$

Differential pressure per barrel between water and mud:

$$\begin{aligned} &= 107.6 \text{ psi/bbl} - 74.8 \text{ psi/bbl} \\ &= 32.8 \text{ psi/bbl} - \text{annulus} \end{aligned}$$

Differential pressure per barrel between cement and mud:

$$\begin{aligned} &= 139.0 \text{ psi/bbl} - 107.6 \text{ psi/bbl} \\ &= 31.4 \text{ psi/bbl} - \text{tubing} \end{aligned}$$

The final conditions are shown in the illustration, so the differential pressure is found as follows:

Water:

$$\begin{aligned} P_o &= 32.8 \text{ psi/bbl} \times 5 \text{ bbl} \\ &= 164 \text{ psi} - \text{annulus} \end{aligned}$$

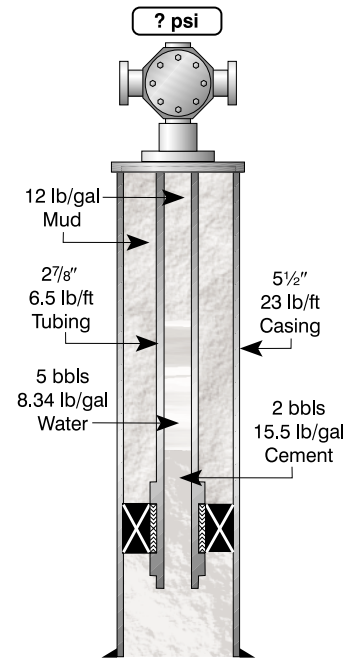

Problem 2-9.

2

Cement:

$$\begin{aligned} P_i &= 31.4 \text{ psi/bbl} \times 2 \text{ bbl} \\ &= 63 \text{ psi} - \text{tubing} \end{aligned}$$

Total differential pressure @ tool:

$$\begin{aligned} P_{dif} &= P_o - P_i \\ &= 164 \text{ psi} - 63 \text{ psi} \\ &= 101 \text{ psi} - \text{annulus} \end{aligned}$$

In this case there is only 101 psi differential to be considered. In some cases the differential pressure will be much higher.

---

<sup>1</sup> The symbols  $P_o$  and  $P_i$  will denote annulus pressure and tubing pressure respectively throughout this book.

### Force Due To Pressure

Force is the amount of push or pull on an object, measured in pounds force. Pressure acting on an area will produce a force on that area. In Chapter 2, pressure was defined as force per unit area. Therefore, force is dependent on pressure and area. Rearranging equation 2-1, force due to pressure is:

$$F = P \times A \quad (3-1)$$

where:

F = force (lbs)

P = pressure (psi)

A = Area (in<sup>2</sup>)

Small pressures can create very large forces. Figure 3.1 shows a simple piston arrangement. The 10 lb weight acting on the 1 in<sup>2</sup> area piston generates 10 psi of pressure in the oil. Use equation 3-1 to determine the weight which the large piston can support.

$$\begin{aligned} F &= P \times A \\ &= 10 \text{ psi} \times 10 \text{ in}^2 \\ &= 100 \text{ lbs} \end{aligned}$$

The 10 lb weight on the 1 in<sup>2</sup> piston generates enough force to lift 100 lbs with the 10 in<sup>2</sup> piston. 10 psi is only a little less than atmospheric pressure of 14.7 psi. The much higher pressures associated with oil wells can have catastrophic effects on downhole equipment if not planned for in advance.

### Forces Due To Pressure Differentials

A differential pressure acting across a piece of equipment will also generate a net force. The net force on a piece of equipment is equal to the individual pressures multiplied by the areas they act on. Multiplying the differential pressure by the area will not give the correct result unless both areas are equal (this is very rare). In Chapter 2, force was described as a *vector* quantity, meaning it has direction and magnitude. The net force is the *vector sum* of

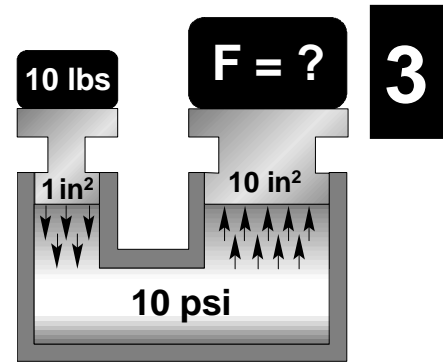

Force & Pressure

Figure 3.1



## 3

the individual forces acting on the object. A vector sum means that only forces acting along the same line are added or subtracted.

When dealing with differential pressures, it is important to keep track of which direction the force will act. In an oil well, most of the forces will act up or down. Because a downward acting force will show up as positive on a weight indicator, they are assigned a positive value. Upward forces are considered negative. This is the sign convention used throughout this book. Regardless of what directions are positive or negative, the sign convention must be consistent for a given problem. It is a very good idea to draw arrows beside the force value to represent the direction in which each force acts.

**Example Problem 3-1:**

In the hydraulic jack, shown in the illustration, a pump is capable of producing a pressure of 50 psi on the bottom of the piston. The pressure on the top of the piston is constant at 75 psi. What is the maximum capacity of the jack? What is the differential pressure across the piston?

Solution:

First, determine the force on the top of the piston.

$$\begin{aligned}
 F_{\text{top}} &= P_{\text{top}} \times A_{\text{top}} \\
 &= 75 \text{ psi} \times (6 \text{ in}^2 - 5 \text{ in}^2) \\
 &= 75 \text{ lbs } \downarrow
 \end{aligned}$$

Now find the force on the underside of the piston.

$$\begin{aligned}
 F_{\text{bot}} &= P_{\text{bot}} \times A_{\text{bot}} \\
 &= 50 \text{ psi} \times 6 \text{ in}^2 \\
 &= 300 \text{ lbs } \uparrow
 \end{aligned}$$

The net force on the piston is the capacity of the jack.

$$\begin{aligned}
 F_{\text{net}} &= F_{\text{bot}} - F_{\text{top}} \\
 &= 300 \text{ lbs } \uparrow - 75 \text{ lbs } \downarrow \\
 &= 225 \text{ lbs } \uparrow
 \end{aligned}$$

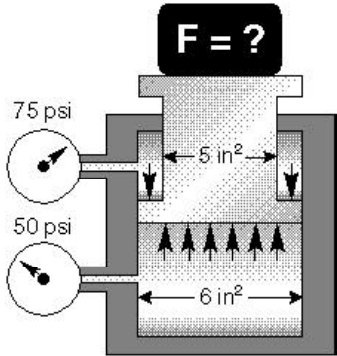

**Problem 3-1**

The differential pressure across the piston is:

$$\begin{aligned} P_{\text{diff}} &= P_{\text{top}} - P_{\text{bot}} \\ &= 75 \text{ psi} - 50 \text{ psi} \\ &= 25 \text{ psi (top to bottom)} \end{aligned}$$

Even though the pressure above the piston was greater than that below, the jack can still lift a 225 lb weight, due to the difference in areas.

## String Weight and Buoyancy

### 1. String Weight in Air

Tubing and casing are specified by outside diameter and linear weight per foot. For a particular size of pipe, the string weight in air is the linear weight per foot times the total length.

$$W_{\text{air}} = \omega \times L \quad (3-2)$$

where:

$W_{\text{air}}$  = string weight in air (lbs)

$\omega$  = linear weight per foot of string (lbs/ft)

$L$  = total string length (ft)

Some well completions have a tapered tubing or casing string. A good example is a well with a casing liner at the bottom. The total string weight is the sum of all the individual string weights. In equation form this is:

$$W_{\text{air}} = (\omega_1 \times L_1) + (\omega_2 \times L_2) + \dots \quad (3-3)$$

where:

$W_{\text{air}}$  = string weight in air (lbs)

$\omega_n$  = linear weight per foot of string  $n$  (lbs/ft)

$L_n$  = total length of string  $n$  (ft)

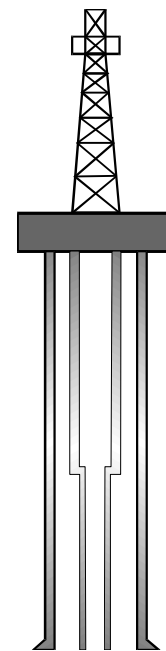

**Tapered String**

**Figure 3.2**

**3**

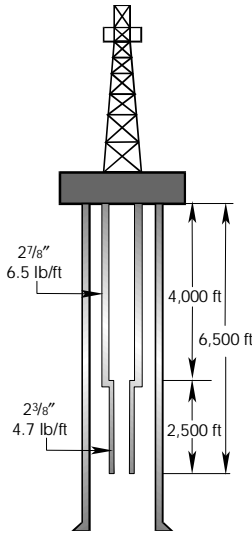

**Problem 3-2**

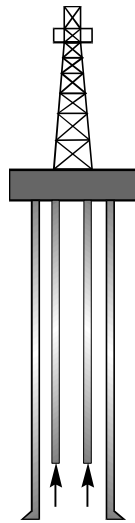

**String Weight in Fluid**

**Figure 3.3**

**Example Problem 3-2:**

What is the weight in air of a 6,500 foot long tubing string consisting of 4,000 feet of 2 7/8" 6.5 lb/ft tubing and the remaining 2,500 feet is 2 3/8" 4.7 lb/ft tubing?

Solution:

$$\begin{aligned}
 W_{\text{air}} &= (\omega_1 \times L_1) + (\omega_2 \times L_2) \\
 &= (6.5 \text{ lb/ft} \times 4,000 \text{ ft}) + (4.7 \text{ lb/ft} \times 2,500 \text{ ft}) \\
 &= 26,000 \text{ lbs} + 11,750 \text{ lbs} \\
 &= 37,750 \text{ lbs}
 \end{aligned}$$

**2. String Weight in Fluid**

The weight of a tubing or casing string immersed in a fluid is less than its weight in air due to forces the fluid exerts on the string. Pressure at the bottom of the string will act on the cross-sectional area of the string and produce an upward force. This upward force is known as buoyancy. The buoyancy force is equal to the total pressure at the bottom of the string times the cross-sectional area of the string. The weight indicator reading is the string weight in air, less the buoyancy forces on the string.

**a) Non-tapered Strings**

$$W_{\text{fluid}} = (\omega \times L) - P \times A_s \tag{3-4}$$

where:

- $W_{\text{fluid}}$  = string weight in fluid (lbs)
- $\omega$  = linear weight per foot of string (lbs/ft)
- $L$  = total string length (ft)
- $P$  = total pressure at depth (psi)
- $A_s$  = cross sectional area of string (in<sup>2</sup>)

# Schlumberger

## Example Problem 3-3:

What is the weight of 8,400 ft of 7" 26 lb/ft casing immersed in 12.6 lb/gal mud?

Solution:

From "Casing Dimensional Data" in Appendix B, for 7" 26 lb/ft casing:

$$A_s = 7.549 \text{ in}^2$$

From the "Fluid Gradients" table in Appendix D, for 12.6 lb/gal mud:

$$fg = .655 \text{ psi/ft}$$

1. Hydrostatic pressure at 8,400 ft:

$$\begin{aligned} P &= fg \times h \\ &= .655 \text{ psi/ft} \times 8,400 \text{ ft} \\ &= 5502 \text{ psi} \end{aligned}$$

2. String weight in mud:

$$\begin{aligned} W_{\text{mud}} &= (\omega \times L) - P \times A_s \\ &= (26 \text{ lb/ft} \times 8,400 \text{ ft}) - (5502 \text{ psi} \times 7.549 \text{ in}^2) \\ &= 218,400 \text{ lbs} - 41,535 \text{ lbs} \\ &= 176,865 \text{ lbs} \end{aligned}$$

If a tubing string is sealed with a packer, the fluid pressure below the packer exerts the buoyancy force. For the case shown in Figure 3.4, the weight of the tubing string is the string weight in air, minus the tubing pressure at the packer depth, times the tubing wall cross-sectional area.

## Example Problem 3-4:

What is the weight of 5,000 ft of 3<sup>1</sup>/<sub>2</sub>" 9.30 lb/ft tubing if the tubing is filled with 13 lb/gal acid and the annulus is filled with 9.3 lb/gal salt water?

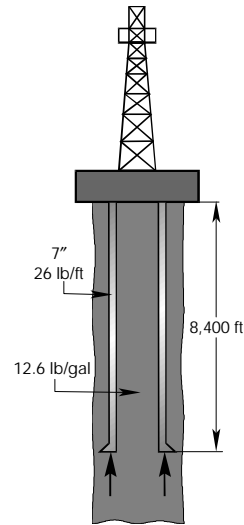

Problem 3-3

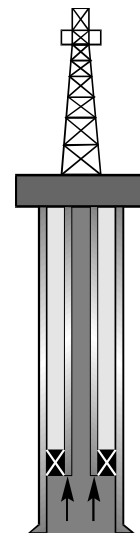
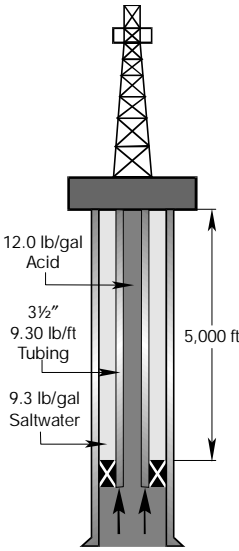

Figure 3.4

3

**3**



**Problem 3-4**

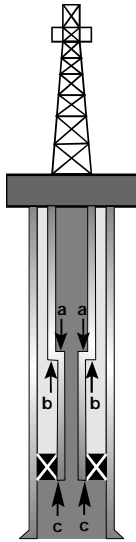

**Tapered String In Fluid**

**Figure 3.6**

**Solution:**

From "Tubing Dimensional Data" in Appendix A, for 3 1/2" 9.30 lb/ft tubing:

$$A_s = 2.590 \text{ in}^2$$

From the "Fluid Gradients" table in Appendix D, for 13 lb/gal acid:

$$fg = .675 \text{ psi/ft}$$

1. Hydrostatic pressure at 5,000 ft ( $P_i$ ):

$$\begin{aligned} P_i &= fg \times h \\ &= .675 \text{ psi/ft} \times 5,000 \text{ ft} \\ &= 3,375 \text{ psi} \end{aligned}$$

2. String weight:

$$\begin{aligned} W &= (\omega \times L) - P \times A_s \\ &= (9.30 \text{ lb/ft} \times 5,000 \text{ ft}) - (3,375 \text{ psi} \times 2.590 \text{ in}^2) \\ &= 46,500 \text{ lbs} - 8,471 \text{ lbs} \\ &= 38,029 \text{ lbs} \end{aligned}$$

**b) Tapered Strings**

When considering a tapered string, the same general principles apply; that is the weight in fluid of a tapered string is the weight in air minus the buoyancy forces. However, different fluids in the tubing and annulus cause forces at the tapers which alter the weight indicator reading as follows (refer to Figure 3.6):

Force 'a', equal to the total tubing pressure at the taper times the difference between the inside areas.

Force 'b', equal to the total annulus pressure at the taper times the difference between the outside areas.

Force 'c' acting upward, equal to the tubing pressure at the packer times the cross-sectional area of the lower tubing string. For the case shown in Figure 3.6, the force 'a' acts downward to

# Schlumberger

increase the weight indicator reading. Force 'b' acts upward and decreases the weight indicator reading. You may come across situations where the opposite is true. Anytime there is a difference in I.D. or O.D., there is a force either up or down. Analyze each ledge individually and combine the results for the total effect.

Expressing the concept as a formula:

$$W_{\text{fluid}} = W_{\text{air}} + \Sigma F_B \quad (3-5)$$

where

$$W_{\text{fluid}} = \text{string weight in fluid (lbs)}$$

$$W_{\text{air}} = \text{string weight in air (lbs)}$$

$$\Sigma F_B = \text{sum of all buoyancy forces (lbs)}$$

The buoyancy forces are added to the string weight because they usually act upwards and by definition are negative. (Adding a negative number is the same as subtracting a positive one.) Example problem 3-5 illustrates the concept.

### Example Problem 3-5:

What would be the weight of the tubing string in Example Problem 3-2 if the tubing is full of 30° API oil and the annulus is filled with 9.0 lb/gal brine?

Solution:

Tbg. Fluid Gradient:	.379 psi/ft
Csg. Fluid Gradient:	.467 psi/ft
Top Tubing $A_i$ :	4.680 in <sup>2</sup>
Top Tubing $A_o$ :	6.492 in <sup>2</sup>
Bottom Tubing $A_i$ :	3.126 in <sup>2</sup>
Bottom Tubing $A_o$ :	4.430 in <sup>2</sup>
Bottom Tubing $A_s$ :	1.304 in <sup>2</sup>
$W_{\text{air}}$ :	37,750 lbs (from problem 3-2)

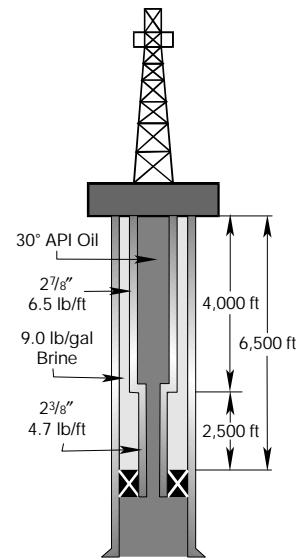

Problem 3-5.

1. Tubing pressure at taper [(P)<sub>t</sub>]:

$$\begin{aligned}(P)_t &= fg_t \times h_t \\ &= .379 \text{ psi/ft} \times 4,000 \text{ ft} \\ &= 1,516 \text{ psi}\end{aligned}$$

2. Tubing pressure at packer [(P)<sub>p</sub>]:

$$\begin{aligned}(P)_p &= fg_t \times h_p \\ &= .379 \text{ psi/ft} \times 6,500 \text{ ft} \\ &= 2,464 \text{ psi}\end{aligned}$$

3. Annulus Pressure at taper [(P)<sub>o</sub>]:

$$\begin{aligned}(P)_o &= fg_o \times h_t \\ &= .467 \text{ psi/ft} \times 4,000 \text{ ft} \\ &= 1,868 \text{ psi}\end{aligned}$$

4. Sum of buoyancy forces ( $\Sigma F_B$ ):

Force 'a' (F<sub>a</sub>) ↓:

$$\begin{aligned}F_a &= (P)_t \times [(A)_1 - (A)_2] \\ &= 1,516 \text{ psi} \times [4.680 \text{ in}^2 - 3.126 \text{ in}^2] \\ &= 2,356 \text{ lbs} \downarrow\end{aligned}$$

Force 'b' (F<sub>b</sub>) ↑:

$$\begin{aligned}F_b &= (P)_o \times [(A)_1 - (A)_2] \\ &= 1,868 \text{ psi} \times [6.492 \text{ in}^2 - 4.430 \text{ in}^2] \\ &= 3,852 \text{ lbs} \uparrow\end{aligned}$$

# Schlumberger

Force 'c' ( $F_c$ ) ↑:

$$\begin{aligned} F_c &= (P_i)_p \times (A_s)_2 \\ &= 2,464 \text{ psi} \times 1.304 \text{ in}^2 \\ &= 3,213 \text{ lbs} \uparrow \end{aligned}$$

Total buoyancy forces ( $\Sigma F_B$ ):

$$\begin{aligned} \Sigma F_B &= F_a + F_b + F_c \\ &= 2,356 \text{ lbs} \downarrow + 3,852 \text{ lbs} \uparrow + 3,213 \text{ lbs} \uparrow \end{aligned}$$

Using the convention that positive forces act downward and negative forces act upward:

$$\begin{aligned} \Sigma F_B &= 2,356 \text{ lbs} + (-3,852 \text{ lbs}) + (-3,213 \text{ lbs}) \\ &= 2,356 \text{ lbs} - 3,852 \text{ lbs} - 3,213 \text{ lbs} \\ &= -4,709 \text{ lbs or } 4,709 \text{ lbs} \uparrow \end{aligned}$$

5. String weight ( $W$ ):

$$\begin{aligned} W &= W_{\text{air}} + \Sigma F_B \\ &= 37,750 \text{ lbs} \downarrow + 4,709 \text{ lbs} \uparrow \\ &= 37,750 \text{ lbs} + (-4,709 \text{ lbs}) \\ &= 37,750 \text{ lbs} - 4,709 \text{ lbs} \\ &= 33,041 \text{ lbs or } 33,041 \text{ lbs} \downarrow \end{aligned}$$

3



**Schlumberger**

**3**

There are many different types of packers, each with its own considerations regarding forces. This chapter discusses, in general terms, the more common types of retrievable packers and how tubing and hydraulic forces affect them.

Tubing run packers are generally classified into two categories:

- Single Grip Retrievable Packers**
- Double Grip Retrievable Packers**

### **Single Grip Retrievable Packers**

Single grip retrievable packers are the simplest and most economical retrievable packers. These packers have one set of slips that anchor the packer to the casing and hold the packer from moving in one direction only. Single grip retrievable packers are further classified into three basic types:

- Non-Equalizing Tension Packer
- Non-Equalizing Compression Packer
- Equalizing Compression Packer

#### **Non-Equalizing Tension Packer**

The Model 'SA-3' retrievable packer is a typical example of a non-equalizing tension packer. The packer is set and packed off with tension pulled into it with the tubing string. It remains packed off so long as a tensile force is on the packer. Any force due to temperature or pressure which places compression on the packer will adversely affect the packer. As the name implies, this type of packer has no provision for equalizing differential pressure when releasing it. These packers usually incorporate a secondary shear release system activated by tubing tension.

#### **Non-Equalizing Compression Packers**

A typical compression packer of this type is the Model 'CA-3'. The packer is set and packed off with tubing weight. A compression packer remains packed off as long as suitable compression is on the packer. Any force that works against this compression will tend to unset the packer. There is no provision for equalizing differential pressure across the tool.

## **Equalizing Compression Packers**

The Model 'SR-2' retrievable packer is a single grip compression set packer with a pressure equalizing system. The packer operates in the same manner as other compression packers and the same general principles apply. The equalizing provision allows any pressure differential across the packer to bleed off when releasing the packer. This provision is very important in deep wells where pressure differentials may be sufficient to prevent a non-equalizing packer from releasing.

## **Double Grip Retrievable Packers**

Double grip retrievable packers have bi-directional slips that, once the packer is set, prevent the packer from moving in either direction in the presence of tubing and/or hydraulic forces. Most (but not all) double grip packers incorporate some form of pressure equalizing system. There are a great many models of retrievable packers from a variety of manufacturers, but most can be classified as one of the following types:

### **Compression Packer with Hydraulic Hold-Downs**

These packers are set with tubing weight slacked off onto the packer. A set of hydraulically actuated slips prevent the packer from moving up the well in the presence of high pressure below the packer. The Model 'SR-1' and 'Omegamatic Service Packer' are examples of this type of packer. The hold-down systems of these packers also include an unloader piston which pushes down on the packer mandrel to help keep the valve closed. The unloader piston and hydraulic slips only work if the tubing pressure is higher than the annulus pressure above the packer. These packers are not suited to applications that require or anticipate tubing tension.

### **Retrievable Packers**

This type of packer is set using one of several methods and is fully locked against tubing and hydraulic forces in either direction. The Model 'SOT-1' and most hydraulic set packers are examples of this type of packer. Instead of hydraulically activated slips, these packers incorporate a set of bi-directional slips or have a set of upper and lower slips which anchor the packer from moving in either direction.

## Seal Bore Retrievable Packers

These packers are very similar to permanent seal bore packers when considering the forces applied and/or exerted on them. The 'Omegatrieve' retrievable packer is a typical retrievable seal bore packer.

## Hydraulic Forces and Single Grip Packers

With single grip packers, the piston effect is the primary force we are concerned with. Ballooning, temperature, etc. also affect the packer but not nearly as dramatically as hydraulic forces. Generally, any change which tends to lengthen the tubing string will adversely affect a tension packer. When considering a compression packer, upward acting forces that tend to shorten the tubing string are the main concern.

## Non-Equalizing Tension Packers

Pressure changes will act on the entire annular area of the packer, which can be very substantial. In the case of a model 'SA-3', a pressure differential in favor of the tubing (higher pressure below the packer) tends to push the packer body up, against the slips, transmitting the force to the casing. If the pressure is higher in the annulus above the packer, the generated force pushes down on the entire annular area, forcing the packer body away from the slips. In this case, the hydraulic force is transmitted through the packer's shear release system to the tubing string, lengthening the tubing string. If the generated downward force exceeds the initial tension pulled into the packer to set it, the packer will likely fail. The packer *will* fail if the generated force and initial setting tension combined are greater than the packer's shear value.

To release a tension packer such as an 'SA-3' requires enough tubing weight to overcome any hydraulic forces on the tool. It is extremely important to ensure that at the time of release, there is enough tubing weight or some means of equalizing the pressure differential across the packer. If a packer will not release due to hydraulic forces, it is commonly known as being 'hydraulically locked.'

Before installing a single grip tension packer, consider the following:

- The required tension for a desired amount of annulus pressure.
- The maximum change in tubing or annulus pressure for a given initial tension.
- How high to set the secondary shear release for the given program.

## 4

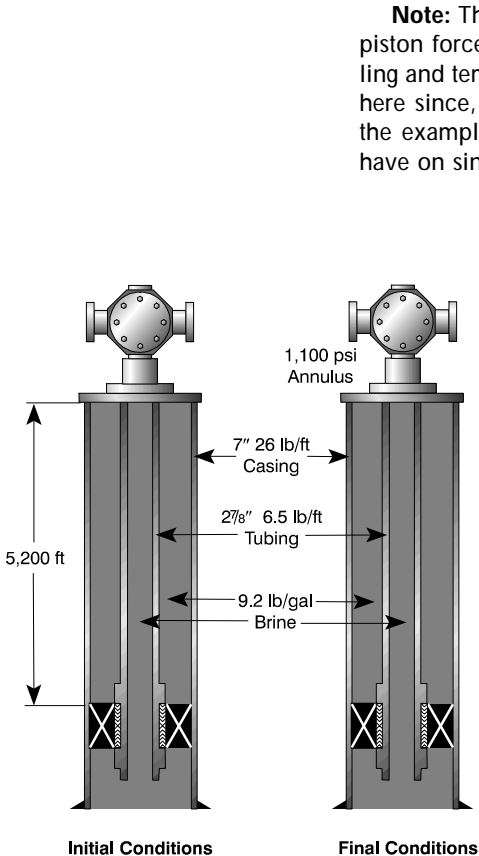

**Problem 4-1**

**Note:** The following examples determine only the hydraulic or piston forces on single grip packers. Although ballooning, buckling and temperature effects may also be present, they are ignored here since, in these examples they are minimal. The purpose of the examples is to illustrate the dramatic effect hydraulic forces have on single grip packers.

**Example Problem 4-1:**

An 'SA-3' retrievable packer is to be installed at 5,200 ft in the well shown in the figure. The oil company would like to pressure test the annulus at 1,100 psi. How much tension should the packer be set with and how high should the packer's shear value be set?

**Well Data:**

- Packer Depth: 5,200 ft
- Casing: 7" 26 lb/ft
- Tubing: 2 7/8" EUE 6.5 lb/ft
- Well Fluid: 9.2 lb/gal brine

There is 1,100 psi applied to the annulus.

**Solution:**

From the engineering tables:

- Casing ID area ( $A_{csg}$ ): 30.935 in<sup>2</sup>
- Tubing ID area ( $A_i$ ): 4.680 in<sup>2</sup>
- Tubing OD area ( $A_o$ ): 6.492 in<sup>2</sup>

As always, we are only concerned with any changes *after* the packer was set. In this case, the only change is the 1,100 psi applied to the annulus. Referring to the figure, the 1,100 psi will act downward on the entire annulus area above the packer. To balance the downward force, the packer must be set with at least the same amount of tension, neglecting the other effects.

# Schlumberger

## Tubing Calculations:

Change in Tubing Pressure ( $\Delta P_i$ ): 0 psi

## Annulus Calculations:

Change in Annulus Pressure ( $\Delta P_o$ ):

$$\Delta P_o = 1,100 \text{ psi}$$

## Piston Force:

$$\begin{aligned} F_1 &= \Delta P_o (A_{\text{csg}} - A_o) - \Delta P_i (A_{\text{csg}} - A_i) \\ &= 1,100 \text{ psi} (30.935 \text{ in}^2 - 6.492 \text{ in}^2) - 0 \text{ psi} \\ &= 26,887 \text{ lbs} \downarrow \end{aligned}$$

So, a minimum of 26,887 lbs tension is required. To determine the required shear value, we must look at the total load on the packer's shear release system. If the packer is set with 26,887 lbs tension, this much load is on the shear screws. When the annulus is pressure tested, an additional 26,887 lbs is placed on the shear screws. Therefore a total of 53,774 lbs is placed on the packer's shear release system. We do not want to exceed 80% of the shear value so:

$$\begin{aligned} \text{Shear Value} &= 53,774 \text{ lbs} \div .80 \\ &= 67,218 \text{ lbs} \end{aligned}$$

The shear value should therefore be set at 70,000 lbs. This does not include any forces due to temperature or ballooning. When determining the proper shear value, **all** forces on the packer must be taken into account.

## Example Problem 4-2:

An 'SA-3' retrievable packer is to be installed at 4,600 ft in the well shown in the figure. If the 'SA-3' is set with 12,000 lbs tension, how much annulus pressure may be safely applied without the elements moving down the well bore?

## 4

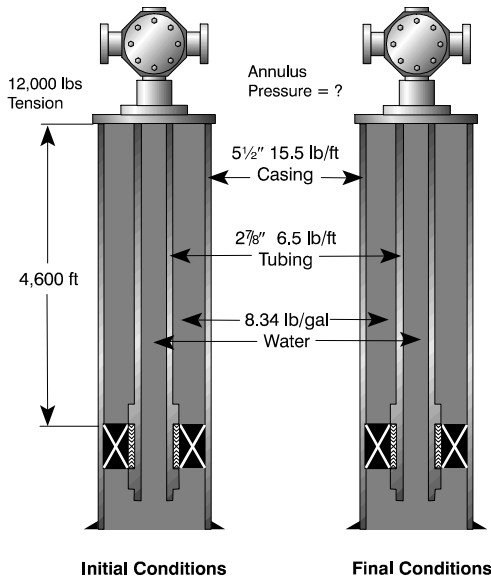

**Problem 4-2**

Well Data:

- Packer Depth: 4,600 ft
- Casing: 5 1/2" 15.5 lb/ft
- Tubing: 2 7/8" EUE 6.5 lb/ft
- Well Fluid: 8.34 lb/gal water

The packer is set with 12,000 lbs tension.

Solution:

From the engineering tables:

- Casing ID area ( $A_{csg}$ ): 19.244 in<sup>2</sup>
- Tubing ID area ( $A_i$ ): 4.680 in<sup>2</sup>
- Tubing OD area ( $A_o$ ): 6.492 in<sup>2</sup>

In this case we must solve for the maximum annulus test pressure. It will act on the annular area above the packer, and at most be equal to the initial setting tension.

**Tubing Calculations:**

Change in Tubing Pressure ( $\Delta P_i$ ): 0 psi

**Annulus Calculations:**

Change in Annulus Pressure ( $\Delta P_o$ ):

$$\Delta P_o = ?$$

**Piston Force:**

$$F_1 = \Delta P_o (A_{csg} - A_o) - \Delta P_i (A_{csg} - A_i)$$

$$12,000 \text{ lbs} \downarrow = \Delta P_o (19.244 \text{ in}^2 - 6.492 \text{ in}^2) - 0 \text{ psi}$$

$$\Delta P_o = \frac{12,000 \text{ lbs} \downarrow}{12.752 \text{ in}^2}$$

$$= 941 \text{ psi}$$

# Schlumberger

## Example Problem 4-3:

A tension packer is installed at 4,700 ft in 5½" 17 lb/ft casing. The tubing string is 2¾" 4.7 lb/ft. Both the tubing and annulus are full of 9.2 lb/gal salt water. If the packer is set with 12,000 lbs tension, how much fluid can be swabbed from the well?

Well Data:

Packer Depth: 4,700 ft  
 Casing: 5½" 17 lb/ft  
 Tubing: 2¾" EUE 4.7 lb/ft  
 Well Fluid: 9.2 lb/gal salt water

The packer is set with 12,000 lbs tension. Both the tubing and the annulus are full when the packer is set.

Solution:

From the engineering tables:

Casing ID area ( $A_{csg}$ ): 18.796 in<sup>2</sup>  
 Tubing ID area ( $A_t$ ): 3.126 in<sup>2</sup>  
 Tubing OD area ( $A_o$ ): 4.430 in<sup>2</sup>  
 Fluid Gradient ( $fg$ ): .478 psi /ft (128.5 psi/bbl)

By swabbing fluid from the tubing, the pressure underneath the packer is decreased. Dividing the total area under the packer by the initial setting tension will give the maximum pressure change. Divide this by the fluid gradient gives the depth (or volume) of the removed fluid.

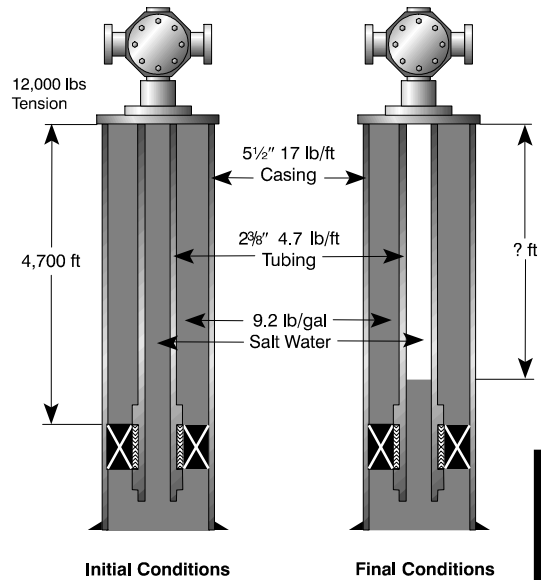

Problem 4-3

4



**Tubing Calculations:**

Change in Tubing Pressure,  $\Delta P_i = ?$

**Annulus Calculations:**

Change in Annulus Pressure ( $\Delta P_o$ ): 0 psi

**Piston Force:**

$$F_1 = \Delta P_o (A_{csg} - A_o) - \Delta P_i (A_{csg} - A_i)$$

$$12,000 \text{ lbs}\downarrow = 0 \text{ psi} - \Delta P_i (18.796 \text{ in}^2 - 3.126 \text{ in}^2)$$

$$\Delta P_i = \frac{12,000 \text{ lbs}\downarrow}{-15.670 \text{ in}^2}$$

$$= -766 \text{ psi}$$

**Fluid Removed:**

$$\text{Height: } h = \frac{\Delta P_i}{fg}$$

$$= \frac{-766 \text{ psi}}{.478 \text{ psi /ft}}$$

$$= -1,603 \text{ ft}$$

$$\text{Volume: } V = \frac{\Delta P_i}{fg}$$

$$= \frac{-766 \text{ psi}}{128.5 \text{ psi /bbl}}$$

$$= -5.96 \text{ bbl}$$

So, 1,603 ft or 5.96 bbls of fluid may be swabbed from the tubing.

**Example Problem 4-4:**

A packer is set with 14,000 lbs tension at 5,300 ft in 7" 20 lb/ft casing. The tubing string is 2<sup>7</sup>/<sub>8</sub>" 6.5 lb/ft. The well fluid is 8.8 lb/gal water, and was encountered at 3,850 ft. If the tubing and annulus are filled with 8.8 lb/gal water, what is the net hydraulic force on the packer?

# Schlumberger

Well Data:

- Packer Depth: 5,300 ft
- Casing: 7" 20 lb/ft
- Tubing: 2 7/8" EUE 6.5 lb/ft
- Well Fluid: 8.8 lb/gal water

The packer is set with 14,000 lbs tension. Both tubing and annulus are to be filled with 8.8 lb/gal water.

Solution:

From the engineering tables:

- Casing ID area ( $A_{csg}$ ): 32.735 in<sup>2</sup>
- Tubing ID area ( $A_t$ ): 4.680 in<sup>2</sup>
- Tubing OD area ( $A_o$ ): 6.492 in<sup>2</sup>
- Fluid Gradient ( $fg$ ): .458 psi/ft

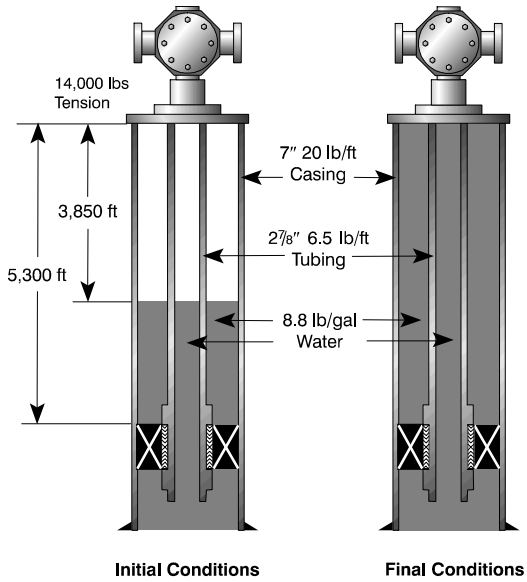

Problem 4-4

4

Since the area underneath the packer is more than the annular area above the packer, filling the well will create an upward force on the packer.

### Tubing Calculations:

Change in Tubing Pressure, ( $\Delta P_t$ ):

$$\begin{aligned} \Delta P_t &= fg \times h \\ &= .458 \text{ psi/ft} \times 3,850 \text{ ft} \\ &= 1,763 \text{ psi} \end{aligned}$$

### Annulus Calculations:

Change in Annulus Pressure,  $\Delta P_o = \Delta P_t = 1,763 \text{ psi}$

## 4

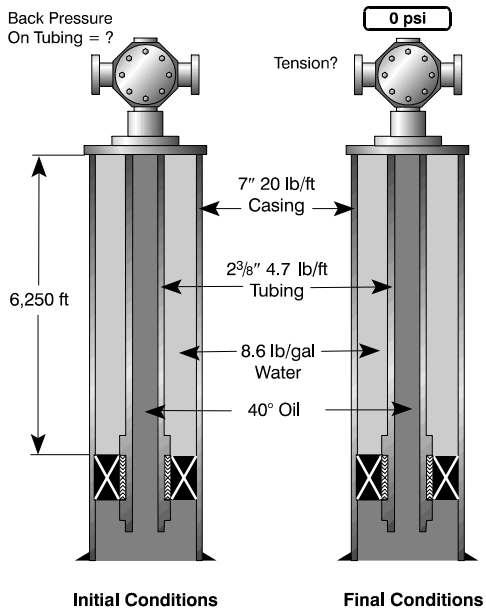

Problem 4-5

### Example Problem 4-5:

A tension packer is to be set at 6,250 ft in 7" 20 lb/ft casing on 2 3/8" 4.7 lb/ft tubing. The well is full of 40° gravity oil. The oil company wishes to circulate the annulus over to water before setting the packer. How much tension is required to hold the packer set once the back pressure is bled off the tubing?

#### Well Data:

- Packer Depth: 6,250 ft
- Casing: 7" 20 lb/ft
- Tubing: 2 3/8" EUE 4.7 lb/ft
- Annulus Fluid: 8.6 lb/gal water
- Tubing Fluid: 40° gravity oil

#### Solution:

From the engineering tables:

- Casing ID area ( $A_{csg}$ ): 32.735 in<sup>2</sup>
- Tubing ID area ( $A_i$ ): 3.126 in<sup>2</sup>
- Tubing OD area ( $A_o$ ): 4.430 in<sup>2</sup>
- Annulus Fluid Gradient (fg): .447 psi/ft
- Tubing Fluid Gradient (fg): .357 psi/ft

### Piston Force:

$$\begin{aligned}
 F &= \Delta P_o (A_{csg} - A_o) - \Delta P_i (A_{csg} - A_i) \\
 &= 1,763 \text{ psi} (32.735 \text{ in}^2 - 6.492 \text{ in}^2) \\
 &\quad - 1,763 \text{ psi} (32.735 \text{ in}^2 - 4.680 \text{ in}^2) \\
 &= 46,266 \text{ lbs} \downarrow - 49,461 \text{ lbs} \uparrow \\
 &= -3,195 \text{ lbs} \uparrow
 \end{aligned}$$

### Net Force on Packer:

$$\begin{aligned}
 F &= -14,000 \text{ lbs} \uparrow - 3,195 \text{ lbs} \uparrow \\
 &= -17,195 \text{ lbs} \uparrow
 \end{aligned}$$

# Schlumberger

Once the annulus is completely circulated to water, back pressure is held on the tubing to keep the oil from flowing. The packer is set and then the back pressure is bled off. Remember that the initial well conditions are those when the packer is set. So, the tubing pressure is what changes in this case. The change in tubing pressure is equal to the difference between the tubing and annulus fluid gradients multiplied by the total depth.

## Tubing Calculations:

Change in Tubing Pressure, ( $\Delta P_1$ ):

$$\begin{aligned}\Delta P_1 &= (f_{g_i} - f_{g_o}) \times h \\ &= (.357 \text{ psi/ft} - .447 \text{ psi/ft}) \times 6,250 \text{ ft} \\ &= -563 \text{ psi}\end{aligned}$$

(Since the tubing pressure is decreasing, the pressure change is negative)

## Annulus Calculations:

Change in Annulus Pressure,  $\Delta P_o = 0$  psi

## Piston Force:

$$\begin{aligned}F &= \Delta P_o (A_{csg} - A_o) - \Delta P_1 (A_{csg} - A_i) \\ &= 0 - (-563 \text{ psi}) \times (32.735 \text{ in}^2 - 3.126 \text{ in}^2) \\ &= 16,670 \text{ lbs}\downarrow\end{aligned}$$

So, the packer must be set with at least 16,670 lbs tension before bleeding off the tubing pressure.

## Compression Packers

A compression set packer such as a Model 'CA-3' uses tubing weight slacked off onto the tool to engage the slips and seal the packer elements against the casing wall. A pressure differential in favour of the annulus will increase the pack-off force on a compression packer. A pressure differential favouring the tubing will tend to push the packer body away from the slips. When dealing

4

## 4

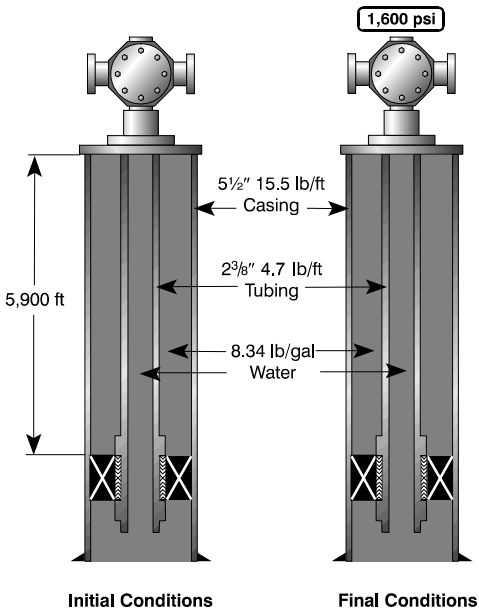

**Problem 4-6**

**Example Problem 4-6:**

A 'CA-3' retrievable packer is set a 5,900 ft in 5 1/2" 15.5 lb/ft casing on 2 3/8" 4.7 lb/ft tubing. The well fluid is 8.34 lb/gal water. The oil company wants to pressure test the tubing to 1,600 psi surface pressure. How much weight must be set on the 'CA-3' to compensate for the pressure test?

**Well Data:**

- Packer Depth: 5,900 ft
- Casing: 5 1/2" 15.5 lb/ft
- Tubing: 2 3/8" EUE 4.7 lb/ft
- Initial Well Fluid: 8.34 lb/gal water

Tubing and annulus are full.

1,600 psi applied to tubing.

**Solution:**

From the engineering tables:

- Casing ID area ( $A_{csg}$ ): 19.244 in<sup>2</sup>
- Tubing ID area ( $A_i$ ): 3.126 in<sup>2</sup>
- Tubing OD area ( $A_o$ ): 4.430 in<sup>2</sup>
- Well fluid gradient ( $f_{gi}$ ): .434 psi/ft

# Schlumberger

## Tubing Calculations:

Change in Tubing Pressure,  $\Delta P_i = 1,600$  psi

## Annulus Calculations:

Change in Annulus Pressure,  $\Delta P_o = 0$  psi

Since there is no change in the annulus pressure, the hydraulic force on the packer is the applied tubing pressure times the area underneath the packer.

## Piston Force:

$$\begin{aligned} F &= \Delta P_o (A_{csg} - A_o) - \Delta P_i (A_{csg} - A_i) \\ &= 0 \text{ psi } (19.244 \text{ in}^2 - 4.430 \text{ in}^2) \\ &\quad - 1,600 \text{ psi } (19.244 \text{ in}^2 - 3.126 \text{ in}^2) \\ &= -25,789 \text{ lbs} \uparrow \end{aligned}$$

So, a minimum of 25,789 lbs of tubing weight must **reach** the packer.

## Example Problem 4-7:

A model 'CA-3' is set at 6,500 ft in 5½" 17 lb/ft casing on 2⅞" 6.5 lb/ft tubing. The packer was set with 16,500 lbs of weight on it. How much pressure can be applied to the tubing without releasing the packer?

Well Data:

Packer Depth: 6,500 ft  
 Casing: 5½" 17.0 lb/ft  
 Tubing: 2⅞" EUE 6.5 lb/ft  
 Well Fluid: 8.34 lb/gal water

Tubing and annulus are full.

Packer set with 16,500 lbs compression.

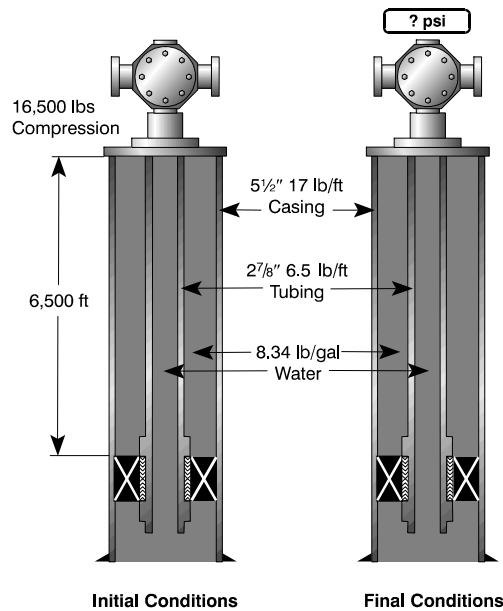

Problem 4-7

4

Solution:

From the engineering tables:

Casing ID area ( $A_{csg}$ ):	18.796 in <sup>2</sup>
Tubing ID area ( $A_i$ ):	4.680 in <sup>2</sup>
Tubing OD area ( $A_o$ ):	6.492 in <sup>2</sup>
Well fluid gradient (fg):	.434 psi/ft

**Tubing Calculations:**

Change in Tubing Pressure,  $\Delta P_i = ?$  psi

**Annulus Calculations:**

Change in Annulus Pressure,  $\Delta P_o = 0$  psi

The maximum applied tubing pressure multiplied by the area underneath the packer cannot exceed the weight set on the packer. Dividing the weight on the packer by the area underneath the packer gives the maximum tubing pressure change.

**Piston Force:**

$$\begin{aligned}
 F &= \Delta P_o (A_{csg} - A_o) - \Delta P_i (A_{csg} - A_i) \\
 16,500 \text{ lbs} \downarrow &= 0 \text{ psi} (18.796 \text{ in}^2 - 6.492 \text{ in}^2) \\
 &\quad - \Delta P_i (18.796 \text{ in}^2 - 4.680 \text{ in}^2) \\
 \Delta P_i &= \frac{16,500 \text{ lbs}}{(18.796 \text{ in}^2 - 4.680 \text{ in}^2)} \\
 &= 1,169 \text{ psi}
 \end{aligned}$$

So, a maximum of 1,169 psi of pressure may be applied to the tubing.

**Example Problem 4-8:**

A compression packer is set at 5,900 ft in 5<sup>1</sup>/<sub>2</sub>" 15.5 lb/ft casing on 2<sup>3</sup>/<sub>8</sub>" 4.7 lb/ft tubing. The packer was landed with 16,000 lbs on it. The well fluid is 9.2 lb/gal salt water. The oil company

# Schlumberger

wants to apply 2,300 psi to the tubing. How much pressure must be applied to the annulus to hold the packer set?

Well Data:

Packer Depth: 5,900 ft  
 Casing: 5 1/2" 15.5 lb/ft  
 Tubing: 2 3/8" EUE 4.7 lb/ft  
 Well Fluid: 9.2 lb/gal salt water

Tubing and annulus are full.  
 2,300 psi applied to tubing.  
 Packer has 16,000 lbs compression on it.

Solution:

From the engineering tables:

Casing ID area ( $A_{csg}$ ): 19.244 in<sup>2</sup>  
 Tubing ID area ( $A_i$ ): 3.126 in<sup>2</sup>  
 Tubing OD area ( $A_o$ ): 4.430 in<sup>2</sup>  
 Well fluid gradient ( $f_g$ ): .478 psi/ft

### Tubing Calculations:

Change in Tubing Pressure,  $\Delta P_i = 2,300$  psi

### Annulus Calculations:

Change in Annulus Pressure,  $\Delta P_o = ?$  psi

At the very least, the hydraulic force on the packer must not exceed the weight set on the packer.

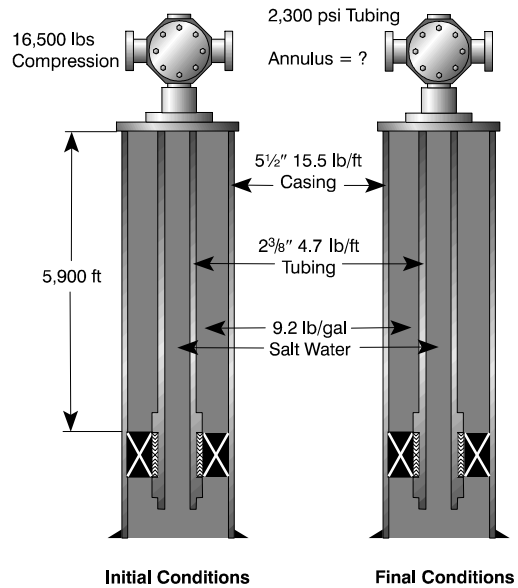

Problem 4-8

4



## 4

**Piston Force:**

$$\begin{aligned}
 F &= \Delta P_o (A_{csg} - A_o) - \Delta P_i (A_{csg} - A_i) \\
 16,000 \text{ lbs} \downarrow &= \Delta P_o (19.244 \text{ in}^2 - 4.430 \text{ in}^2) \\
 &\quad - 2,300 \text{ psi} (19.244 \text{ in}^2 - 3.126 \text{ in}^2) \\
 \Delta P_o &= \frac{-16,000 \text{ lbs} + 2,300 \text{ psi} (19.244 \text{ in}^2 - 3.126 \text{ in}^2)}{(19.244 \text{ in}^2 - 4.430 \text{ in}^2)} \\
 &= \frac{-16,000 \text{ lbs} + 37,071 \text{ lbs}}{14.814 \text{ in}^2} \\
 &= 1,422 \text{ psi}
 \end{aligned}$$

So, a minimum of 1,422 psi must be applied to the annulus to balance the hydraulic force created by the applied tubing pressure.

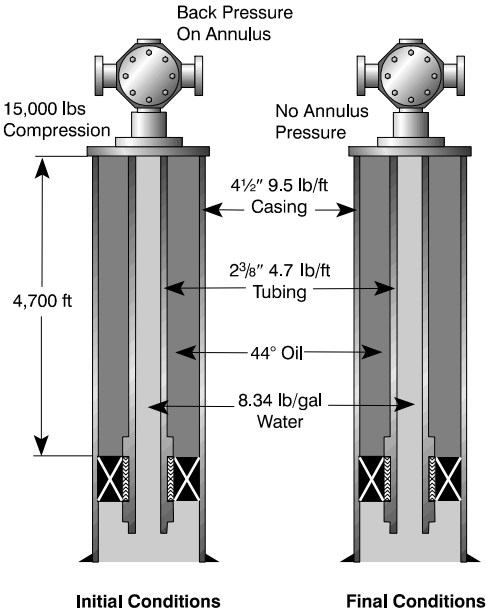

**Problem 4-9**

**Example Problem 4-9:**

A compression packer is set with 15,000 lbs compression at 4,700 ft in 4 1/2" 9.5 lb/ft casing on 2 3/8" 4.7 lb/ft tubing. The well is full of 44° API oil. The oil company wishes to circulate water down to the packer before setting the packer. What is the net force on the packer after setting the packer and bleeding off the annulus pressure?

**Well Data:**

- Packer Depth: 4,700 ft
- Casing: 4 1/2" 9.5 lb/ft
- Tubing: 2 3/8" EUE 4.7 lb/ft
- Initial Well Fluid: 44° API Oil
- Final Tubing Fluid: 8.34 lb/gal water

Packer set with 15,000 lbs compression.

# Schlumberger

Solution:

From the engineering tables:

Casing ID area ( $A_{csg}$ ):	13.138 in <sup>2</sup>
Tubing ID area ( $A_i$ ):	3.126 in <sup>2</sup>
Tubing OD area ( $A_o$ ):	4.430 in <sup>2</sup>
Tubing fluid gradient ( $fg_i$ ):	.434 psi/ft
Annulus fluid gradient ( $fg_o$ ):	.350 psi/ft

## Tubing Calculations:

Change in Tubing Pressure,  $\Delta P_i = 0$  psi

## Annulus Calculations:

Change in Annulus Pressure, ( $\Delta P_o$ ):

The change in annulus pressure will be equal to the difference between the tubing fluid gradient and the annulus fluid gradient times the packer depth. This is how much back pressure must be held on the annulus to keep the oil from flowing out.

$$\begin{aligned}\Delta P_o &= (fg_o - fg_i) \times h \\ &= (.350 \text{ psi/ft} - .434 \text{ psi /ft}) \times 4,700 \text{ ft} \\ &= -395 \text{ psi}\end{aligned}$$

## Piston Force:

$$\begin{aligned}F &= \Delta P_o (A_{csg} - A_o) - \Delta P_i (A_{csg} - A_i) \\ &= -395 \text{ psi} (13.138 \text{ in}^2 - 4.430 \text{ in}^2) \\ &\quad - 0 \text{ psi} (13.138 \text{ in}^2 - 3.126 \text{ in}^2) \\ &= -3,440 \text{ lb}\uparrow\end{aligned}$$

The net force on the tool (neglecting temperature and ballooning etc.) is the piston force plus the weight set on the packer.

$$\begin{aligned}F_n &= \text{Setting Weight} + F \\ &= 15,000 \text{ lb}\downarrow + (-3440 \text{ lbs}\uparrow) \\ &= 11,560 \text{ lbs}\downarrow\end{aligned}$$

## Hydraulic Forces and Double Grip Packers

Since double grip packers are available in such a wide variety of models, it is necessary to consult the technical manual for the specific packer. For any application that involves high pressure or temperature changes, it is strongly recommended to use the 'Packer and Tubing Force Program' to get a complete analysis of the forces resulting from the changes.

When using a double grip packer, consider the following questions and issues:

- Will the generated forces from expected conditions exceed the safe ratings of the tubing or packer components?
- Will the generated forces exceed the shear value of the packer? A general rule of thumb is to never exceed 70 to 75 percent of the total shear value.
- For a compression set double grip packer with hydraulic hold downs, will the tubing remain in compression during the expected conditions? Tubing tension may cause the packer to release.
- Double grip retrievable packers such as the 'Model T' retrievable packer do not have an internal pressure equalizing system. Any pressure differential across the tool must be balanced before releasing the packer.
- When running multiple hydraulic packer installations, the tubing forces that are generated between the packers may unintentionally release the secondary shear release systems of the other packers. It may be necessary to use an expansion device to compensate for the forces.

## Hook-Loads

The rig weight indicator reading is generally known as "hook-load". In chapter 3, the difference between the tubing size and the packer seal bore was ignored. In most cases, the tubing is larger or smaller than the packer seal bore. Pressure in the tubing and annulus act on the differences in areas, creating forces that affect the hook-load. This chapter covers calculating hook-loads to release seal assemblies in permanent and seal bore packers.

In this chapter, several assumptions are made to simplify the problem solving. In the first part of the chapter, it is assumed the tubing is free to move up or down. Later, different types of seal assemblies are discussed. As well, this chapter assumes that the seal between the tubing and packer is maintained at all times. The casing absorbs any forces on the packer body and does not affect the hook-load. Finally, no other effects such as buckling, ballooning or temperature are considered here.

## Tubing O.D. Smaller Than Packer Bore

Most often, the packer seal bore is larger than the tubing O.D. Figure 4.1 is a schematic illustration of such a case. Tubing pressure ( $P_i$ ) acts up on the difference between the packer seal bore area ( $A_p$ ) and the tubing I.D. area ( $A_i$ ), creating an upward acting force ( $F_1$ ). Annulus pressure ( $P_o$ ) will act down on the difference between the packer seal bore area ( $A_p$ ) and the tubing O.D. area ( $A_o$ ), creating a downward acting force ( $F_2$ ). Force ' $F_1$ ' will tend to reduce the hook-load and ' $F_2$ ' will tend to increase it. The step by step calculations to determine the hook-load are:

### Tubing:

1. Calculate the total tubing pressure at the packer ( $P_i$ ). The total pressure is the sum of the hydrostatic pressure and any pressure applied at the surface.
2. Find the difference between the packer seal bore area and the tubing I.D. area ( $A_1 = A_p - A_i$ ).
3. Calculate force ' $F_1$ ' by multiplying the total pressure, ( $P_i$  in Step 1) by the difference in areas ( $A_1$  in Step 2).

### Annulus:

4. Calculate the total annulus pressure at the packer ( $P_o$ ). Total pressure is hydrostatic plus applied.
5. Find the difference between the packer seal bore area and the tubing O.D. area, ( $A_2 = A_p - A_o$ ).
6. Calculate ' $F_2$ ' by multiplying the total pressure ( $P_o$  in step 4) by the difference in areas ( $A_2$  in Step 5).

### Tubing Weight:

7. Calculate the tubing weight in air ( $W_i$ ) using equation 3-2.

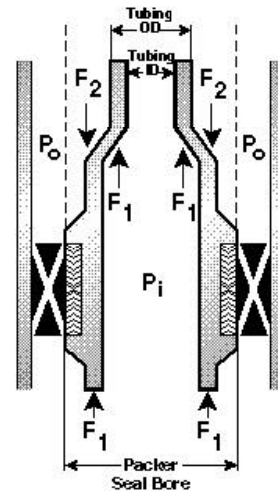
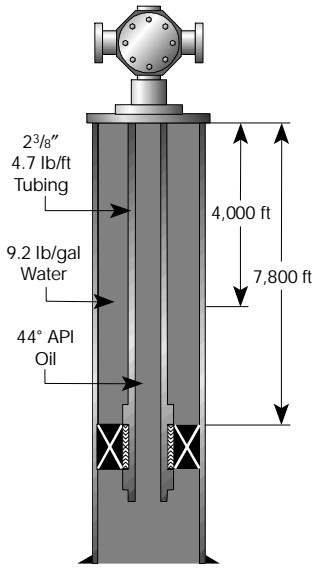

Figure 4.1

## 4



### Hook-Load:

8. Calculate the hook-load by combining 'F<sub>1</sub>' (Step 3) 'F<sub>2</sub>' (Step 6), and the tubing string weight, 'W<sub>t</sub>' (Step 7). Keep track of which way the forces are acting.

### Example Problem 4-10:

What is the hook-load at the surface under the following conditions?

Packer Depth =	7,800 ft
Tubing Size =	2 3/8" 4.7 lbs/ft
Packer Seal Bore =	3.00"
Annulus Fluid =	9.2 lbs/gal water
Tubing Fluid =	44° API oil
Tubing Fluid Level =	4,000 ft

There is no applied pressure to either the tubing or the annulus.

Solution:

From the engineering tables:

Fluid Gradient of 44° API oil, (fg <sub>i</sub> ): =	.350 psi/ft
Fluid Gradient of 9.2 lbs/gal water, (fg <sub>o</sub> ): =	.478 psi/ft
Packer Seal Bore Area, (A <sub>p</sub> ): =	7.069 in <sup>2</sup>
Tubing I.D. Area, (A <sub>i</sub> ): =	3.126 in <sup>2</sup>
Tubing O.D. Area, (A <sub>o</sub> ): =	4.430 in <sup>2</sup>

### Tubing Calculations:

1. Total tubing pressure at the packer (P<sub>i</sub>):

Since there is no pressure applied at the surface, the total tubing pressure is the hydrostatic pressure in the tubing. The fluid level is at 4,000 ft, so the hydrostatic pressure is due to the fluid column height.

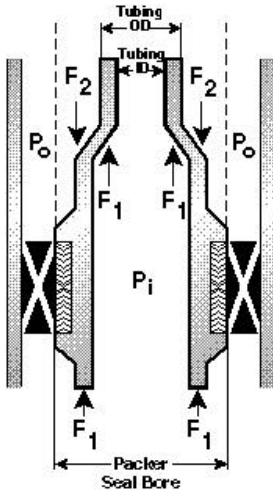

Problem 4-10

# Schlumberger

$$\begin{aligned}P_1 &= fg_i \times h_i \\&= .350 \text{ psi/ft} \times (7,800 \text{ ft} - 4,000 \text{ ft}) \\&= .350 \text{ psi/ft} \times 3,800 \text{ ft} \\&= 1,330 \text{ psi}\end{aligned}$$

2. Difference between packer seal bore area and tubing I.D. area ( $A_1$ ):

$$\begin{aligned}A_1 &= A_p - A_i \\&= 7.069 \text{ in}^2 - 3.126 \text{ in}^2 \\&= 3.943 \text{ in}^2\end{aligned}$$

3. Force ' $F_1$ ':

$$\begin{aligned}F_1 &= P_1 \times A_1 \\&= 1,330 \text{ psi} \times 3.943 \text{ in}^2 \\&= 5,243 \text{ lbs } \uparrow\end{aligned}$$

4

## Annulus Calculations:

4. Total annulus pressure at the packer ( $P_o$ ):

Since there is no pressure applied at the surface, the total annulus pressure is the hydrostatic pressure in the annulus.

$$\begin{aligned}P_o &= fg_o \times h_o \\&= .478 \text{ psi/ft} \times 7,800 \text{ ft} \\&= 3,728 \text{ psi}\end{aligned}$$

5. Difference between packer seal bore area and tubing O.D. area ( $A_2$ ):

$$\begin{aligned}A_2 &= A_p - A_o \\&= 7.069 \text{ in}^2 - 4.430 \text{ in}^2 \\&= 2.639 \text{ in}^2\end{aligned}$$

4

6. Force 'F<sub>2</sub>':

$$\begin{aligned}
 F_2 &= P_o \times A_2 \\
 &= 3,728 \text{ psi} \times 2.639 \text{ in}^2 \\
 &= 9,838 \text{ lbs} \downarrow
 \end{aligned}$$

7. Weight of tubing in air (W<sub>t</sub>):

$$\begin{aligned}
 W_t &= \omega \times L \\
 &= 4.7 \text{ lbs/ft} \times 7,800 \text{ ft} \\
 &= 36,660 \text{ lbs} \downarrow
 \end{aligned}$$

8. Hook Load (W<sub>hl</sub>):

$$\begin{aligned}
 W_{hl} &= W_t + F_1 + F_2 \\
 &= 36,660 \downarrow + (- 5,243 \text{ lbs} \uparrow) + 9,838 \text{ lbs} \downarrow \\
 &= 41,255 \text{ lbs} \downarrow
 \end{aligned}$$

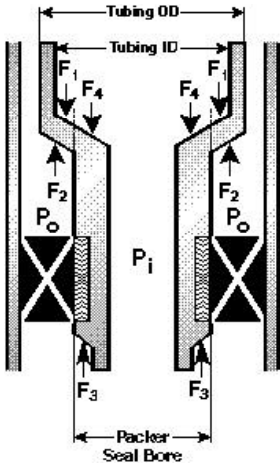

Figure 4.2

**Tubing O.D. and I.D. Larger than Packer Seal Bore**

Figure 4.2 is an illustration of a situation where both the tubing O.D. and I.D. are larger than the packer seal bore. Tubing pressure creates the forces 'F<sub>3</sub>' and 'F<sub>4</sub>' which act on the difference between the packer seal bore area (A<sub>p</sub>) and the packer I.D. area (A<sub>i</sub>). 'F<sub>3</sub>' and 'F<sub>4</sub>' act on the same area in opposite directions and tend to cancel one another. (Technically, there is a slight difference in the tubing pressure between the top and bottom of the packer, making 'F<sub>3</sub>' slightly larger than 'F<sub>4</sub>'. However, the difference is so small it may be neglected.) Tubing pressure acting on the difference between the packer seal bore area (A<sub>p</sub>) and the tubing I.D. area (A<sub>i</sub>) creates a downward acting force (F<sub>1</sub>). Annulus pressure acting on the difference between the packer seal bore area (A<sub>p</sub>) and the tubing O.D. area (A<sub>o</sub>) will create an upward acting force (F<sub>2</sub>).

The steps necessary to determine the hook-load are as follows:

# Schlumberger

## Tubing:

1. Calculate the total tubing pressure at the packer ( $P_i$ ). The total pressure is the sum of the hydrostatic pressure and any pressure applied at the surface.
2. Find the difference between the packer seal bore area and the tubing I.D. area ( $A_1 = A_p - A_i$ ).
3. Calculate ' $F_1$ ' by multiplying the total pressure ( $P_i$  in Step 1) by the difference in areas ( $A_1$  in Step 3).

## Annulus:

4. Calculate the total annulus pressure at the packer ( $P_o$ ), (hydrostatic plus applied).
5. Find the difference between the tubing O.D. area and the packer seal bore area ( $A_2 = A_o - A_p$ ).
6. Calculate ' $F_2$ ' by multiplying the total pressure ( $P_o$  in Step 4) by the difference in areas ( $A_2$  in Step 5).

## Tubing Weight:

7. Calculate the tubing weight in air ( $W_t$ ) using equation 3-2.

## Hook-Load:

8. Calculate the hook-load by combining ' $F_1$ ' (Step 3) ' $F_2$ ' (Step 6), and the tubing string weight, ' $W_t$ ' (Step 7). Keep track of which way the forces are acting.

## Example Problem 4-11:

What is the hook-load at the surface under the following conditions?

Packer Depth = 6,300 ft

Tubing Size = 3 $\frac{1}{2}$ " 9.3 lbs/ft

Packer Seal Bore = 2.688"

Annulus Fluid = 8.34 lbs/gal water

Tubing Fluid = 40° API oil

There is no applied pressure to either the tubing or the annulus.

4



## 4

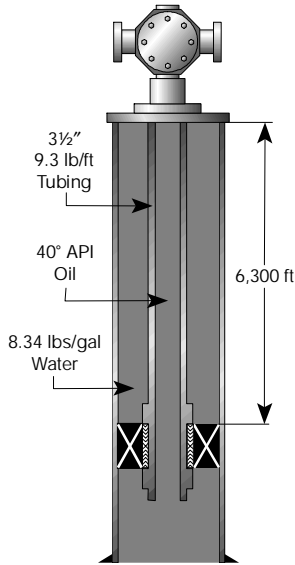

Solution:

From the engineering tables:

Fluid Gradient of 40° API oil, ( $fg_i$ ) =	.358 psi/ft
Fluid Gradient of 8.34 lbs/gal water, ( $fg_o$ ) =	.434 psi/ft
Packer Seal Bore Area, ( $A_p$ ) =	5.675 in <sup>2</sup>
Tubing I.D. Area, ( $A_i$ ) =	7.031 in <sup>2</sup>
Tubing O.D. Area, ( $A_o$ ) =	9.621 in <sup>2</sup>

**Tubing Calculations:**

- Total tubing pressure at the packer ( $P_i$ ):  
Since there is no pressure applied at the surface, the total tubing pressure is the hydrostatic pressure in the tubing.

$$\begin{aligned}
 P_i &= fg_i \times h_i \\
 &= .358 \text{ psi/ft} \times 6,300 \text{ ft} \\
 &= 2,255 \text{ psi}
 \end{aligned}$$

- Difference between tubing I.D. area and packer seal bore area, ( $A_1$ ):

$$\begin{aligned}
 A_1 &= A_i - A_p \\
 &= 7.031 \text{ in}^2 - 5.675 \text{ in}^2 \\
 &= 1.356 \text{ in}^2
 \end{aligned}$$

- Force ' $F_1$ ':

$$\begin{aligned}
 F_1 &= P_i \times A_1 \\
 &= 2,255 \text{ psi} \times 1.356 \text{ in}^2 \\
 &= 3,058 \text{ lbs} \downarrow
 \end{aligned}$$

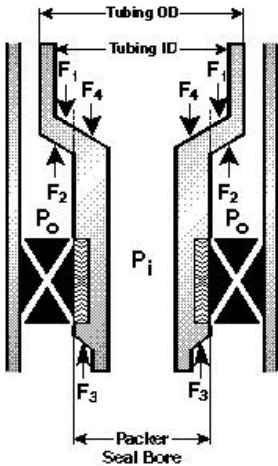

Problem 4-11

# Schlumberger

## Annulus Calculations:

4. Total annulus pressure at the packer ( $P_o$ ):

Since there is no pressure applied at the surface, the total annulus pressure is the hydrostatic pressure in the annulus.

$$\begin{aligned} P_o &= f_{g_o} \times h_o \\ &= .434 \text{ psi/ft} \times 6,300 \text{ ft} \\ &= 2,734 \text{ psi} \end{aligned}$$

5. Difference between tubing O.D. area and packer seal bore area ( $A_2$ ):

$$\begin{aligned} A_2 &= A_o - A_p \\ &= 9.621 \text{ in}^2 - 5.675 \text{ in}^2 \\ &= 3.946 \text{ in}^2 \end{aligned}$$

6. Force ' $F_2$ ':

$$\begin{aligned} F_2 &= P_o \times A_2 \\ &= 2,734 \text{ psi} \times 3.946 \text{ in}^2 \\ &= 10,789 \text{ lbs} \uparrow \end{aligned}$$

7. Weight of tubing in air ( $W_t$ ):

$$\begin{aligned} W_t &= \omega \times L \\ &= 9.3 \text{ lbs/ft} \times 6,300 \text{ ft} \\ &= 58,590 \text{ lbs} \downarrow \end{aligned}$$

8. Hook Load ( $W_{hl}$ ):

$$\begin{aligned} W_{hl} &= W_t + F_1 + F_2 \\ &= 58,590 \text{ lbs} \downarrow + 3,058 \text{ lbs} \downarrow + (-10,789 \text{ lbs} \uparrow) \\ &= 50,859 \text{ lbs} \downarrow \end{aligned}$$

4

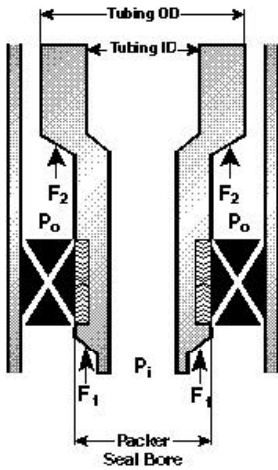

Figure 4.3

4

## Tubing O.D. Larger than Packer Seal Bore and Tubing I.D. Smaller Than Packer Seal Bore

Figure 4.3 is an illustration of the unique combination of 27/8" 6.5 lb/ft tubing and a packer seal bore of 2.688". In this case, the tubing O.D. is larger than the packer seal bore and the tubing I.D. is smaller than the packer seal bore. Tubing pressure acting on the difference between the packer seal bore area ( $A_p$ ) and the tubing I.D. area ( $A_i$ ) creates an upward acting force ( $F_1$ ). Annulus pressure acting on the difference between the tubing O.D. area ( $A_o$ ) and the packer seal bore area ( $A_p$ ) will also create an upward acting force ( $F_2$ ).

The steps necessary to determine the hook-load are as follows:

### Tubing:

1. Calculate the total tubing pressure at the packer ( $P_i$ ). The total pressure is the sum of the hydrostatic pressure and any pressure applied at the surface.
2. Find the difference between the packer seal bore area, and the tubing I.D. area ( $A_1 = A_p - A_i$ ).
3. Calculate ' $F_1$ ' by multiplying the total pressure, ( $P_i$  in Step 1) by the difference in areas ( $A_1$  in Step 2).

### Annulus:

4. Calculate the total annulus pressure at the packer ( $P_o$ ), (hydrostatic plus applied).
5. Find the difference between the tubing O.D. area and the packer seal bore area ( $A_2 = A_o - A_p$ ).
6. Calculate ' $F_2$ ' by multiplying the total pressure ( $P_o$  in Step 4) by the difference in areas ( $A_2$  in Step 5).

### Tubing Weight:

7. Calculate the tubing weight in air ( $W_t$ ) using equation 3-2.

### Hook-Load:

8. Calculate the hook-load by combining ' $F_1$ ' (Step 3) ' $F_2$ ' (Step 6), and the tubing string weight, ' $W_t$ ' (Step 7). Keep track of which way the forces are acting.

# Schlumberger

## Example Problem 4-12:

What is the hook-load at the surface under the following conditions?

- Packer Depth = 5,200 ft
- Tubing Size = 2 7/8" 6.5 lbs/ft
- Packer Seal Bore = 2.688"
- Annulus Fluid = 9.0 lbs/gal water
- Tubing Fluid = 8.9 lbs/gal acid
- Applied Pressure = 1,500 psi on tubing

Solution:

From the engineering tables:

- Fluid Gradient of 8.9 lbs/gal acid, ( $fg_i$ ) = .463 psi/ft
- Fluid Gradient of 9.0 lbs/gal water, ( $fg_o$ ) = .468 psi/ft
- Packer Seal Bore Area, ( $A_p$ ) = 5.675 in<sup>2</sup>
- Tubing I.D. Area, ( $A_i$ ) = 4.680 in<sup>2</sup>
- Tubing O.D. Area, ( $A_o$ ) = 6.492 in<sup>2</sup>

### Tubing Calculations:

1. Total tubing pressure at the packer ( $P_i$ ):

Tubing hydrostatic pressure ( $P_{hydro}$ ):

$$\begin{aligned}
 P_{hydro} &= fg_i \times h_i \\
 &= .463 \text{ psi/ft} \times 5,200 \text{ ft} \\
 &= 2,408 \text{ psi}
 \end{aligned}$$

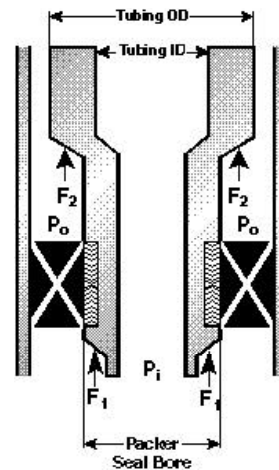
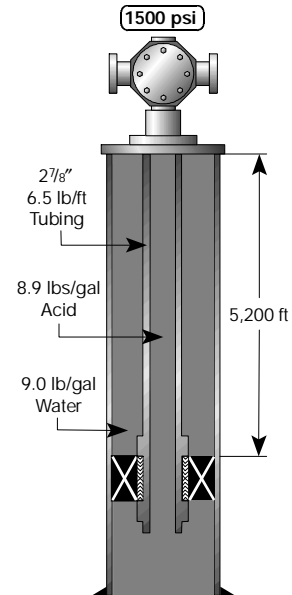

Problem 4-12

Total tubing pressure is hydrostatic plus applied:

$$\begin{aligned} P_i &= P_{hydro} + P_{app} \\ &= 2,408 \text{ psi} + 1,500 \text{ psi} \\ &= 3,908 \text{ psi} \end{aligned}$$

2. Difference between packer seal bore area and tubing I.D. area, ( $A_1$ ):

$$\begin{aligned} A_1 &= A_p - A_i \\ &= 5.675 \text{ in}^2 - 4.680 \text{ in}^2 \\ &= .995 \text{ in}^2 \end{aligned}$$

3. Force ' $F_1$ ':

$$\begin{aligned} F_1 &= P_i \times A_1 \\ &= 3,908 \text{ psi} \times .995 \text{ in}^2 \\ &= 3,888 \text{ lbs } \uparrow \end{aligned}$$

#### Annulus Calculations:

4. Total annulus pressure at the packer ( $P_o$ ):

Since there is no pressure applied to the annulus at the surface the total annulus pressure is the hydrostatic pressure in the annulus.

$$\begin{aligned} P_o &= fg_o \times h_o \\ &= .468 \text{ psi/ft} \times 5,200 \text{ ft} \\ &= 2,434 \text{ psi} \end{aligned}$$

5. Difference between tubing O.D. area and packer seal bore area ( $A_2$ ):

$$\begin{aligned} A_2 &= A_o - A_p \\ &= 6.492 \text{ in}^2 - 5.675 \text{ in}^2 \\ &= .817 \text{ in}^2 \end{aligned}$$

6. Force 'F<sub>2</sub>':

$$\begin{aligned}F_2 &= P_o \times A_2 \\&= 2,434 \text{ psi} \times .817 \text{ in}^2 \\&= 1,989 \text{ lbs} \uparrow\end{aligned}$$

7. Weight of tubing in air (W<sub>t</sub>):

$$\begin{aligned}W_t &= \omega \times L \\&= 6.5 \text{ lbs/ft} \times 5,200 \text{ ft} \\&= 33,800 \text{ lbs} \downarrow\end{aligned}$$

8. Hook Load (W<sub>hl</sub>):

$$\begin{aligned}W_{hl} &= W_t + F_1 + F_2 \\&= 33,800 \text{ lbs} \downarrow + (-3,888 \text{ lbs} \uparrow) + (-1,989 \text{ lbs} \uparrow) \\&= 27,923 \text{ lbs} \downarrow\end{aligned}$$

4

## General Hook Load Calculations for Unplugged Tubing

The step by step procedures in the previous sections can be written as an equation, eliminating the need to remember each step. As well, the equation accounts for the different sizes of tubing and packer seal bores. The equation for the hook-load of tubing free to move in the seal bore is:

$$\text{Hook-Load} = \text{Tubing Weight} - \text{Buoyancy Forces} \quad (4-1)$$

or

$$W_{hl} = (\omega \times L) - [P_o(A_o - A_p) + P_i(A_p - A_i)] \quad (4-2)$$

## 4

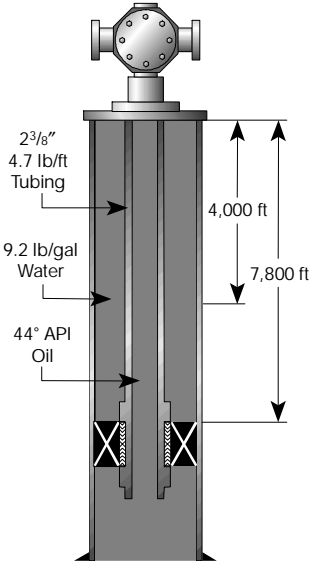

where:

- $A_i$  = tubing I.D. area (in<sup>2</sup>)
- $A_o$  = tubing O.D. area (in<sup>2</sup>)
- $A_p$  = packer seal bore area (in<sup>2</sup>)
- $L$  = total length of tubing (ft)
- $P_i$  = total tubing pressure @ packer (psi)
- $P_o$  = total annulus pressure @ packer (psi)
- $W_{hl}$  = hook-load (lbs)
- $\omega$  = linear weight per foot of tubing (lbs/ft)

**Example Problem 4-13:**

This problem is the same as Example Problem 4-10. What is the hook-load at the surface under the following conditions?

- Packer Depth = 7,800 ft
- Tubing Size = 2 3/8" 4.7 lbs/ft
- Packer Seal Bore = 3.00"
- Annulus Fluid = 9.2 lbs/gal water
- Tubing Fluid = 44° API oil
- Tubing Fluid Level = 4,000 ft

There is no applied pressure to either the tubing or the annulus.

Solution:

From the engineering tables:

- Fluid Gradient of 44° API oil, (fg<sub>i</sub>) = .350 psi/ft
- Fluid Gradient of 9.2 lbs/gal water, (fg<sub>o</sub>) = .478 psi/ft
- Packer Seal Bore Area, (A<sub>p</sub>) = 7.069 in<sup>2</sup>

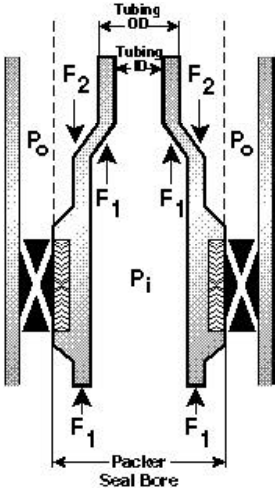

Problem 4-13

# Schlumberger

$$\text{Tubing I.D. Area, } (A_i) = 3.126 \text{ in}^2$$

$$\text{Tubing O.D. Area, } (A_o) = 4.430 \text{ in}^2$$

There are no applied pressures, so:

Total Tubing Pressure at the Packer ( $P_i$ ):

$$\begin{aligned} P_i &= f_{g_i} \times h_i \\ &= .350 \text{ psi/ft} \times (7,800 \text{ ft} - 4,000 \text{ ft}) \\ &= .350 \text{ psi/ft} \times 3,800 \text{ ft} \\ &= 1,330 \text{ psi} \end{aligned}$$

Total Annulus Pressure at the Packer ( $P_o$ ):

$$\begin{aligned} P_o &= f_{g_o} \times h_o \\ &= .478 \text{ psi/ft} \times 7,800 \text{ ft} \\ &= 3,728 \text{ psi} \end{aligned}$$

Hook-Load ( $W_{hl}$ ):

$$\begin{aligned} W_{hl} &= (\omega \times L) - [P_o (A_o - A_p) + P_i (A_p - A_i)] \\ &= (4.7 \text{ lbs/ft} \times 7,800 \text{ ft}) \\ &\quad - [3,728 \text{ psi} (4.430 \text{ in}^2 - 7.069 \text{ in}^2) \\ &\quad + 1,330 \text{ psi} (7.069 \text{ in}^2 - 3.126 \text{ in}^2)] \\ &= 36,660 \text{ lbs} - [3,728 \text{ psi} (-2.639 \text{ in}^2) \\ &\quad + 1,330 \text{ psi} (3.943 \text{ in}^2)] \\ &= 36,660 \text{ lbs} - [-9,838 \text{ lbs} + 5,244 \text{ lbs}] \\ &= 36,660 \text{ lbs} - [-4,594 \text{ lbs}] \\ &= 41,254 \text{ lbs} \downarrow \end{aligned}$$

4



## 4

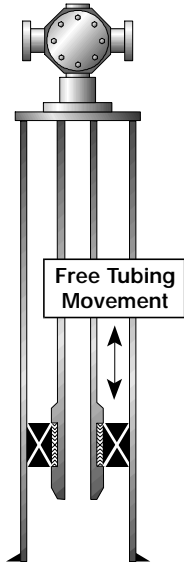

Figure 4.4

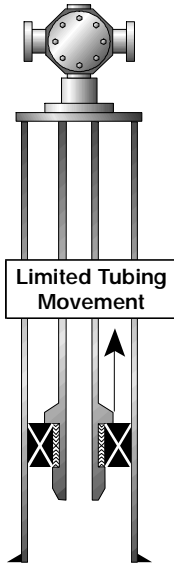

Figure 4.5

By definition, a positive force acts down, so the hook load is 41,254 lbs ↓, which is the same answer as in Example Problem 4-10.

When using equation 4-2, it is very important to keep track of the sign of the numbers.

### Seal Assemblies

All the hook-loads in the preceding section represent the weight indicator reading at the time of release. The predicted hook-load is important when releasing the seal assembly. Depending on the type of seal assembly, the predicted hook-load indicates what state the tubing string and packer are in.

With a “stung through” seal assembly (like the Camco Model ‘L’ Tubing Seal Nipple), the tubing is free to move in either direction. Figure 4.4 is a schematic illustration of a stung through seal assembly. With a stung through seal assembly, the predicted hook-load is the weight indicator reading at the time of release. So far, all examples have been stung through seal assemblies.

A “locator” or “landed” seal assembly (like a Camco Model ‘L’ Locator Seal Assembly), permits tubing movement in one direction only. A shoulder at the top of the seal assembly lands on the packer seal bore and prevents the tubing from moving down. Figure 4.5 illustrates a locator type seal assembly. The hook-load at the time of release may be lower than the predicted value. This indicates that tubing weight was slacked-off onto the packer. A locator seal assembly is retrieved by simply picking up the tubing string.

The third type of seal assembly, a “latch” type, is shown in Figure 4.6. A latch seal assembly (like a Camco Model ‘L’ Latch Seal Assembly), as the name implies, is rigidly connected to the packer and prevents tubing movement in either direction. The predicted hook-load represents the neutral point at the packer (i.e., no tension or compression in the tubing string at the packer). The hook-load at the time of release may be higher or lower than the predicted value. A higher hook-load than that calculated indicates tension was pulled through the packer. A lower hook-load than that calculated indicates tubing weight slacked-off onto the packer.

### Plugged Tubing

Plugged tubing represents a similar problem as that of unplugged tubing, except that along with knowing the tubing and annulus

pressures, the pressure below the packer must also be known. The pressure beneath the plug is either hydrostatic or formation pressure. When considering plugged tubing, there are only two situations that may arise.

## Tubing O.D. Smaller Than Packer Seal Bore

Figure 4.7 is a schematic illustration of a seal assembly where the packer bore is larger than the tubing O.D. The total force on the plug is the total tubing pressure times the area of the plug. Some of the force is canceled by tubing pressure acting up at the tubing-seal assembly connection ( $F_4$  in Figure 4.7). The net force the tubing pressure exerts on the plug ( $F_1$ ) is equal to the total tubing pressure times the tubing I.D. area ( $A_i$ ) and will increase the hook-load. Annulus pressure acting on the difference between the packer seal bore area ( $A_p$ ) and the tubing O.D. results in a downward force ( $F_2$ ) equal to the difference in area times the total annulus pressure at the packer ( $P_o$ ). The force ' $F_3$ ' is equal to the pressure below the plug ( $P_{trap}$ ) times the packer seal bore area ( $A_p$ ) and acts upward to reduce the hook load.

## Tubing O.D. Larger Than Packer Seal Bore

Figure 4.8 shows the forces acting on a seal assembly in which the tubing O.D. is larger than the packer seal bore. Tubing pressure will act on the plug and the tubing-seal assembly connection, producing a force ( $F_1$ ) equal to the total tubing pressure at the plug ( $P_i$ ) times the tubing I.D. area ( $A_i$ ). ' $F_1$ ' acts down and will increase the hook-load. Annulus pressure will produce an upward acting force ( $F_2$ ) equal to the total annulus pressure at the packer, times the difference between the tubing O.D. area ( $A_o$ ) and the packer seal bore area ( $A_p$ ). Finally, a force ( $F_3$ ) acts upward to decrease the hook-load equal to the pressure below the plug ( $P_{trap}$ ) times the packer seal bore area ( $A_p$ ).

A step by step procedure to determine the hook-load necessary to achieve a neutral point at the packer for the condition of plugged tubing follows:

### Tubing:

1. Calculate the total tubing pressure at the plug ( $P_i$ ). Total pressure is hydrostatic plus applied.
2. Find the inside area of the tubing ( $A_i$ ).

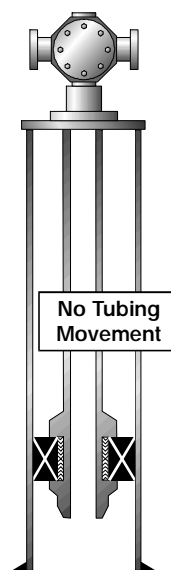

Figure 4.6

4

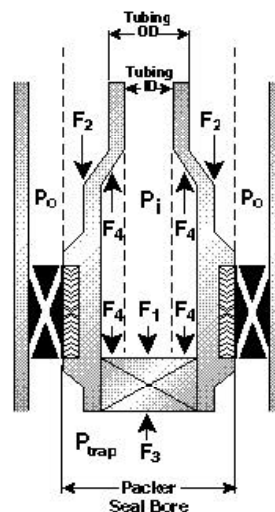

Figure 4.7

## 4

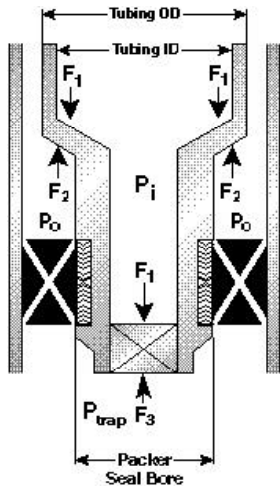

Figure 4.8

- The force 'F<sub>1</sub>' is equal to the total tubing pressure (P<sub>i</sub> in Step 1) times the tubing I.D. area (A<sub>i</sub> in Step 2). 'F<sub>1</sub>' will always act downward with the same magnitude regardless of the tubing size.

**Annulus:**

- Calculate the total annulus pressure at the packer (P<sub>o</sub>). Total pressure is hydrostatic plus applied.
- Calculate the difference between the packer seal bore area (A<sub>p</sub>) and the tubing O.D. area (A<sub>o</sub>). If the packer seal bore is larger than the tubing O.D., the force 'F<sub>2</sub>' will act down. If the tubing O.D. is larger, 'F<sub>2</sub>' acts upward.
- Calculate the force 'F<sub>2</sub>' by multiplying the total annulus pressure at the packer (P<sub>o</sub> in Step 4) with the difference in areas (Step 5).

**Plug:**

- Estimate the pressure trapped under the plug (P<sub>trap</sub>). It is either the formation pressure or the hydrostatic pressure at the plug when the tubing was plugged.
- Calculate the force 'F<sub>3</sub>' by multiplying the pressure below the plug (P<sub>trap</sub> in Step 7) by the packer seal bore area (A<sub>p</sub>). 'F<sub>3</sub>' will always act up with this magnitude, reducing the hook load.

**Tubing Weight:**

- Calculate the tubing weight in air (W<sub>t</sub>).

**Hook-Load:**

- Calculate the hook-load (W<sub>hl</sub>). The hook-load is the vector sum of the tubing weight and the buoyancy forces.

$$W_{hl} = W_t + F_1 + F_2 + F_3 \tag{4-3}$$

Remember to keep track of the sign of all the forces. 'W<sub>t</sub>' and 'F<sub>1</sub>' will always down and are positive (+). 'F<sub>2</sub>' may act either up or down depending on the size of the packer seal bore and tubing. If 'F<sub>2</sub>' acts down it is positive (+). If 'F<sub>2</sub>' acts up it is negative (-). 'F<sub>3</sub>' always acts up and is negative (-).

## Example Problem 4-14:

A blanking plug is stuck in the tail pipe of a latch type seal assembly. If the seal assembly requires 5,000 lbs tension to release, what is the required hook-load?

Well Data:

Packer Depth =	7,200 ft
Tubing Size =	2 <sup>3</sup> / <sub>8</sub> " 4.7 lbs/ft
Packer Seal Bore =	4.000"
Annulus Fluid =	9.0 lbs/gal water
Tubing Fluid =	44° API Oil
Pressure Below Plug =	2,200 psi

No applied pressure

Both the tubing and annulus are full.

Solution:

From the Engineering Tables:

Tubing Fluid Gradient, (fg <sub>t</sub> ) =	.350 psi/ft
Annulus Fluid Gradient, (fg <sub>a</sub> ) =	.468 psi/ft
Tubing I.D. Area, (A <sub>i</sub> ) =	3.126 in <sup>2</sup>
Tubing O.D. Area, (A <sub>o</sub> ) =	4.430 in <sup>2</sup>
Packer Seal Bore Area, (A <sub>p</sub> ) =	12.566 in <sup>2</sup>

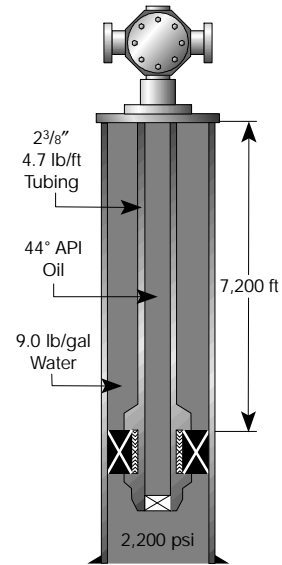

Problem 4-14

4

## 4

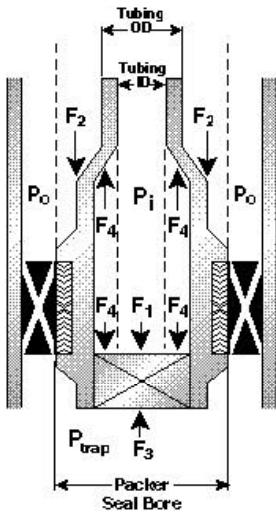

Problem 4-14

Tubing Calculations:

1. Tubing Pressure at the plug ( $P_i$ ).

$$\begin{aligned} P_i &= fg_i \times h \\ &= .350 \text{ psi/ft} \times 7,200 \text{ ft} \\ &= 2,520 \text{ psi} \end{aligned}$$

2. Tubing I.D. area ( $A_i$ ) = 3.126 in<sup>2</sup>

3. Force ' $F_1$ ':

$$\begin{aligned} F_1 &= P_i \times A_i \\ &= 2,520 \text{ psi} \times 3.126 \text{ in}^2 \\ &= 7,878 \text{ lbs} \downarrow \end{aligned}$$

Annulus Calculations:

4. Annulus Pressure at the packer ( $P_o$ ).

$$\begin{aligned} P_o &= fg_o \times h \\ &= .468 \text{ psi/ft} \times 7,200 \text{ ft} \\ &= 3,370 \text{ psi} \end{aligned}$$

5. Difference between packer seal bore area and tubing O.D. area ( $A_2$ ).

$$\begin{aligned} A_2 &= A_p - A_o \\ &= 12.566 \text{ in}^2 - 4.430 \text{ in}^2 \\ &= 8.136 \text{ in}^2 \end{aligned}$$

6. Force ' $F_2$ ':

$$\begin{aligned} F_2 &= P_o \times A_2 \\ &= 3,370 \text{ psi} \times 8.136 \text{ in}^2 \\ &= 27,418 \text{ lbs} \downarrow \end{aligned}$$

7. Pressure Below Plug ( $P_{\text{trap}}$ ) = 2,200 psi

8. Force ' $F_3$ '.

$$\begin{aligned} F_3 &= P_{\text{trap}} \times A_p \\ &= 2,200 \text{ psi} \times 12.566 \text{ in}^2 \\ &= 27,645 \text{ lbs } \uparrow \end{aligned}$$

9. Tubing String Weight ( $W_t$ ).

$$\begin{aligned} W_t &= \omega \times L \\ &= 4.7 \text{ lbs/ft} \times 7,200 \text{ ft} \\ &= 33,840 \text{ lbs } \downarrow \end{aligned}$$

10. Hook-Load ( $W_{\text{hl}}$ ).

$$\begin{aligned} W_{\text{hl}} &= W_t + F_1 + F_2 + F_3 + \text{Release Tension} \\ &= 33,840 \text{ lbs } \downarrow + 7,878 \text{ lbs } \downarrow + 27,418 \text{ lbs } \downarrow \\ &\quad + (-27,645 \text{ lbs } \uparrow) + 5,000 \text{ lbs } \downarrow \\ &= 46,491 \text{ lbs } \downarrow \end{aligned}$$

The hook load to release the seal assembly is 46,491 lbs.

## General Hook Load Calculations For Plugged Tubing

As with unplugged tubing, the step by step procedures outlined in the previous section may be summarized in a single equation. The formula is valid regardless of the tubing or packer seal bore size. The general formula for the hook-load of plugged tubing is:

$$\text{Hook-Load}_{pt} = \text{Tubing Weight} - \text{Buoyancy Forces} \quad (4-4)$$

or

$$W_{pt} = \omega \times L - [P_o(A_o - A_p) - P_i(A_i) + P_{\text{trap}}(A_p)] \quad (4-5)$$

## 4

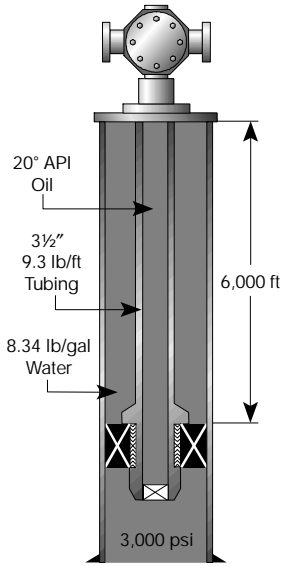

where:

- $A_i$  = tubing I.D. area (in<sup>2</sup>)
- $A_o$  = tubing O.D. area (in<sup>2</sup>)
- $A_p$  = packer seal bore area (in<sup>2</sup>)
- $L$  = total length of tubing (ft)
- $P_i$  = total tubing pressure @ packer (psi)
- $P_o$  = total annulus pressure @ packer (psi)
- $P_{trap}$  = pressure below tubing plug (psi)
- $W_{pt}$  = hook-load for plugged tubing (lbs)
- $\omega$  = linear weight per foot of tubing (lbs/ft)

**Example Problem 4-15:**

What is the hook load to release a locator type seal assembly installed under the following conditions?

Well Data:

- Packer Depth = 6,000 ft
- Tubing Size = 3 1/2" 9.3 lbs/ft
- Packer Seal Bore = 2.500"
- Annulus Fluid = 8.34 lbs/gal water
- Tubing Fluid = 20° API Oil
- Pressure Below Plug = 3,000 psi

No applied pressure.

Both the tubing and annulus are full.

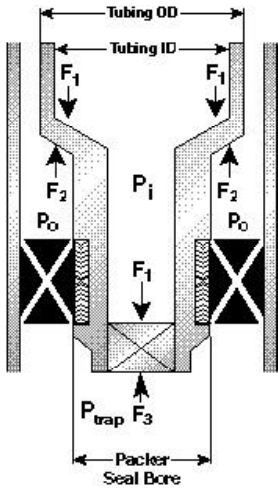

Problem 4-15

# Schlumberger

Solution:

From the Engineering Tables:

$$\text{Tubing Fluid Gradient, } (fg_i) = .404 \text{ psi/ft}$$

$$\text{Annulus Fluid Gradient, } (fg_o) = .433 \text{ psi/ft}$$

$$\text{Tubing I.D. Area, } (A_i) = 7.031 \text{ in}^2$$

$$\text{Tubing O.D. Area, } (A_o) = 9.621 \text{ in}^2$$

$$\text{Packer Seal Bore Area, } (A_p) = 4.909 \text{ in}^2$$

Tubing Calculations.

1. Tubing Pressure at the plug ( $P_i$ ).

$$\begin{aligned} P_i &= fg_i \times h \\ &= .404 \text{ psi/ft} \times 6,000 \text{ ft} \\ &= 2,424 \text{ psi} \end{aligned}$$

Annulus Calculations:

2. Annulus Pressure at the packer ( $P_o$ ).

$$\begin{aligned} P_o &= fg_o \times h \\ &= .433 \text{ psi/ft} \times 6,000 \text{ ft} \\ &= 2,598 \text{ psi} \end{aligned}$$

3. Hook Load.

$$\begin{aligned} W_{pt} &= \omega \times L - [P_o (A_o - A_p) - P_i (A_i) + P_{\text{trap}} (A_p)] \\ &= (9.3 \text{ lbs/ft} \times 6,000 \text{ ft}) \\ &\quad - [2,598 \text{ psi} (9.621 \text{ in}^2 - 4.909 \text{ in}^2) \\ &\quad - 2,424 \text{ psi} (7.031 \text{ in}^2) + 3,000 \text{ psi} (4.909 \text{ in}^2)] \\ &= 55,800 \text{ lbs} - [2,598 \text{ psi} (4.712 \text{ in}^2) - 17,043 \text{ lbs} \\ &\quad + 14,727 \text{ lbs}] \end{aligned}$$

4



$$\begin{aligned} &= 55,800 \text{ lbs} - [12,242 \text{ lbs} - 17,043 \text{ lbs} + 14,727 \text{ lbs}] \\ &= 55,800 \text{ lbs} - 12,241 \text{ lbs} + 17,043 \text{ lbs} - 14,727 \text{ lbs} \\ &= 45,875 \text{ lbs} \downarrow \end{aligned}$$

Since the answer is positive the force acts down.

## Tapered Tubing Strings

If the installation uses a tapered tubing string, the forces at the tapers have to be accounted for. Depending on the pressures and configuration of the tapers, the forces will either increase or decrease the hook load. Tapers were discussed in Chapter 3.

Section 1 describes the basic principles for evaluating a packer installation. The well conditions were assumed to be static, i.e. they did not change. During any service operation or when producing, the well conditions will change from those in which the packer was installed. The most important aspect of evaluating an installation is the effects of any changes that take place after the tool is installed. Varying pressure, temperature and applied forces from the surface cause force and length changes. Knowing the magnitude of these changes aids in proper tool selection and installation. This chapter investigates the effects of changing well conditions to an installed packer and the tubing string.

Changing the tubing pressure, annulus pressure or the well temperature results in either a force on the end of the tubing string or a change in the length of the tubing string. If the tubing is not free to move, forces are generated on the packer and the wellhead. If the tubing is free to move, it will either shorten or elongate. There are five basic effects which can occur if the well conditions change. Each effect can be analyzed separately and then combined with the others to get the total effect. They are:

1. Piston Effect
2. Ballooning
3. Buckling
4. Temperature Effect
5. Applied Forces

The piston effect, buckling and ballooning are all a result of pressure changes. The temperature effect and any applied forces are independent of the well pressure. Each effect is considered individually and then combined with the others to achieve a total effect. The end result could be a force or a length change. The total effect depends on the type of tubing-packer connection.

In Chapter 4 the different types of seal assemblies were considered. The three possibilities are:

1. Stung Through Packer (free motion)
2. Located or Landed Tubing (limited motion)
3. Latched Tubing (no motion)

If the end result of all the effects acts in a direction in which the packer allows motion, then the tubing length changes are determined. If the total effect is in a direction in which the packer does not allow motion, then generated forces are found.

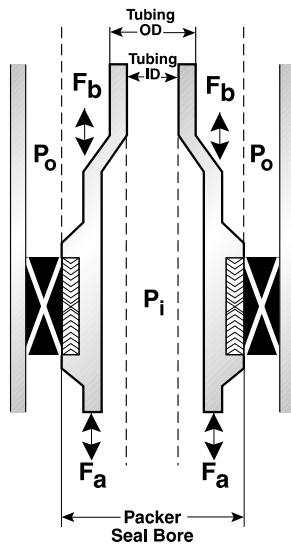

Figure 5.1

5

## PISTON EFFECT

The preceding chapters explained how different pressures acting on individual areas can create forces. This phenomenon is called “piston effect”. When a packer is set downhole or a seal assembly is stung into a packer, the pressure in the tubing and annulus is equal. If either the tubing or annulus pressure subsequently changes, a differential pressure exists and generates a force on one or more areas. The piston effect only occurs at the packer and is also called an end area effect. If the tubing is free to move in relation to the packer, the piston effect causes a length change. If the tubing is anchored to the packer, the piston effect generates a force on the packer.

When running a packer into a well, the buoyancy force due to hydrostatic pressure acting on the tubing end area (see Chapter 4) causes the tubing string to shorten and reduces the hook load at the surface. Because the packer is part of the “work string”, the buoyancy forces do not affect the packer-tubing relationship. Figure 5.1 is an illustration of a simplified packer showing the areas where pressure acts. Tubing pressure ( $P_i$ ) will act on the difference between the packer seal bore ( $A_p$ ) and the tubing I.D. area ( $A_i$ ) creating force ‘ $F_a$ ’. Annulus pressure ( $P_o$ ) acts on the difference between the packer seal bore area ( $A_p$ ) and the tubing O.D. area ( $A_o$ ) creating force ‘ $F_b$ ’. These forces are always present. When the packer is set, ‘ $F_a$ ’ and ‘ $F_b$ ’ are equal and there is no net force on the packer (other than the setting force). After setting the packer, it is no longer free to move and **any pressure changes will cause a change** in ‘ $F_a$ ’ or ‘ $F_b$ ’ in the manner described in Chapter 4.

### Piston Effect Calculations:

When determining the force due to the piston effect, it is **pressure change** rather than absolute pressure that is important. Accordingly, the initial and final well conditions must be known. The initial conditions are those that existed when the packer was set, or when the seal assembly was stung into the packer. The final conditions are those expected during well servicing or production. To calculate the force due to piston effect, use the following step by step procedure:

# Schlumberger

## Tubing Calculations:

1. Calculate the initial tubing pressure at the packer using the following formula:

$$(P_i)_{\text{initial}} = (P_{\text{iapp}})_{\text{initial}} + (P_{\text{ihydro}})_{\text{initial}} \quad (5-1)$$

2. Calculate the final tubing pressure at the packer using the following formula:

$$(P_i)_{\text{final}} = (P_{\text{iapp}})_{\text{final}} + (P_{\text{ihydro}})_{\text{final}} \quad (5-2)$$

3. Calculate the change in tubing pressure at the packer as follows:

$$\Delta P_i = (P_i)_{\text{final}} - (P_i)_{\text{initial}} \quad (5-3)$$

Results can be either positive (increase in pressure) or negative (decrease in pressure).

## Annulus Calculations:

4. Calculate the initial annulus pressure at the packer using the following formula:

$$(P_o)_{\text{initial}} = (P_{\text{oapp}})_{\text{initial}} + (P_{\text{ohydro}})_{\text{initial}} \quad (5-4)$$

5. Calculate the final annulus pressure at the packer using the following formula:

$$(P_o)_{\text{final}} = (P_{\text{oapp}})_{\text{final}} + (P_{\text{ohydro}})_{\text{final}} \quad (5-5)$$

6. Calculate the change in annulus pressure at the packer using the following formula:

$$\Delta P_o = (P_o)_{\text{final}} - (P_o)_{\text{initial}} \quad (5-6)$$

7. If the tubing is not free to move, calculate the piston force using:

$$F_1 = \Delta P_o (A_p - A_o) - \Delta P_i (A_p - A_i) \quad (5-7)$$

If the answer is negative, the force is a tension on the packer.  
If the answer is positive, the force is a compression on the packer.

8. If the tubing is free to move, calculate the piston length change using:

$$\Delta L_1 = \frac{[\Delta P_o(A_p - A_o) - \Delta P_i(A_p - A_i)] L}{E A_s} \quad (5-8)$$

The term inside the brackets is the force due to the piston effect ( $F_1$ ). If the force is already known, the length change equation simplifies to:

$$\Delta L_1 = \frac{F_1 L}{E A_s} \quad (5-9)$$

If  $\Delta L_1$  is negative, the tubing string shortens. If  $\Delta L_1$  is positive, the tubing string elongates.

where:

$A_i$	= tubing I.D. area (in <sup>2</sup> )
$A_o$	= tubing O.D. area (in <sup>2</sup> )
$A_p$	= packer seal bore area (in <sup>2</sup> )
$A_s$	= tubing cross-sectional area (in <sup>2</sup> )
$E$	= modulus of elasticity of steel (30,000,000)
$F_1$	= force due to piston effect (lbs)
$L$	= length of tubing (in.)
$(P_i)_{initial}$	= initial tubing pressure @ packer (psi)
$(P_i)_{final}$	= final tubing pressure @ packer (psi)
$(P_{iapp})_{initial}$	= initial applied tubing pressure (psi)
$(P_{ihydro})_{initial}$	= initial hydrostatic tubing pressure @ packer (psi)
$(P_{iapp})_{final}$	= final applied tubing pressure (psi)
$(P_{ihydro})_{final}$	= final hydrostatic tubing pressure @ packer (psi)
$(P_o)_{initial}$	= initial annulus pressure @ packer (psi)
$(P_o)_{final}$	= final annulus pressure @ packer (psi)
$(P_{oapp})_{initial}$	= initial applied annulus pressure (psi)
$(P_{ohydro})_{initial}$	= initial hydrostatic annulus pressure @ packer (psi)
$(P_{oapp})_{final}$	= final applied annulus pressure (psi)
$(P_{ohydro})_{final}$	= final hydrostatic annulus pressure @ packer (psi)
$\Delta L_1$	= length change due to piston effect (in.)
$\Delta P_i$	= change in tubing pressure @ packer (psi)
$\Delta P_o$	= change in annulus pressure @ packer (psi)

The length change due to the piston effect ( $\Delta L_1$ ) can also be found using the "Tubing Stretch" charts in Appendix F. Use the piston force ( $F_1$ ) in place of "Applied Force".

# Schlumberger

## Example Problem 5-1:

A 7" Camco Model 'Omegatrieve-M' Retrievable Packer (3.250 in seal bore) was set on wireline at 7,500 ft in 7" 26 lb/ft casing. The seal assembly was run on 2 7/8" EUE 6.5 lb/ft, L-80 tubing. When the seal assembly was run into the well, the well fluid was encountered at 4,340 ft. The well fluid was 9.0 lb/gal brine. After stinging into the packer bore, 5,000 lbs of tubing weight was slacked-off onto the packer. The tubing and annulus were then both filled with 9.0 lb/gal brine. After filling the tubing and annulus, 2,500 psi was applied to the tubing to inject the brine into the formation. The initial surface temperature was 71°F and the initial bottom hole temperature was 175°F. The injected brine was at 68°F.

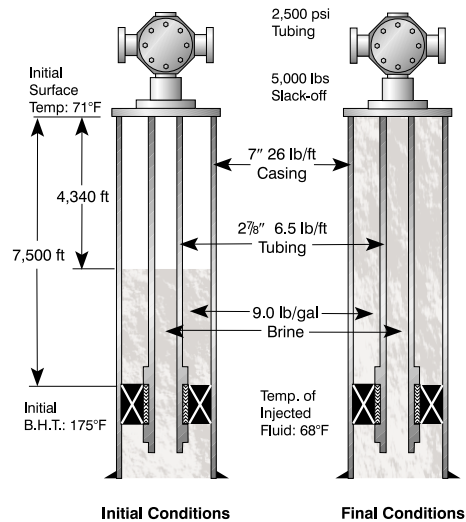

1. If the seal assembly was a Camco Model 'L' Latch Seal Assembly (tubing not free to move), what is the piston force on the packer during injection?

2. If the seal assembly was a Camco Model 'L' Locator Seal Assembly (tubing free to move up), by how much would the tubing length change due to the piston effect?

## Problem 5-1

5

Solution:

From the engineering tables:

Tubing I.D. Area ( $A_i$ ) = 4.680 in<sup>2</sup>

Tubing O.D. Area ( $A_o$ ) = 6.492 in<sup>2</sup>

Packer Seal Bore Area ( $A_p$ ) = 8.296 in<sup>2</sup>

Tubing Cross-Sectional Area ( $A_s$ ) = 1.812 in<sup>2</sup>

Well Fluid Gradient ( $f_g$ ) = .467 psi/ft

1. Piston force ( $F_1$ ) if tubing is free to move (landed seal assembly).

### Tubing Calculations:

1. Initial Tubing Pressure @ Packer ( $P_i$ )<sub>initial</sub>:

Initial Tubing Hydrostatic Pressure @ Packer, ( $P_{i\text{hydro}}$ )<sub>initial</sub>:

$$= f_g \times h_{\text{initial}}$$

$$= .467 \text{ psi/ft} \times (7,500 \text{ ft} - 4,340 \text{ ft})$$

$$= 1,476 \text{ psi}$$

Initial Applied Tubing Pressure,  $(P_{iapp})_{initial} = 0$  psi

Initial Tubing Pressure @ Packer  $(P_i)_{initial}$ :

$$\begin{aligned} &= (P_{iapp})_{initial} + (P_{ihydro})_{initial} \\ &= 0\text{psi} + 1,476\text{ psi} \\ &= 1,476\text{ psi} \end{aligned}$$

2. Final Tubing Pressure @ Packer  $((P_{ihydro})_{final})$ :

Final Hydrostatic Tubing Pressure @ Packer  $((P_{ihydro})_{final})$ :

$$\begin{aligned} &= fg \times h_{final} \\ &= .467\text{ psi/ft} \times 7,500\text{ ft} \\ &= 3,503\text{ psi} \end{aligned}$$

Final Applied Tubing Pressure,  $(P_{iapp})_{final} = 2,500$  psi

Final Tubing Pressure @ Packer  $((P_i)_{final})$ :

$$\begin{aligned} &= (P_{iapp})_{final} + (P_{ihydro})_{final} \\ &= 2,500\text{ psi} + 3,503\text{ psi} \\ &= 6,003\text{ psi} \end{aligned}$$

3. Change in Tubing Pressure @ Packer  $(\Delta P_i)$ :

$$\begin{aligned} &= (P_i)_{final} - (P_i)_{initial} \\ &= 6,003\text{ psi} - 1,476\text{ psi} \\ &= 4,527\text{ psi} \end{aligned}$$

#### Annulus:

4. Initial Annulus Pressure @ Packer  $(\Delta P_o)$ .

Initial Annulus Hydrostatic Pressure,  $((P_{ohydro})_{initial})$ :

$$\begin{aligned} &= fg \times h_{initial} \\ &= .467\text{ psi/ft} \times (7,500\text{ ft} - 4,340\text{ ft}) \\ &= 1,476\text{ psi} \end{aligned}$$

# Schlumberger

Initial Applied Annulus Pressure,  $(P_{oapp})_{initial} = 0$  psi

Initial Annulus Pressure @ Packer  $((P_o)_{initial})$ :

$$\begin{aligned} &= (P_{oapp})_{initial} + (P_{hydro})_{initial} \\ &= 0 \text{ psi} + 1,476 \text{ psi} \\ &= 1,476 \text{ psi} \end{aligned}$$

5. Final Annulus Pressure @ Packer  $((P_o)_{final})$ :

Final Annulus Hydrostatic Pressure @ Packer  $((P_{ohydro})_{final})$ :

$$\begin{aligned} &= fg \times h_{final} \\ &= .467 \text{ psi/ft} \times 7,500 \text{ ft} \\ &= 3,503 \text{ psi} \end{aligned}$$

Final Applied Annulus Pressure,  $(P_{oapp})_{final} = 0$  psi

Final Annulus Pressure @ Packer  $((P_o)_{final})$ :

$$\begin{aligned} &= (P_{oapp})_{final} + (P_{hydro})_{final} \\ &= 0 \text{ psi} + 3,503 \text{ psi} \\ &= 3,503 \text{ psi} \end{aligned}$$

6. Change in Annulus Pressure @ Packer  $(\Delta P_o)$ :

$$\begin{aligned} &= (P_o)_{final} - (P_o)_{initial} \\ &= 3,503 \text{ psi} - 1,476 \text{ psi} \\ &= 2,027 \text{ psi} \end{aligned}$$

7. Piston Force  $(F_1)$ :

$$\begin{aligned} F_1 &= \Delta P_o (A_p - A_o) - \Delta P_i (A_p - A_i) \\ &= 2,027 \text{ psi} (8.296 \text{ in}^2 - 6.492 \text{ in}^2) \\ &\quad - 4,527 \text{ psi} (8.296 \text{ in}^2 - 4.680 \text{ in}^2) \\ &= 2,027 \text{ psi} (1.804 \text{ in}^2) - 4,527 \text{ psi} (3.616 \text{ in}^2) \\ &= 3,657 \text{ lbs} - 16,370 \text{ lbs} \\ &= -12,713 \text{ lbs} \uparrow \end{aligned}$$

5



If the tubing is not free to move (latch seal assembly), there is a force of 12,713 lbs tension on the packer.

**8. Length Change Due to Piston Effect ( $\Delta L_1$ ):**

The piston effect length change can be read directly from the “Tubing Stretch” chart in Appendix F, using -12,713 lbs  $\uparrow$  as the “Pull on Tubing - Pounds”. When using the chart, the following calculations may be omitted. They are shown here for demonstration.

$$F_1 = -12,713 \text{ lbs } \uparrow$$

Tubing Length in Inches:

$$L = 7,500 \text{ ft} \times 12 \text{ in./ft} = 90,000 \text{ in.}$$

Piston Effect Length Change ( $\Delta L_1$ ):

$$\begin{aligned} \Delta L_1 &= \frac{F_1 L}{E A_s} \\ &= \frac{-12,713 \text{ lbs} \times 90,000 \text{ in.}}{30,000,000 \times 1.812 \text{ in}^2} \\ &= -21.05 \text{ in. } \uparrow \end{aligned}$$

If the tubing is free to move, it will shorten by 21.05”.

**5**

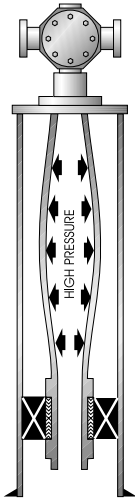

**Ballooning**

**Figure 5.2**

**BALLOONING**

Ballooning is a result of higher pressure inside the tubing string than outside. The pressure differential creates stresses which try to burst the tubing string. The burst stress causes the tubing to swell as shown in Figure 5.2. As the tubing swells, its length becomes shorter, if free to move. If the tubing is anchored, the swelling generates a tensile force on the packer.

If the pressure in the annulus is higher than that in the tubing, the pressure differential creates stresses which tend to collapse the tubing (see Figure 5.3). If free to move, the tubing length will increase as the tubing string collapses. If the tubing is anchored, the stresses in the tubing generate a compressive force on the packer. A lengthening of the tubing string due to collapse stresses is called reverse ballooning.

The ballooning effect is directly related to the area which the pressures act on. The outside area of a tubing string is larger than

# Schlumberger

the inside area, so a change in the annulus pressure has a greater effect than a corresponding change in the tubing pressure. Therefore, pressure changes in the tubing and annulus must be treated separately to determine the ballooning effect.

Unlike the piston effect, ballooning is not localized but occurs throughout the entire length of the tubing string. Hence, the calculations for ballooning are based on the *average pressure change* in the tubing and annulus. The average pressure is half the sum of the surface (applied) and bottom hole pressures. Because the bottom hole pressure is the sum of the surface and hydrostatic pressure, a change in the surface pressure has double the effect of changing the fluid gradient.

Since both the average annulus and tubing pressures may change during well servicing or production, ballooning and reverse ballooning effects are calculated together. Like the piston effect, ballooning causes either a force or a length change depending on the tubing-packer connection.

## Ballooning Effect Calculations:

Use the following step by step procedure to calculate the ballooning effect:

### Tubing Calculations:

1. Calculate the initial average tubing pressure  $((P_{ia})_{initial})$  using the following formula:

$$(P_{ia})_{initial} = \frac{(P_{iapp})_{initial} + (P_i)_{initial}}{2} \quad (5-10)$$

The initial tubing pressure at the packer  $((P_i)_{initial})$  is found using equation (5-1).

2. Calculate the final average tubing pressure  $((P_{ia})_{final})$  using the following formula:

$$(P_{ia})_{final} = \frac{(P_{iapp})_{final} + (P_i)_{final}}{2} \quad (5-11)$$

The final tubing pressure at the packer  $((P_i)_{final})$  is found using equation (5-2).

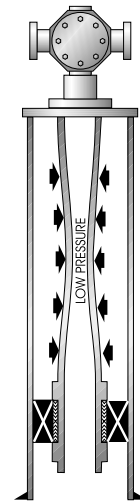

Reverse Ballooning

Figure 5.3

5

3. Calculate the change in average tubing pressure ( $\Delta P_{ia}$ ) using the following formula:

$$\Delta P_{ia} = (P_{ia})_{final} - (P_{ia})_{initial} \quad (5-12)$$

**Annulus Calculations:**

4. Calculate the initial average annulus pressure ( $(P_{oa})_{initial}$ ) using the following formula:

$$(P_{oa})_{initial} = \frac{(P_{oapp})_{initial} + (P_o)_{initial}}{2} \quad (5-13)$$

The initial annulus pressure at the packer is found using equation (5-4).

5. Calculate the final average annulus pressure ( $(P_{oa})_{final}$ ) using the following formula:

$$(P_{oa})_{final} = \frac{(P_{oapp})_{final} + (P_o)_{final}}{2} \quad (5-14)$$

The final annulus pressure at the packer ( $(P_o)_{final}$ ) is found using equation (5-5).

6. Calculate the change in average annulus pressure ( $\Delta P_{oa}$ ) using the following formula:

$$\Delta P_{oa} = (P_{oa})_{final} - (P_{oa})_{initial} \quad (5-15)$$

7. If the tubing is not free to move, calculate the ballooning force ( $F_2$ ) as follows:

$$F_2 = .6 [(\Delta P_{oa} A_o) - (\Delta P_{ia} A_i)] \quad (5-16)$$

If the answer is negative, the force is a tension on the packer. If the answer is positive the force is a compression on the packer. Once the average pressure change is found, the ballooning force can be found using the "Ballooning Force" charts in Appendix E.

8. If the tubing is free to move, calculate the length change ( $\Delta L_2$ ) with the following formula:

$$\Delta L_2 = \frac{F_2 L}{EA_s} \quad (5-17)$$

# Schlumberger

Alternatively, if the ballooning force ( $F_2$ ) is known, the “Slack-Off” or “Tubing Stretch” charts can be used to find the length change.

If the answer is negative, the tubing string shortens. If the answer is positive the tubing string elongates.

where:

$A_i$	= tubing I.D. area (in <sup>2</sup> )
$A_o$	= tubing O.D. area (in <sup>2</sup> )
$A_s$	= tubing wall area (in <sup>2</sup> )
$E$	= modulus of elasticity of steel (30,000,000 psi)
$F_2$	= ballooning force (lbs)
$L$	= length of tubing (in.)
$(P_i)_{initial}$	= initial tubing pressure @ packer (psi)
$(P_i)_{final}$	= final tubing pressure @ packer (psi)
$(P_{ia})_{initial}$	= average initial tubing pressure (psi)
$(P_{ia})_{final}$	= average final tubing pressure (psi)
$(P_o)_{initial}$	= initial annulus pressure @ packer (psi)
$(P_o)_{final}$	= final annulus pressure @ packer (psi)
$(P_{oa})_{initial}$	= average initial annulus pressure (psi)
$(P_{oa})_{final}$	= average final annulus pressure (psi)
$\Delta L_2$	= length change due to ballooning (in.)
$\Delta P_{ia}$	= change in average tubing pressure (psi)
$\Delta P_{oa}$	= change in average annulus pressure (psi)

## Example Problem 5-2:

For the conditions in example problem 5-1 determine the following:

1. If the seal assembly was a Camco Model ‘L’ Latch Seal Assembly (tubing not free to move), what is the ballooning force on the packer during injection?
2. If the seal assembly was a Camco Model ‘L’ Locator Seal Assembly (tubing free to move up), by how much would the tubing length change due to the ballooning effect?

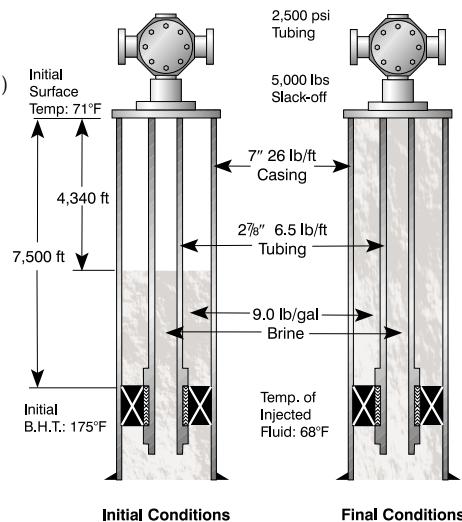

5

## Problem 5-2

Solution:

From the engineering tables:

$$\text{Tubing I.D. Area (A}_i\text{)} = 4.680 \text{ in}^2$$

$$\text{Tubing O.D. Area (A}_o\text{)} = 6.492 \text{ in}^2$$

$$\text{Ratio of Tubing O.D. to I.D. (R)} = 1.178$$

$$\text{Well Fluid Gradient (fg)} = .467 \text{ psi/ft}$$

### Tubing Calculations:

1. Initial Average Tubing Pressure  $((P_{ia})_{\text{initial}})$ :

$$\text{Initial Applied Tubing Pressure } ((P_{iapp})_{\text{initial}}) = 0 \text{ psi}$$

$$\text{Initial Tubing Hydrostatic Pressure } ((P_{ihydro})_{\text{initial}}):$$

$$= fg \times h_{\text{initial}}$$

$$= .467 \text{ psi/ft} \times (7,500 \text{ ft} - 4,340 \text{ ft})$$

$$= 1,476 \text{ psi}$$

$$\text{Initial Total Tubing Pressure @ Packer } ((P_i)_{\text{initial}}):$$

$$= (P_{iapp})_{\text{app}} + (P_{ihydro})_{\text{initial}}$$

$$= 0 \text{ psi} + 1,476 \text{ psi}$$

$$= 1,476 \text{ psi}$$

$$\text{Initial Average Tubing Pressure } ((P_{ia})_{\text{initial}}):$$

$$= \frac{(P_{iapp})_{\text{app}} + (P_i)_{\text{initial}}}{2}$$

$$= \frac{0 + 1,476 \text{ psi}}{2}$$

$$= 738 \text{ psi}$$

2. Final Average Tubing Pressure  $((P_{ia})_{\text{final}})$ :

$$\text{Final Applied Tubing Pressure } ((P_{iapp})_{\text{final}}) = 2,500 \text{ psi}$$

$$\text{Final Tubing Hydrostatic Pressure } ((P_{ihydro})_{\text{final}}):$$

$$= fg \times h_{\text{final}}$$

# Schlumberger

$$= .467 \text{ psi/ft} \times 7,500 \text{ ft}$$

$$= 3,503 \text{ psi}$$

Final Tubing Pressure @ Packer  $((P_i)_{\text{final}})$ :

$$= (P_{\text{iapp}})_{\text{final}} + (P_{\text{ihydro}})_{\text{final}}$$

$$= 2,500 \text{ psi} + 3,503 \text{ psi}$$

$$= 6,003 \text{ psi}$$

Final Average Tubing Pressure  $((P_{\text{ia}})_{\text{final}})$ :

$$= \frac{(P_{\text{iapp}}) + (P_{\text{i}})_{\text{initial}}}{2}$$

$$= \frac{2,500 \text{ psi} + 6,003 \text{ psi}}{2}$$

$$= 4,252 \text{ psi}$$

3. Change in Average Tubing Pressure  $(\Delta P_{\text{ia}})$ :

$$= (P_{\text{ia}})_{\text{final}} - (P_{\text{ia}})_{\text{initial}}$$

$$= 4,242 \text{ psi} - 738 \text{ psi}$$

$$= 3,516 \text{ psi}$$

## Annulus Calculations:

4. Initial Average Annulus Pressure  $((P_{\text{io}})_{\text{initial}})$ :

Initial Applied Annulus Pressure  $((P_{\text{oapp}})_{\text{initial}}) = 0 \text{ psi}$

Initial Annulus Hydrostatic Pressure  $((P_{\text{ohydro}})_{\text{initial}})$ :

$$= fg \times h_{\text{initial}}$$

$$= .467 \text{ psi/ft} \times (7,500 \text{ ft} - 4,340 \text{ ft})$$

$$= 1,476 \text{ psi}$$

Initial Annulus Pressure @ Packer ( $(P_o)_{initial}$ ):

$$\begin{aligned} &= (P_{oapp})_{initial} + (P_{ohydro})_{initial} \\ &= 0 \text{ psi} + 1,476 \text{ psi} \\ &= 1,476 \text{ psi} \end{aligned}$$

Initial Average Annulus Pressure ( $(P_{oa})_{initial}$ ):

$$\begin{aligned} &= \frac{(P_{oapp})_{initial} + (P_o)_{initial}}{2} \\ &= \frac{0 \text{ psi} + 1,476 \text{ psi}}{2} \\ &= 738 \text{ psi} \end{aligned}$$

5. Final Average Annulus Pressure ( $(P_{oa})_{final}$ ):

Final Applied Annulus Pressure ( $(P_{oapp})_{final}$ ) = 0 psi

Final Annulus Hydrostatic Pressure ( $(P_{ohydro})_{final}$ ):

$$\begin{aligned} &= fg \times h_{final} \\ &= .467 \text{ psi/ft} \times 7,500 \text{ ft} \\ &= 3,503 \text{ psi} \end{aligned}$$

Final Annulus Pressure @ Packer ( $(P_o)_{final}$ ):

$$\begin{aligned} &= (P_{oapp})_{final} + (P_{ohydro})_{final} \\ &= 0 \text{ psi} + 3,503 \text{ psi} \\ &= 3,503 \text{ psi} \end{aligned}$$

Final Average Annulus Pressure ( $(P_{oa})_{final}$ ):

$$\begin{aligned} &= \frac{(P_{oapp})_{final} + (P_o)_{final}}{2} \\ &= \frac{0 + 3,503 \text{ psi}}{2} \\ &= 1,752 \text{ psi} \end{aligned}$$

5

# Schlumberger

## 6. Change in Average Annulus Pressure ( $\Delta P_{oa}$ ):

$$\begin{aligned} &= (P_{oa})_{\text{final}} - (P_{oa})_{\text{initial}} \\ &= 1,752 \text{ psi} - 738 \text{ psi} \\ &= 1,014 \text{ psi} \end{aligned}$$

## 7. Ballooning Force ( $F_2$ ):

The ballooning force can be read directly from the “Ballooning Force” charts in Appendix E. When using the charts the calculations may be omitted. They are shown here for demonstration.

$$\begin{aligned} F_2 &= .6 [(\Delta P_{oa} A_o) - (\Delta P_{ia} A_i)] \\ &= .6 [(1,014 \text{ psi} \times 6.492 \text{ in}^2) - (3,514 \text{ psi} \times 4.680 \text{ in}^2)] \\ &= .6 [6,576 \text{ lbs} - 16,455 \text{ lbs}] \\ &= .6 [-9,863 \text{ lbs}] \\ &= -5,918 \text{ lbs} \uparrow \text{ (negative, so tension on packer)} \end{aligned}$$

## 8. Length Change ( $\Delta L_2$ ) Due to Ballooning Effect:

The ballooning effect length change can be read directly from the “Tubing Stretch” charts in Appendix F, using (-5,927 lbs  $\uparrow$ ) as the “Pull on Tubing - Pounds”. When using the chart, the following calculations may be omitted. They are shown here for demonstration.

$$\begin{aligned} A_s &= 1.812 \text{ in}^2 \\ \Delta L_2 &= \frac{F_2 L}{EA_s} \\ &= \frac{(-5,918 \text{ lbs})(90,000 \text{ in.})}{(30,000,000 \text{ psi})(1.812 \text{ in}^2)} \\ &= -9.80 \text{ in.} \uparrow \text{ (Tubing will shorten)} \end{aligned}$$

5



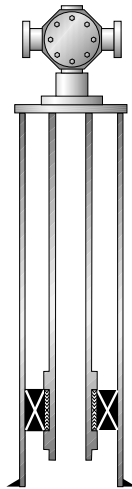

**Straight Tubing**

**Figure 5.4**

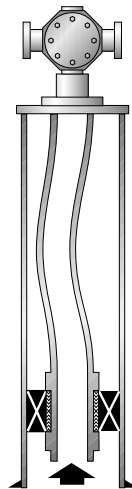

**Bowed Tubing**

**Figure 5.5**

## BUCKLING

The buckling effect is the most unusual and difficult to understand of all the effects. Buckled tubing is caused by two distinct force distributions. A compressive force on the end of the tubing string will cause it to buckle. Buckling is also caused by an uneven pressure distribution across the tubing wall.

Buckled tubing is bowed from its usually straight position (see Figure 5.4 and 5.5). If the compressive force is high enough, the tubing will continue to buckle until it contacts the casing wall. After contacting the casing, the tubing will begin to coil inside the casing in the form of a spring or helix (see Figure 5.6). So long as the buckling stresses in the tubing remain below the its yield strength, the tubing will return to its original shape once the buckling force is removed. If the bending stresses exceed the tubing's yield strength, it will remain permanently deformed.

There are several important facts about buckling that must be understood. Buckling is most severe at the bottom of the tubing string. There is a point, called the neutral point, above which no buckling occurs (see Figure 5.6). If the buckling is very severe, the neutral point may be above the wellhead, in which case the entire tubing string is buckled. Since a compressive force is necessary, buckling will only shorten the tubing string; buckling cannot cause an increase in length. Buckling due to pressure exerts a negligible force on a packer and is ignored as a force. If the annulus pressure is greater than the tubing pressure, no buckling will occur. Finally, a tubing string can buckle even if the tubing is in tension. The buckling is due to the uneven pressure distribution across the tubing wall.

An important consideration with buckling due to applied weight is the generated friction from the tubing contacting the casing wall. This friction will reduce the weight that reaches the packer. As more weight is slacked-off onto the packer, more tubing will contact the casing wall, increasing the friction. Eventually, the friction becomes great enough to support the excess weight of the tubing string, and no more weight reaches the packer. This effect is covered in more detail later in the chapter.

### Calculating Length Change Due to Buckling:

Since the force on a packer due to buckling is negligible, only the tubing length change needs to be found. If the final annulus pressure is greater than the final tubing pressure, there is no buck-

# Schlumberger

ling due to pressure. That is, there is no length change due to buckling. Use the following step by step procedure to calculate the length change due to buckling:

## Tubing Calculations:

1. Calculate the change in tubing pressure at the packer ( $\Delta P_i$ ) using:

$$\Delta P_i = (P_i)_{\text{final}} - (P_i)_{\text{initial}} \quad (5-3)$$

2. Determine the moment of inertia of the tubing ( $I$ ) in  $\text{in}^4$ . This is found in the engineering tables under "Tubing Dimensional Data" or by using the formula:

$$I = \frac{3.142}{64} [(Tbg. O.D.)^4 - (Tbg. I.D.)^4] \quad (5-17)$$

3. Determine the linear weight of the final fluid displaced in the tubing in  $\text{lbs/in}$  ( $W_i$ ). This is found in the "Tubing Weight Factors" Table in Appendix E or using:

$$W_i = A_i \times \omega_i (\text{lbs/gal}) \times \frac{1 \text{ gal}}{231 \text{ in}^3} \quad (5-18)$$

4. Determine the linear weight per *inch* of the tubing string ( $W_s$ ):

$$W_s = \omega (\text{lbs/ft}) \div 12 \text{ in./ft} \quad (5-19)$$

## Annulus Calculations:

5. Calculate the change in annulus pressure at the packer ( $\Delta P_o$ ) using:

$$\Delta P_o = (P_o)_{\text{final}} - (P_o)_{\text{initial}} \quad (5-6)$$

6. Determine the linear weight of the final fluid displaced in the annulus in  $\text{lbs/in}$ . ( $W_o$ ). This is found in Appendix E or by using:

$$W_o = A_o \times \omega_o (\text{lbs/gal}) \times \frac{1 \text{ gal}}{231 \text{ in}^3} \quad (5-20)$$

7. Determine the radial clearance between the tubing and casing ( $r$ ):

$$r = \frac{Csg. I.D. - Tbg. O.D.}{2} \quad (5-21)$$

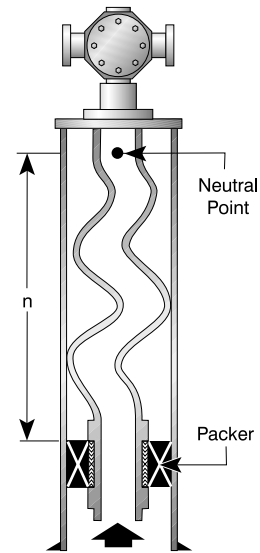

**Buckled Tubing**

**Figure 5.6**

**5**

8. Calculate the length change due to the buckling effect ( $\Delta L_3$ ):

$$\Delta L_3 = \left( \frac{(r)^2 (A_p)^2 (\Delta P_i - \Delta P_o)^2}{(-8) EI (W_s + W_i - W_o)} \right) \quad (5-22)$$

9. Calculate the height of the neutral point above the packer (n):

$$n = \frac{A_p [(P_i)_{\text{final}} - (P_o)_{\text{final}}]}{W_s + W_i - W_o} \quad (5-23)$$

10. If the height of the neutral point (n) is longer than the length of the tubing string (L), then a correction factor for the length change ( $\Delta L_3$ ) due to buckling is applied as follows:

$$\Delta L_3' = \Delta L_3 \times \left( \frac{L}{n} \right) \times \left[ 2 - \left( \frac{L}{n} \right) \right] \quad (5-24)$$

The corrected length change ( $\Delta L_3'$ ) is always less than the original length change ( $\Delta L_3$ ).

The terms in the above formulas:

$A_i$	= tubing I.D. area (in <sup>2</sup> )
$A_o$	= tubing O.D. area (in <sup>2</sup> )
$A_p$	= packer seal bore area (in <sup>2</sup> )
E	= modulus of elasticity of steel (30,000,000 psi)
I	= moment of inertia of tubing (in <sup>4</sup> )
L	= length of tubing (in.)
n	= height of neutral point above packer (in.)
$(P_i)_{\text{initial}}$	= initial total tubing pressure (psi)
$(P_i)_{\text{final}}$	= final tubing pressure @ packer (psi)
$(P_o)_{\text{initial}}$	= initial annulus pressure @ packer (psi)
$(P_o)_{\text{final}}$	= final annulus pressure @ packer (psi)
$\Delta L_3$	= buckling effect length change (in.)
$\Delta L_3'$	= corrected buckling effect length change (in.)
$\Delta P_i$	= change in tubing pressure @ packer (psi)
$\Delta P_o$	= change in annulus pressure @ packer (psi)
r	= radial clearance between tubing and casing
W	= linear weight of tubing (lb/ft)
$W_i$	= linear weight of tubing fluid (lb/in.)
$W_o$	= linear weight of annulus fluid (lbs/in.)
$W_s$	= linear weight of tubing string (lbs/in.)

# Schlumberger

**Note:** The above calculations do not solve for a buckling force, since buckling due to pressure exerts a negligible force on a packer.

### Example Problem 5-3:

For the conditions in example problem 5-1 determine: If the seal assembly was a Camco Model 'L' Locator Seal Assembly (tubing free to move up), by how much would the tubing length change due to the buckling effect?

Solution:

From the engineering tables:

Tubing I.D. Area ( $A_i$ )	=	4.680 in <sup>2</sup>
Tubing O.D. Area ( $A_o$ )	=	6.492 in <sup>2</sup>
Packer Seal Bore Area ( $A_p$ )	=	8.296 in <sup>2</sup>
Casing I.D.	=	6.184"
Tubing O.D.	=	2.875"
Tubing I.D.	=	2.441"
Well Fluid Gradient (fg)	=	.467 psi/ft

### Tubing Calculations:

1. Change in Tubing Pressure @ Packer ( $\Delta P_i$ ). (From Example Problem 5-1).

$$\Delta P_i = 4,527 \text{ psi}$$

2. Moment of Inertia of Tubing (I). This can be found in the "Tubing Dimensional Data" in Appendix A. The calculation is shown below for demonstration.

$$\begin{aligned}
 &= \frac{3.142}{64} [(Tbg. \text{ O.D.})^4 - (Tbg. \text{ I.D.})^4] \\
 &= \frac{3.142}{64} [(2.875 \text{ in.})^4 - (2.441 \text{ in.})^4] \\
 &= 1.611 \text{ in}^4
 \end{aligned}$$

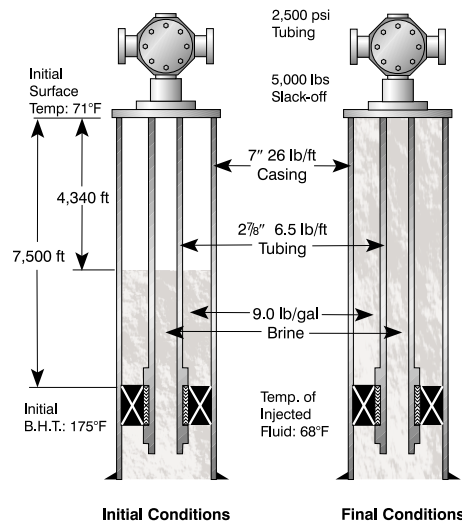

Problem 5-3

5

3. Linear Weight of Final Displaced Tubing Fluid in lbs/in ( $W_i$ ). This is found in Appendix E. The calculation is shown here for demonstration.

$$\begin{aligned} &= A_i \times \omega_i \times \frac{1 \text{ gal}}{231 \text{ in}^3} \\ &= 4.680 \text{ in}^2 \times 9.0 \text{ lb/gal} \times \frac{1 \text{ gal}}{231 \text{ in}^3} \\ &= .182 \text{ lb/in.} \end{aligned}$$

4. Linear Weight per inch of Tubing String ( $W_s$ ). This is found in the engineering tables in Appendix E. The calculation is shown here for demonstration.

$$\begin{aligned} &= \omega \div 12 \text{ in./ft} \\ &= 6.5 \text{ lb/ft} \div 12 \text{ in./ft} \\ &= .542 \text{ lb/in.} \end{aligned}$$

#### Annulus Calculations:

5. Change in Annulus Pressure at the Packer ( $\Delta P_o$ ). (From Example Problem 5-1.)

$$\Delta P_o = 2,027 \text{ psi}$$

6. Linear Weight of Final fluid Displaced in the Annulus ( $W_o$ ). This is found in the engineering tables in Appendix E. The calculation is shown for demonstration.

$$\begin{aligned} &= A_o \times \omega_o \times \frac{1 \text{ gal}}{231 \text{ in}^3} \\ &= 6.492 \text{ in}^2 \times 9.0 \text{ lb/gal} \times \frac{1 \text{ gal}}{231 \text{ in}^3} \\ &= .253 \text{ lb/in.} \end{aligned}$$

# Schlumberger

7. Radial Clearance Between Tubing and Casing (r):

$$\begin{aligned} &= \frac{\text{Csg. I.D.} - \text{Tbg. O.D.}}{2} \\ &= \frac{6.184 \text{ in.} - 2.875 \text{ in.}}{2} \\ &= 1.655 \text{ in.} \end{aligned}$$

8. Length Change Due to Buckling Effect ( $\Delta L_3$ ):

$$\begin{aligned} &= \frac{(r)^2(A_p)^2(\Delta P_i - \Delta P_o)^2}{(-8)EI(W_s + W_i - W_o)} \\ &= \frac{(1.655 \text{ in.})^2 (8.296 \text{ in.})^2 (4,527 \text{ psi} - 2,027 \text{ psi})^2}{(-8)(30,000,000 \text{ psi})(1.611 \text{ in}^4)(.542 + .182 - .253)} \\ &= \frac{2.739 \text{ in}^2 \times 68.82 \text{ in}^2 \times 6,250,000 \text{ psi}^2}{-8 (30,000,000 \text{ psi})(1.611 \text{ in}^4)(.471 \text{ lb/in.})} \\ &= -6.47 \text{ in.} \end{aligned}$$

9. Height of Neutral Point Above Packer (n):

$$\begin{aligned} &= \frac{A_p((P_i)_{\text{final}} - (P_o)_{\text{final}})}{W_s + W_i - W_o} \\ &= \frac{8.296 \text{ in.} (6,003 \text{ psi} - 3,503 \text{ psi})}{(.542 \text{ lb/in.} + .182 \text{ lb/in.} - .253 \text{ lb/in.})} \\ &= 44,034 \text{ in.} \end{aligned}$$

Since the height of the neutral point above the packer is less than the total length of the tubing string (90,000 in.), no further calculations are necessary. The calculated length change in step 8 is correct.

5

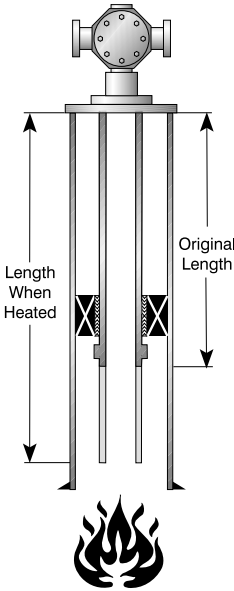

Figure 5.7

**5**

### TEMPERATURE EFFECTS

Force and length changes due to temperature are the only effects which are not caused by pressure changes in the well. Temperature is also the easiest effect to deal with. Simply stated, an object expands when heated and contracts when cooled. Force and length changes are dependent only on the average temperature change in the well and the physical properties of the tubing.

When the average temperature of a well increases (either by injecting hot fluids or by producing hot formation fluid), the tubing will elongate if free to move. If the tubing string is anchored to the packer, the temperature change generates a compressive force on the packer and wellhead. When the average well temperature decreases (by injecting cool fluids), the tubing string will shorten if free to move. If the tubing string is anchored at the packer, decreasing the average well temperature will generate a tensile force on the packer and wellhead.

#### Determining Temperature Effect:

Like the ballooning effect, the temperature effect occurs throughout the entire length of the tubing string. Therefore the *average temperature change* is used to determine the magnitude of the force and length changes. The average temperature of a well is found as follows:

$$T_{avg} = \frac{T_{sur} + BHT}{2} \tag{2-9}$$

where:

$T_{avg}$  = average well temperature (°F)

$T_{sur}$  = surface temperature (°F)

BHT = bottom hole temperature (°F)

#### Example Problem 5-4

What is the average temperature in a well with a surface temperature of 62°F and the temperature at the bottom is 240°F?

# Schlumberger

Solution:

$$T_{avg} = \frac{T_{sur} + BHT}{2}$$

$$T_{avg} = \frac{62^{\circ}\text{F} + 240^{\circ}\text{F}}{2}$$

$$= 151^{\circ}\text{F}$$

Sometimes the surface temperature and bottom hole temperature are not known. In these cases some assumptions must be made to calculate the average temperature. The surface temperature can vary considerably from area to area. The following list is the average temperature 15 to 30 feet below surface (where it remains constant) for several areas. Usually, the surface temperature is available from the company that drilled the well. In the absence of more accurate data, the following values may be used for the surface temperature.

Alberta (North)	= 37 °F
Alberta (South)	= 41 °F
California Coast	= 62 °F
Louisiana (North)	= 67 °F
Louisiana (South)	= 74 °F
Michigan	= 47 °F
Oklahoma	= 62 °F
Rocky Mountain Region	= 50 °F
Texas (East)	= 72 °F
Texas (West)	= 62 °F
Texas (Gulf Coast)	= 74 °F

If the bottom hole temperature is not known, it may be estimated using the geothermal gradient of 1.6 °F per 100 ft of vertical depth from the surface. To find the bottom hole temperature, add 1.6 °F for every 100 ft of depth to the surface temperature. The formula for estimating the bottom hole temperature is:

$$BHT = \frac{T_{sur} + (1.6^{\circ}\text{F} \times h)}{100 \text{ ft}} \quad (5-25)$$

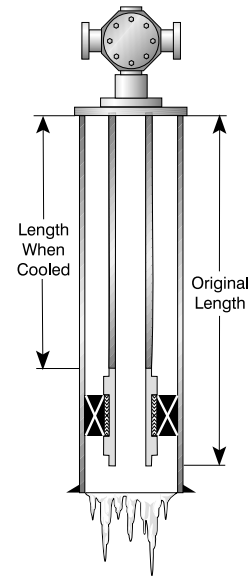

Figure 5.8

5



Where:

BHT = bottom hole temperature (°F)

T<sub>sur</sub> = surface temperature (°F)

h = true vertical depth (ft)

### Example Problem 5-5

Estimate the bottom hole temperature of a 8,600 ft deep well in East Texas.

Solution:

$$\begin{aligned} \text{BHT} &= T_{\text{sur}} + \left( \frac{1.6^\circ \text{F} \times h}{100 \text{ ft}} \right) \\ &= 72^\circ \text{F} + \left( \frac{1.6^\circ \text{F} \times 8,600 \text{ ft}}{100 \text{ ft}} \right) \\ &= 209.6^\circ \text{F} \end{aligned}$$

In the northern U.S., Rocky Mountain regions and Canada, a geothermal gradient of 1.5°F per 100 ft is more accurate. The temperature from the surface to the bottom of the well is assumed to increase uniformly.

When determining temperature effect, there are several important assumptions to make.

1. If the well is producing or fluid is injected into the well, the temperature of the tubing string is assumed to be the same as the fluid inside it. If the well is static, the tubing temperature is assumed to be the same as the surrounding fluid.
2. The temperature of any injected fluid that is not heated is assumed to be at the same temperature as the surrounding air on site.
3. During well servicing (injecting fluids) or production, assume the entire length of the tubing string cools down or heats up to the temperature of the injected or producing fluid. This is not always so, but it is prudent to prepare for the worst possible case.
4. The temperature effect is not immediately felt at the packer. It takes anywhere from several minutes to several hours for the tubing string to heat up or cool down completely. However, it is usually assumed that the temperature effect occurs immediately so that it may be considered at the same time as the other effects.

# Schlumberger

5. The temperature of injected fluids will vary over time. Cold winter nights will decrease the temperature of the tubing string and may cause a packer failure. Always base the average temperature changes on the worst case scenario.

## Temperature Effect Calculations:

Use the following step by step procedure to calculate the force and length changes due to temperature effect:

1. Calculate the initial average tubing temperature  $(T_{avg})_{initial}$ , using equation 2-9.

$$(T_{avg})_{initial} = \frac{(T_{sur})_{initial} + BHT_{initial}}{2}$$

If necessary, estimate the initial surface and bottom hole temperatures as described previously.

2. Calculate the final average tubing temperature  $(T_{avg})_{final}$ , using equation 2-9.

$$(T_{avg})_{final} = \frac{(T_{sur})_{final} + BHT_{final}}{2}$$

3. Calculate the change in average tubing temperature  $(\Delta T)$ , using:

$$\Delta T = (T_{avg})_{final} - (T_{avg})_{initial} \quad (5-26)$$

A negative average temperature change means the tubing string cools down and there will either be a tensile force on the packer or the tubing string will shorten. At this point, the temperature force or length change can be found by using the temperature charts in Appendix E. If using the charts, omit step 4.

4. If the tubing is anchored, calculate the temperature force  $(F_4)$  using:

$$F_4 = 207 A_g \Delta T \quad (5-27)$$

Remember a negative force means a tensile force on the packer. A positive force is compression.

5. If the tubing is free to move, calculate the length change ( $\Delta L_4$ ) due to the temperature effect as follows:

$$\Delta L_4 = L \beta \Delta T \quad (5-28)$$

A negative length change means the tubing shortens. A positive length change means the tubing elongates.

The terms in the preceding formulas are defined as:

$A_s$	= tubing wall cross-sectional area (in <sup>2</sup> )
$BHT_{initial}$	= initial bottom hole temperature (°F)
$BHT_{final}$	= final bottom hole temperature (°F)
$F_4$	= temperature effect force (lbs)
$h$	= true vertical depth (ft)
$L$	= length of tubing string (in.)
$\Delta L_4$	= length change due to temperature effect (in.)
$(T_{avg})_{initial}$	= initial average tubing temperature (°F)
$(T_{avg})_{final}$	= final average tubing temperature (°F)
$(T_{sur})_{initial}$	= initial surface temperature (°F)
$(T_{sur})_{final}$	= final surface temperature (°F)
$\Delta T$	= change in average tubing temperature (°F)
$\beta$	= coefficient of thermal expansion for steel = .0000069 in./in./°F

5

### Example Problem 5-6

For the conditions in example problem 5-1 (shown below), determine:

1. If the seal assembly was a Camco Model 'L' Latch Seal Assembly (tubing not free to move), what would be the temperature effect force?
2. If the seal assembly was a Camco Model 'L' Locator Seal Assembly (tubing free to move up), what would be the length change due to the temperature effect?

Solution:

From the engineering tables:

$$A_s = 1.812 \text{ in}^2$$

# Schlumberger

1. Initial Average Tubing Temperature  $((T_{avg})_{initial})$ :

$$= \frac{(T_{sur})_{initial} + BHT_{initial}}{2}$$

$$= \frac{71^{\circ}\text{F} + 175^{\circ}\text{F}}{2}$$

$$= 123^{\circ}\text{F}$$

2. Final Average Tubing Temperature  $((T_{avg})_{final})$ :

$$= \frac{(T_{sur})_{final} + BHT_{final}}{2}$$

$$= \frac{68^{\circ}\text{F} + 68^{\circ}\text{F}}{2}$$

$$= 68^{\circ}\text{F}$$

3. Change in Average Tubing Temperature  $(\Delta T)$ :

$$= (T_{avg})_{final} - (T_{avg})_{initial}$$

$$= 68^{\circ}\text{F} - 123^{\circ}\text{F}$$

$$= -55^{\circ}\text{F}$$

If the tubing is anchored to the packer (Latch Seal Assembly), the generated force can be found using the "Change in Tubing Force" in Appendix E. From the chart the temperature force is  $-20,500 \text{ lbs } \uparrow$ . Step 4 may be skipped but is shown here for demonstration.

4. Temperature Effect Force  $(F_4)$ :

$$= 207 A_s \Delta T$$

$$= 207 (1.812 \text{ in}^2)(-55^{\circ}\text{F})$$

$$= -20,630 \text{ lbs } \uparrow$$

This is roughly the same answer as the charts give.

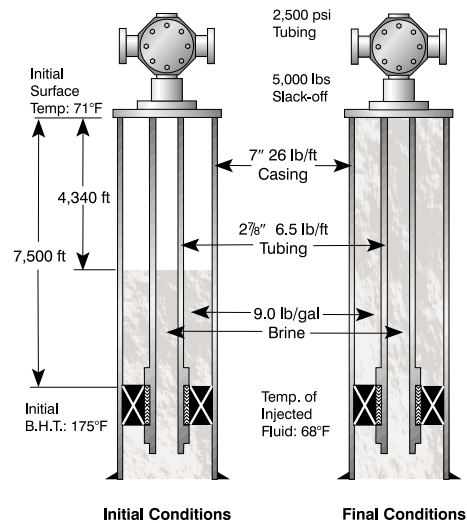

Problem 5-6

5

If the tubing is free to move (Landed Seal Assembly), the temperature effect length change can be found using the “Change in Tubing Length” in Appendix E. From the chart the answer is  $-34''$ . If using the charts, step 5 may be omitted but is shown here for demonstration.

5. Temperature Effect Length Change ( $\Delta L_t$ ):

$$\begin{aligned} &= L \beta \Delta T \\ &= 90,000 \text{ in} \times .0000069 \text{ in./in./}^\circ\text{F} \times (-55^\circ\text{F}) \\ &= -34.2'' \end{aligned}$$

This is roughly the same answer the charts give.

## APPLIED FORCES

As well as the effects of temperature and pressure, any forces applied at the surface must be considered. Tension may be pulled into the tubing string or tubing weight slacked-off onto the packer.

Tubing will stretch according to “Hooke’s Law” if subjected to a tensile force. The tubing stretch charts in Appendix F will give the length and force changes. When under a compressive force, tubing will shorten according to Hooke’s Law and the Buckling Effect. The slack-off charts in Appendix F show the amount the tubing will shorten due to Hooke’s Law and buckling.

### Calculating Applied Force and Length Changes:

Force or length changes from the surface are almost always applied after the tool is set. By carefully monitoring the weight indicator and tubing string, both the force and length changes will be known. However, if one applied effect is known ahead of time, the other is easily found.

If tension is pulled into the packer, and the tension force ( $F_t$ ) is known, the length change ( $L_t$ ) is found using Hooke’s Law:

$$\Delta L_t = \frac{F_t L}{EA_s} \quad (5-29)$$

# Schlumberger

If the length of tubing pulled ( $L_t$ ) is known, the force ( $F_t$ ) due to the tension is found by re-arranging Hooke's Law and solving for the force:

$$F_t = \frac{\Delta L_t EA_s}{L} \quad (5-30)$$

If a known amount of tubing weight ( $F_s$ ) is slacked-off onto the packer, the length change ( $\Delta L_s$ ) is found from:

$$\Delta L_s = \left[ \frac{F_s L}{EA_s} \right] + \left[ \frac{r^2 (F_s)^2}{8EI (W_s + W_i - W_o)} \right] \quad (5-31)$$

The slack-off force ( $F_s$ ) is found by watching the weight indicator.

The terms in the above formulas are defined as:

- $A_s$  = tubing cross-sectional area (in<sup>2</sup>)
- $E$  = modulus of elasticity of steel (30,000,000 psi)
- $F_s$  = slack-off force (lbs)
- $F_t$  = tension force pulled into packer (lbs)
- $I$  = moment of inertia of tubing (in<sup>4</sup>)
- $L$  = length of tubing (in.)
- $\Delta L_s$  = length change due to slack-off (in.)
- $\Delta L_t$  = length change due to tension (in.)
- $r$  = radial clearance between tubing and casing (in.)
- $W_i$  = linear weight of tubing fluid (lbs/in.)

$$= A_i \times \omega_i \times \frac{1 \text{ gal}}{231 \text{ in}^3} \quad (5-18)$$

- $W_o$  = linear weight of annulus fluid (lbs/in.)

$$= A_o \times \omega_o \times \frac{1 \text{ gal}}{231 \text{ in}^3} \quad (5-20)$$

- $W_s$  = linear weight of tubing string (lbs/in.)

$$= \omega (\text{lbs/ft}) \div 12 \text{ in./ft} \quad (5-19)$$

- $\omega$  = linear weight of tubing string (lbs/ft)
- $\omega_i$  = weight of final fluid in tubing (lb/gal)
- $\omega_o$  = weight of final fluid in annulus (lb/gal)

5

The length or force changes due to applied effects are also found using the charts in the engineering tables. The “Stretch Charts” in Appendix F are used to find a force or length change due to tension pulled in the tubing string. The “Slack-Off Charts”, also in Appendix F, can be used to determine the length change from slacking-off weight.

### Set Down and Slack-Off Weights:

When tubing weight is slacked-off, either to set a packer or compensate for pressure effects, the tubing string buckles in the form of a helix. Friction between the tubing and casing supports a significant amount of tubing weight, reducing the weight that reaches the packer. The “Weight on Packer” charts in Appendix F indicate the approximate weight that will reach the packer for a given slack-off force and casing-tubing combination. Charts are supplied for the most common tubing-casing combinations.

The charts were developed from mathematical formulas assuming an average value for the coefficient of friction. Since the friction coefficients are assumed, the charts are not 100% accurate for specific cases and are presented for information only. However, actual field tests in a variety of well fluids indicate the variations are relatively small.

In situations where the tubing weight reaching the packer is insufficient to initiate a pack-off or compensate for pressure effects, it is suggested to apply pressure to the annulus. Pressure in the annulus will tend to straighten the tubing and allow more weight to reach the packer. Annulus pressure will also tend to increase the force on the packing element of a partially actuated set-down type packer.

A final word about slack-off weights. Slack-off weight **is** required to reach the packer to set the packer and to compensate for length and force changes due to the piston effect. Slack-off weight **is not** required to reach the packer to compensate for length and force changes due to temperature or ballooning. These effects occur over the entire length of the tubing string and the set down weight **does not** have to reach the packer.

The following examples demonstrate the use of the equations and the engineering charts.

# Schlumberger

## Example Problem 5-7

A 5 1/2" Camco Model 'SA-3' Retrievable Packer is set at 1,500 ft on 2 7/8" EUE 6.5 lb/ft tubing. The 'SA-3' is a single element, tension set packer that requires a minimum of 10,000 lbs tension to set. How much tubing stretch will it require to set the 'SA-3'?

Solution:

The "Tubing Stretch Chart" for 2 7/8" 6.5 lb/ft tubing is in Appendix F. To find the stretch, locate 1,500 ft on the bottom axis "Depth." Move up the 1,500 ft line until it meets the 10,000 lbs line on "Pull on Tubing." The red line which intersects the point where 1,500 ft and 10,000 lbs meet is the required stretch. The answer is 3".

Using "Hooke's Law", to determine the stretch ( $\Delta L_t$ ):

$$\Delta L_t = \frac{F_t L}{EA_s}$$

$A_s = 1.812 \text{ in}^2$  (tubing cross-sectional area)  
 $E = 30 \times 10^6 \text{ psi}$  (modulus of elasticity for steel)  
 $L = 1,500 \text{ ft} \times 12 \text{ in./ft}$   
 $= 18,000''$  (length of tubing string)  
 $F_t = 10,000 \text{ lbs}$  (tension to set packer)

$$\Delta L_t = \frac{F_t L}{EA_s}$$

$$\Delta L_t = \frac{(10,000 \text{ lbs})(18,000 \text{ in.})}{(30,000,000 \text{ psi})(1.812 \text{ in}^2)}$$

$$= 3.31 \text{ in.} \uparrow$$

## Example Problem 5-8

A 9 5/8" Camco Model 'SR-2' Retrievable Packer, is set at 6,000 ft on 4 1/2" EUE 12.75 lb/ft tubing, inside 9 5/8" 40 lb/ft casing. The 9 5/8" 'SR-2' requires 28,000 lbs compression at the packer to set and has a setting stroke of 24".

1) How much weight must be slacked-off set the 'SR-2'?

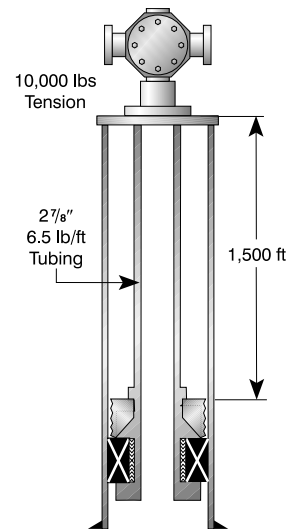

Problem 5-7

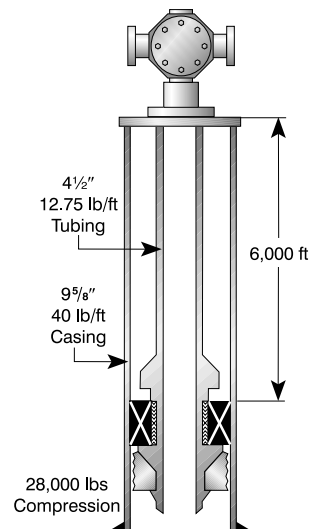

Problem 5-8

5



- 2) How far above the wellhead must the doughnut on the tubing be so that when it lands on the wellhead, the packer is set with the required 28,000 lbs compression?

Solution:

- 1) Use the "Weight on Packer chart for 4 1/2" 12.75 EUE or NU tubing in Appendix F. To get 28,000 lbs compression on the packer, roughly 30,000 lbs of tubing weight must be slacked-off.
- 2) The distance from the wellhead to the doughnut represents the length of tubing slacked-off to set the packer. Using the charts to solve the problem:

Packer Setting Stroke: 24"

To find the length change from slacking-off 30,000 lbs, go to the "Slack-Off Chart" in Appendix F. Go up the 30,000 lbs "Slack-Off Force" line until it meets the 9 5/8" casing line. Move horizontally across and read the "Inches of Compression." To find the buckling component, continue up the 30,000 lbs "Slack-Off Force" line until it meets the 9 5/8" casing line. Move horizontally across and read the "Inches of Buckling."

$$\Delta L_c = 20 \text{ in. (Compression)}$$

$$\Delta L_b = 2 \text{ in. (Buckling)}$$

Total Slack-Off Length ( $\Delta L$ ):

$$\Delta L = \Delta L_c + \Delta L_b + \text{Packer Setting Stroke}$$

$$= 20 \text{ in.} + 2 \text{ in.} + 24 \text{ in.}$$

$$= 46 \text{ in.}$$

Using the slack-off equation to solve the problem:

$$\Delta L_s = \left[ \frac{F_s L}{EA_s} \right] + \left[ \frac{r^2 (F_s)^2}{8EI (W_s + W_i - W_o)} \right]$$

# Schlumberger

$$\begin{aligned}
 A_s &= 3.600 \text{ in}^2 \text{ (tubing cross-sectional area)} \\
 E &= \text{modulus of elasticity for steel (30,000,000 psi)} \\
 F_s &= 30,000 \text{ lbs (slack-off force)} \\
 I &= 8.082 \text{ in}^4 \text{ (moment of inertia of tubing)} \\
 L &= 6,000 \text{ ft} \times 12 \text{ in./ft} \\
 &= 72,000 \text{'' (length of tubing string)} \\
 r &= 2.168 \text{ in. (radial clearance)}
 \end{aligned}$$

$$\begin{aligned}
 W_s &= 12.75 \text{ lb/ft} \times \frac{1 \text{ ft}}{12 \text{ in.}} \\
 &= 1.063 \text{ lb/in. (tubing weight)}
 \end{aligned}$$

Since the packer is balanced when it is set,  $W_i$  and  $W_o$  are the same and their difference will be zero.

$$\begin{aligned}
 \Delta L_s &= \left[ \frac{(30,000 \text{ lbs})(72,000 \text{ in.})}{((30,000,000 \text{ psi})(3.600 \text{ in}^2))} \right] \\
 &+ \left[ \frac{(2.168 \text{ in.})^2 (30,000 \text{ lbs})^2}{8 (30,000,000 \text{ psi})(8.082 \text{ in}^4)(1.063 \text{ lb/in.})} \right] \\
 &= 20 \text{ in.} + 2.05 \text{ in.} \\
 &= 22.05 \text{ in.}
 \end{aligned}$$

Total Slack-Off Length ( $\Delta L$ ):

$$\begin{aligned}
 \Delta L &= \Delta L_s + \text{Packer Setting Stroke} \\
 &= 22.05 \text{ in.} + 24 \text{ in.} \\
 &= 46.05 \text{ in.}
 \end{aligned}$$

Therefore, if the tubing doughnut is placed 46'' above the well-head, the 'SR-2' will be set with the required 28,000 lbs when the doughnut seats in the wellhead.

**5**

## THE TOTAL EFFECT

As mentioned at the beginning of the chapter, the total effect of any pressure and temperature changes after the packer is set is the sum of the individual effects. Like the individual effects, the total effect is either a length change or a force on the packer. If the packer permits movement in the direction of the individual effects, find the sum of the length changes for each individual effect. If the packer does not permit movement in the direction of the individual effects, find the sum of the generated forces.

There will either be a force on the packer or change in the length of the tubing. There cannot be a combination of the two.

### Calculating Total Force ( $F_p$ ):

The total force on the packer is the *vector* sum of the individual forces. Be very careful when dealing with the directions the forces act in. If the tubing is anchored to the packer, the tubing always exerts a compression or tension on the packer. If the tubing is stung through the packer, the tubing can never exert a force on the packer. If the tubing is landed on the packer, there can only be a compression on the packer. Remember a positive or downward force is a compression. If the total force effect is negative, the tubing will shorten because tension cannot be pulled through a landed hook-up. Finally, the force due to buckling is negligible so it is not considered in the total force effect.

The total force on a packer ( $F_p$ ) with tension pulled into the packer is:

$$F_p = F_1 + F_2 + F_4 + F_t \quad (5-32)$$

The total force on a packer ( $F_p$ ) with a slack-off force on the packer is:

$$F_p = F_1 + F_2 + F_4 + F_s \quad (5-33)$$

### Calculating Total Length Change ( $\Delta L_{tot}$ ):

The total length change is the *vector* sum of the length changes due to the individual effects. A positive length change means the tubing elongates and a negative length change means the tubing shortens. If the tubing is anchored to the packer, there cannot be a length change, only a force on the packer. If the tubing is landed on the packer, the tubing can only shorten (negative length change)

# Schlumberger

because the packer will not allow the tubing to move down. If the tubing is stung through the packer, a positive length change indicates the tubing elongates and a negative total length change means the tubing shortens.

The total length change ( $\Delta L_{tot}$ ) with tension is:

$$\Delta L_{tot} = \Delta L_1 + \Delta L_2 + \Delta L_3 + \Delta L_4 + \Delta L_t \quad (5-34)$$

The total length change ( $\Delta L_{tot}$ ) with a slack-off is:

$$\Delta L_{tot} = \Delta L_1 + \Delta L_2 + \Delta L_3 + \Delta L_4 + \Delta L_s \quad (5-35)$$

The above terms are defined as:

- $F_s$  = slack-off force (lbs)
- $F_t$  = tension pulled into packer(lbs)
- $F_p$  = total force on packer (lbs)
- $F_1$  = force on packer due to the piston effect (lbs)
- $F_2$  = force on packer due to ballooning (lbs)
- $F_4$  = force on packer due to temperature effects (lbs)
- $\Delta L_s$  = length change due to slack-off force (in.)
- $\Delta L_t$  = length change due to tension pulled into packer (in.)
- $\Delta L_{tot}$  = total length change of tubing string (in.)
- $\Delta L_1$  = length change due to the piston effect (in.)
- $\Delta L_2$  = length change due to ballooning (in.)
- $\Delta L_3$  = length change due to buckling (in.)
- $\Delta L_4$  = length change due to temperature effects (in.)

The individual effects may act in different directions. For instance, many applied forces are to counter the effects of temperature and pressure. Subtract effects that act in opposite directions and add ones that act in the same direction. If the equations are used to determine the effects, the signs will indicate which direction the force or length change is in. It is always a good idea to write an arrow beside the force to indicate its direction, especially when using the charts. Finally, use the method which is most comfortable; either the charts or the equations. If there is any uncertainty, one method can be used to check the other.

## Example Problem 5-9

For the conditions in Example Problem 5-1, determine the total effect of all the pressure and temperature changes and the applied forces:

1) if the seal assembly is a Model 'L' Latch Seal Assembly (tubing not free to move).

2) if the seal assembly is a Model 'L' Locator Seal Assembly (tubing free to move up).

Solution:

1) Tubing not free to move:

Piston Force: (from Example Problem 5-1)

$$F_1 = -12,713 \text{ lbs } \uparrow$$

Ballooning Force: (from Example Problem 5-2)

$$F_2 = -5,927 \text{ lbs } \uparrow$$

Buckling Force is negligible.

Temperature Force: (from Example Problem 5-6)

$$F_4 = -20,630 \text{ lbs } \uparrow$$

Slack-Off Force: (given in problem statement)

$$F_s = 5,000 \text{ lbs } \downarrow$$

Total Force on Packer:

$$\begin{aligned} F_p &= F_1 + F_2 + F_4 + F_s \\ &= (-12,713 \text{ lbs } \uparrow) + (-5,927 \text{ lbs } \uparrow) + (-20,630 \text{ lbs } \uparrow) \\ &\quad + 5,000 \text{ lbs } \downarrow \\ &= -34,270 \text{ lbs } \uparrow \end{aligned}$$

2) Tubing Free to Move Up.

Piston Effect: (from Example Problem 5-1)

$$\Delta L_1 = -21.05 \text{ in. } \uparrow$$

# Schlumberger

Ballooning Effect: (from Example Problem 5-2)

$$\Delta L_2 = -9.80 \text{ in. } \uparrow$$

Buckling Effect: (from Example Problem 5-3)

$$\Delta L_3 = -6.47 \text{ in. } \uparrow$$

Temperature Effect: (from Example Problem 5-6)

$$\Delta L_4 = -34.2 \text{ in. } \uparrow$$

Slack-Off Effect:

$$\begin{aligned}\Delta L_s &= \left[ \frac{F_s L}{EA_s} \right] + \left[ \frac{r^2 (F_s)^2}{8EI (W_s + W_1 - W_0)} \right] \\ &= \left[ \frac{(5,000 \text{ lbs})(90,000 \text{ in})}{(30 \times 10^6 \text{ psi})(1.812 \text{ in}^2)} \right] + \left[ \frac{(1.701 \text{ in})^2 (5,000 \text{ lb})^2}{8 (30 \times 10^6 \text{ psi})(1.611 \text{ in}^4)(.542 + .182 - .253)} \right] \\ &= 8.28 \text{ in. } + .40 \text{ in.} \\ &= 8.68 \text{ in. } \downarrow\end{aligned}$$

(Or get from "Slack-Off Chart" in Appendix F.)

Total Length Change:

$$\begin{aligned}\Delta L_{\text{tot}} &= \Delta L_1 + \Delta L_2 + \Delta L_3 + \Delta L_4 + \Delta L_s \\ &= (-21.05 \text{ in. } \uparrow) + (-9.80 \text{ in. } \uparrow) + (-6.47 \text{ in. } \uparrow) \\ &\quad + (-34.20 \text{ in. } \uparrow) + 8.68 \text{ in. } \downarrow \\ &= -62.86 \text{ in. } \uparrow\end{aligned}$$

5

## 5

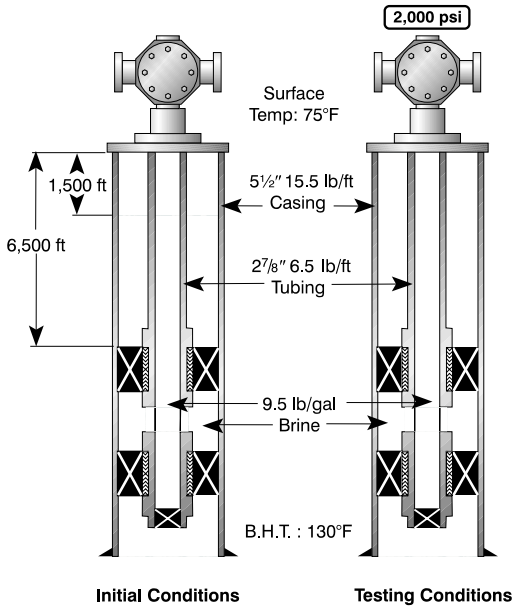

Problem 5-10

### Example Problem 5-10:

An oil company wishes to use an 'Omegamatic' retrievable packer in conjunction with a retrievable bridge plug to locate a leak in the well casing. The casing is 5 1/2" 15.5 lb/ft and the packer is run on 2 7/8" 6.5 lb/ft tubing. The first test depth is 6,500 ft and the test program calls for 2,000 psi applied tubing pressure. The well fluid is 9.5 lb/gal brine and is encountered at 1,500 ft. How much tubing weight is required if the 'Omegamatic' needs 20,000 lbs compression to set? If the tubing pressure is bled off after the test, what is the hook load to release the 'Omegamatic' packer?

#### Well Data:

- Packer Depth: 6,500 ft
- Casing: 5 1/2" 15.5 lb/ft
- Tubing: 2 7/8" EUE 6.5 lb/ft
- Initial Well Fluid: 9.5 lb/gal brine @ 1,500 ft
- Final Annulus Fluid: 9.5 lb/gal brine
- Final Tubing Fluid: 9.5 lb/gal brine @ 75° F

# Schlumberger

Surface Temp.: 75° F  
B.H.T.: 130° F

Solution:

From the engineering tables:

Casing ID area ( $A_{\text{csg}}$ ): 19.244 in<sup>2</sup>  
Tubing ID area ( $A_i$ ): 4.680 in<sup>2</sup>  
Tubing OD area ( $A_o$ ): 6.492 in<sup>2</sup>  
Tubing Wall Area ( $A_s$ ): 1.812 in<sup>2</sup>  
Annulus fluid gradient ( $fg_o$ ): .494 psi/ft  
Tubing fluid gradient ( $fg_i$ ): .494 psi/ft  
Packer Valve Area ( $A_p$ ): 6.582 in<sup>2</sup>  
(Camco technical manual)  
Unloader Piston Area ( $A_u$ ): 4.896 in<sup>2</sup>  
(Camco technical manual)  
Button Seal Area ( $A_b$ ): 3.142 in<sup>2</sup>  
(Camco technical manual)

2,000 psi applied to tubing.

5

## Tubing Calculations:

Initial Tubing Pressure ( $(P_i)_{\text{initial}}$ ):

$$\begin{aligned}(P_i)_{\text{initial}} &= fg_i \times h \\ &= .494 \text{ psi/ft} \times 5,000 \text{ ft} \\ &= 2,470 \text{ psi}\end{aligned}$$

Final Tubing Pressure ( $(P_i)_{\text{final}}$ ):

$$\begin{aligned}(P_i)_{\text{final}} &= fg_i \times h + (P_{\text{iapp}})_{\text{final}} \\ &= .494 \text{ psi/ft} \times 6,500 \text{ ft} + 2,000 \text{ psi} \\ &= 5,211 \text{ psi}\end{aligned}$$



Change in Tubing Pressure ( $\Delta P_i$ ):

$$\begin{aligned}\Delta P_i &= (P_i)_{\text{final}} - (P_i)_{\text{initial}} \\ &= 5,211 \text{ psi} - 2,470 \text{ psi} \\ &= 2,741 \text{ psi}\end{aligned}$$

Initial Average Tubing Pressure ( $(P_{ia})_{\text{initial}}$ ):

$$\begin{aligned}(P_{ia})_{\text{initial}} &= \frac{(P_i)_{\text{app}} + (P_i)_{\text{initial}}}{2} \\ &= \frac{0 + 2,470 \text{ psi}}{2} \\ &= 1,235 \text{ psi}\end{aligned}$$

Final Average Tubing Pressure ( $(P_{ia})_{\text{final}}$ ):

$$\begin{aligned}(P_{ia})_{\text{final}} &= \frac{(P_i)_{\text{app}} + (P_i)_{\text{final}}}{2} \\ &= \frac{2,000 + 5,211 \text{ psi}}{2} \\ &= 3,606 \text{ psi}\end{aligned}$$

Change in Average Tubing Pressure ( $\Delta P_{ia}$ ):

$$\begin{aligned}\Delta P_{ia} &= (P_{ia})_{\text{final}} - (P_{ia})_{\text{initial}} \\ &= 3,606 \text{ psi} - 1,235 \text{ psi} \\ &= 2,371 \text{ psi}\end{aligned}$$

5

# Schlumberger

Annulus Calculations:

$$\text{Initial Annulus Pressure } ((P_o)_{\text{initial}}) = (P_i)_{\text{initial}} = 2,470 \text{ psi}$$

Final Annulus Pressure  $((P_o)_{\text{final}})$ :

$$\begin{aligned}(P_o)_{\text{final}} &= f_{g_o} \times h + (P_{oapp})_{\text{final}} \\ &= .494 \text{ psi /ft} \times 6,500 \text{ ft} + 0 \text{ psi} \\ &= 3,211 \text{ psi}\end{aligned}$$

Change in Annulus Pressure  $(\Delta P_o)$ :

$$\begin{aligned}\Delta P_o &= (P_o)_{\text{final}} - (P_o)_{\text{initial}} \\ &= 3,211 \text{ psi} - 2,470 \text{ psi} \\ &= 741 \text{ psi}\end{aligned}$$

Initial Average Annulus Pressure  $(P_{oa})_{\text{initial}} = (P_{ia})_{\text{initial}} = 1,235 \text{ psi}$

Final Average Annulus Pressure  $((P_{oa})_{\text{final}})$ :

$$\begin{aligned}(P_{oa})_{\text{final}} &= \frac{(P_o)_{\text{final}} + (P_{oapp})_{\text{final}}}{2} \\ &= \frac{3,211 \text{ psi} + 0 \text{ psi}}{2} \\ &= 1,606 \text{ psi}\end{aligned}$$

Change in Average Annulus Pressure  $(\Delta P_{oa})$ :

$$\begin{aligned}\Delta P_{oa} &= (P_{oa})_{\text{final}} - (P_{oa})_{\text{initial}} \\ &= 1,606 \text{ psi} - 1,235 \text{ psi} \\ &= 371 \text{ psi}\end{aligned}$$

5

## Piston Force:

$$\begin{aligned} F_1 &= \Delta P_o (A_p - A_o) - \Delta P_i (A_p - A_i) \\ &= 741 \text{ psi } (6.582 \text{ in}^2 - 6.492 \text{ in}^2) \\ &\quad - 2,741 \text{ psi } (6.582 \text{ in}^2 - 4.680 \text{ in}^2) \\ &= -5,147 \text{ lbs}\uparrow \end{aligned}$$

An 'Omegamatic' retrievable packer has a hydraulic unloader piston that creates a downward force on the packer mandrel (and tubing string) if the tubing pressure exceeds the annulus pressure. The downward force is equal to the effective unloader piston area times the change in differential pressure:

$$\begin{aligned} F_u &= A_u (\Delta P_i - \Delta P_o) \\ &= 4.896 \text{ in}^2 (2,741 \text{ psi} - 741 \text{ psi}) \\ &= 9,792 \text{ lbs}\downarrow \end{aligned}$$

So the total piston force on the packer is:

$$\begin{aligned} F_1 &= -5,147 \text{ lbs}\uparrow + 9,792 \text{ lbs}\downarrow \\ &= 4,645 \text{ lbs}\downarrow \end{aligned}$$

## Ballooning Force:

Get the "Ballooning Force" from the Ballooning charts in Appendix E, or do the calculation shown below.

$$\begin{aligned} F_2 &= .6 [\Delta P_{oa} A_o - \Delta P_{ia} A_i] \\ &= .6 [371 \text{ psi} \times 6.492 \text{ in}^2 - 2,371 \text{ psi} \times 4.680 \text{ in}^2] \\ &= -5,213 \text{ lbs}\uparrow \end{aligned}$$

# Schlumberger

## Temperature Force:

Initial Average Tubing Temperature  $(T_{avg})_{initial}$ :

$$\begin{aligned}(T_{avg})_{initial} &= \frac{T_{sur} + BHT}{2} \\ &= \frac{75^{\circ}\text{F} + 130^{\circ}\text{F}}{2} \\ &= 103^{\circ}\text{F}\end{aligned}$$

Final Average Tubing Temperature  $(T_{avg})_{final}$ :  $75^{\circ}\text{F}$

Change in Average Tubing Temperature  $(\Delta T)$ :

$$\begin{aligned}\Delta T &= (T_{avg})_{final} - (T_{avg})_{initial} \\ &= 75^{\circ}\text{F} - 103^{\circ}\text{F} \\ &= -28^{\circ}\text{F}\end{aligned}$$

Temperature Force  $(F_4)$ :

$$\begin{aligned}F_4 &= E A_s \beta \Delta T \\ &= 30,000,000 \text{ psi} \times 1.812 \text{ in}^2 \\ &\quad \times .0000069 \text{ in./in.}^{\circ}\text{F} \times -28^{\circ}\text{F} \\ &= -10,502 \text{ lbs}\uparrow\end{aligned}$$

**Tubing to Packer Force  $(F_p)$ :**

$$\begin{aligned}F_p &= F_1 + F_2 + F_4 + F_s \\ &= 4,645 \text{ lbs}\downarrow + -5,213 \text{ lbs}\uparrow + -10,502 \text{ lbs}\uparrow + F_s\downarrow \\ &= -11,070 \text{ lbs}\uparrow + F_s\end{aligned}$$

5

An ‘Omegamatic’ needs a net compressive force to hold the valve closed. We need to set the packer with 20,000 lbs and compensate for the pressure and temperature effects. To compensate for the ballooning and temperature effects, the slack off weight is not required to reach the packer. So only 20,000 lbs must reach the packer. Using the “Weight on Packer” chart in Appendix F, for 27/8” tubing in 5 1/2” casing, roughly 24,000 lbs must be slacked off to set the packer. To compensate for the temperature and ballooning effect, 15,715 lbs of tubing weight must be slacked off. A total of 39,715 lbs of tubing weight needs to be slacked off. Using the “Weight on Packer” chart once again, of the total slack off force of 39,715 lbs, roughly 25,500 lbs will reach the packer.

The tubing to packer force is:

$$\begin{aligned} F_p &= -11,070 \text{ lbs}\uparrow + 25,500 \text{ lbs}\downarrow \\ &= 14,430 \text{ lbs}\downarrow \end{aligned}$$

### Net Force Across Packer ( $F_p$ ):

To calculate the net force across the packer, consider all the forces acting on the tool at the particular time in question. There is a downward force equal to the annulus pressure times the annular area above the packer, an upward force equal to the tubing pressure times the area below the packer, and there is the tubing to packer force ( $F_p$ ) which may act either up or down. In the case of the ‘Omegamatic’ packer, if the tubing pressure is higher than the annulus pressure, there will also be a downward force due to the unloader piston equal to the differential pressure times the unloader piston area. The following equation gives the net force on an ‘Omegamatic’ packer.

$$\begin{aligned} F_n &= (P_o)_{\text{release}} (A_o - A_p) - (P_i)_{\text{release}} (A_p - A_i) \\ &\quad + A_u [(P_i)_{\text{release}} - (P_o)_{\text{release}}] + F_p \end{aligned}$$

The term dealing with the unloader piston may be dropped if a packer without a hydraulic hold down system is used, or if, in the case of a packer with an unloader piston, the annulus pressure is higher than the tubing pressure. In this example, the net force on the ‘Omegamatic’ packer during testing is:

# Schlumberger

$$\begin{aligned}F_n &= (P_o)_{final}(A_{csg} - A_p) - (P_i)_{final}(A_{csg} - A_i) \\ &\quad + A_u[(P_i)_{final} - (P_o)_{final}] + F_p \\ &= 3,211 \text{ psi } (19.244 \text{ in}^2 - 6.492 \text{ in}^2) \\ &\quad - 5,211 \text{ psi } (19.244 \text{ in}^2 - 4.680 \text{ in}^2) \\ &\quad + 4.896 \text{ in}^2 [5,211 \text{ psi} - 3,211 \text{ psi}] + 14,430 \text{ lbs}\downarrow \\ &= 40,947 \text{ lbs}\downarrow - 75,893 \text{ lbs}\uparrow + 9,792 \text{ lbs}\downarrow \\ &\quad + 14,430 \text{ lbs}\downarrow \\ &= -10,724 \text{ lbs}\uparrow\end{aligned}$$

There is a net upward force of 10,724 lbs. An ‘Omegamatic’ packer has a set of hydraulically activated hold downs which keep the packer from moving up the well bore if the tubing pressure is greater than the annulus pressure. A conservative approximation of the hold down force is given by:

$$F_b = n [(P_i)_{final} - (P_o)_{final}] A_b$$

Where:

$$\begin{aligned}n &= \text{total number of buttons} \\ A_b &= \text{area of individual buttons (from technical manual)}\end{aligned}$$

The approximate hold down force during testing is:

$$\begin{aligned}F_b &= n [(P_i)_{final} - (P_o)_{final}] A_b \\ &= 6 [5,211 \text{ psi} - 3,211 \text{ psi}] 3.142 \text{ in}^2 \\ &= 37,704 \text{ lbs}\downarrow\end{aligned}$$

The available hold down force is much greater than the net upward force on the packer, so, the packer will hold.

## Hook Load to Release Packer:

When determining the releasing hook load for a retrievable packer, consider all forces on the tubing string at the time of release. There is a downward force equal to the annulus pressure times the difference between the packer valve area and the tubing

5

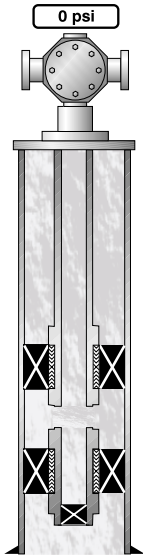

Releasing

**Problem 5-11**

**5**

O.D. and an upward force equal to the tubing pressure times the difference between the packer valve area and the tubing I.D. The following equation will give the releasing hook load for a retrievable packer:

$$(W_{hl})_{\text{release}} = W_{\text{air}} - [(P_o)_{\text{release}} (A_o - A_p) + (P_i)_{\text{release}} (A_p - A_i)]$$

In the case of the 'Omegamatic' packer, if the tubing pressure is higher than the annulus pressure, the unloader piston also produces a downward force on the mandrel equal to the unloader piston area times the differential pressure. If there is no pressure differential at the time of release or the annulus pressure is higher than the tubing pressure, the above equation will give the releasing hook load.

$$\begin{aligned} (W_{hl})_{\text{release}} &= W_{\text{air}} - [(P_o)_{\text{release}} (A_o - A_p) + (P_i)_{\text{release}} (A_p - A_i)] \\ &= 6.5 \text{ lb/ft} \times 6,500 \text{ ft} \\ &\quad - [3,211 \text{ psi} (6.492 \text{ in}^2 - 6.582 \text{ in}^2) \\ &\quad + 3,211 \text{ psi} (6.582 \text{ in}^2 - 4.680 \text{ in}^2)] \\ &= 42,250 \text{ lbs}\downarrow + 289 \text{ lbs}\downarrow - 6,107 \text{ lbs}\uparrow \\ &= 36,432 \text{ lbs}\downarrow \end{aligned}$$

When evaluating any tool installation, always check the effects of changing well conditions on the tubing string. Tubing has definite strength capabilities which must never be exceeded. The tubing strength is limited by the amount of stress it can withstand before undergoing permanent deformation. This chapter addresses several concerns about tubing strength:

- Is the tubing strong enough to withstand the forces due to changing well conditions?
- Is the tubing yield strength high enough to set and release the tool under nominal and emergency conditions?
- Will compressive stresses permanently damage the tubing string?
- Can the tubing withstand the burst and collapse stresses of the expected pressure differentials?

### Tubing Classification

Tubing is available in a wide variety of sizes, materials and strengths. Oilfield tubulars are specified by outside diameter, weight per foot, connection and material grade. Oilfield tubular specifications generally conform to standards issued by the American Petroleum Institute (API). Below is a common API tubing specification and the definitions of each term.

$\underbrace{2\frac{7}{8}''}_{1}$   $\underbrace{\text{EUE}}_{2}$   $\underbrace{6.5 \text{ lb/ft}}_{3}$   $\underbrace{\text{J-55}}_{4 \ 5}$

1. Nominal outside diameter of the tubing body.
2. Type of connection. In this case an **External Upset End (EUE)**. The pin end of an EUE connection is larger than the tubing body.
3. Weight in lbs-per-foot of tubing length. For a given nominal outside diameter, there are usually several different weights available.
4. The letter is the API material designation. It represents the material composition and state.
5. The number represents the tubing yield strength in thousands of pounds per square inch (psi). In this case the tubing yield strength is 55,000 psi.





The tubing yield strength is the maximum stress which the tubing can withstand before undergoing permanent deformation. Stress is the amount of force per unit area within a solid material. Although stress and pressure have the same units, they are *not* the same. Stress is the result of a force acting on a solid material. So long as the created stress is less than the tubing yield strength, the tubing will return to its original shape once the stress creating force is removed. If the tubing yield strength is surpassed, it will not return to its original shape and is permanently damaged. The tubing yield strength depends on the type of steel and the manufacturing process. The generated stress depends on the tubing size, shape and the type and size of applied force.

Different types of loading conditions have different effects on the tubing string. For instance, cyclical loading to high stress values (even though less than the yield strength) will considerably weaken the tubing string. Old or corroded tubing may have substantially weaker yield points. If the maximum tension the tubing may be subjected to is not specified, the following guidelines are recommended:

- 1) Do not exceed 80% of the tubing yield strength.
- 2) For continuous loads, never exceed 75% of the tubing yield strength.
- 3) For continually fluctuating or cyclical loads (discussed later in more detail), do not exceed 50% of the tubing yield strength.

## 6

The “Tubing Performance Properties” tables in Appendix A, lists the mechanical properties of different types and sizes of tubing. The “Collapse Resistance” is the differential pressure from outside to inside which the tubing can withstand before collapsing. The “Internal Joint (Burst) Pressure” is the maximum pressure differential from inside to outside, the tubing can withstand before rupturing. The “Joint Yield Strength” is the tension in pounds that the tubing connection can withstand before yielding. The connection strength is usually less than the tubing body strength. Premium and EUE connections are usually as strong or stronger than the tubing body.

### Top Joint Tension

The top joint of the tubing string is under the most stress since it must carry the weight of all tubing joints below it in addition to

# Schlumberger

any tension pulled into the tubing string. If the force on the top joint exceeds the joint yield strength, the tubing size or the planned packer installation needs to be changed.

To determine the top joint tension, consider all forces acting on the tubing string. There are three forces acting on the tubing string:

- The weight of the tubing string in air (chapter three).
- The packer to tubing force (chapter five).
- The force due to pressure acting on the end area of the tubing.

From chapter three, the formula for the weight of the tubing string in air ( $W_{\text{air}}$ ) is:

$$W_{\text{air}} = \omega \times L \quad (3-2)$$

where:

- $L$  = total length of the tubing string (ft)
- $W_{\text{air}}$  = weight of the tubing string in air (lbs)
- $\omega$  = linear weight per foot of tubing string (lb/ft)

The packer to tubing force ( $F_p$ ) was given in chapter five as:

$$F_p = F_1 + F_2 + F_4 + F_t \quad (5-32)$$

with tension pulled into the packer and:

$$F_p = F_1 + F_2 + F_4 + F_s \quad (5-33)$$

with weight slacked off onto the packer.

Where:

- $F_1$  = piston effect force (lbs)
- $F_2$  = ballooning effect force (lbs)
- $F_4$  = temperature effect force (lbs)
- $F_p$  = packer to tubing force (lbs)
- $F_s$  = slack-off force (lbs)
- $F_t$  = tension pulled into packer (lbs)

# 6

When determining the packer to tubing force, pay careful attention to the type of tubing to packer hook-up. If the tubing is free to move, the piston force will affect the top joint tension. If the tubing is not free to move, the piston force is absorbed by the packer and does not affect the top joint tension.

The end area force ( $F_a$ ) on the tubing string is found using:

$$F_a = [(A_p - A_o) (P_o)_{final}] - [(A_p - A_i)(P_i)_{final}] \quad (6-1)$$

Where:

- $A_i$  = tubing inside area (in<sup>2</sup>)
- $A_p$  = packer seal bore or valve area (in<sup>2</sup>)
- $A_o$  = tubing outside area (in<sup>2</sup>)
- $F_a$  = end area force (lbs)
- $(P_o)_{final}$  = final total annulus pressure @ packer (psi)
- $(P_i)_{final}$  = final total tubing pressure @ packer (psi)

Equation 6-1 is very similar to that used to calculate the piston effect force (equation 5-7). To determine the piston force, the *change* in the tubing and annulus pressure are used. When calculating the end area force on the tubing, the *final* pressure for the condition being analyzed is used. Be careful not to get the two forces confused. The end area force is the same as the hydraulic force for hook-loads in chapter four. As in previous cases, the sign indicates the direction the forces act.

As always, the tubing to packer hook-up is important. If the tubing is stung through the packer, there can be no packer to tubing force. If the tubing is latched, there will always be a tubing to packer force, either tension or compression. Landed tubing will only exert a compressive packer to tubing force, since tension can not be pulled into a landed or located seal assembly.

### Calculating Top Joint Tension ( $F_{ij}$ )

Use the following step by step procedure to determine the top joint tension ( $F_{ij}$ ):

1. Determine the packer to tubing force ( $F_p$ ) using equation (5-32) or (5-33).
2. Find the end area force ( $F_a$ ) using formula (6-1).

# Schlumberger

3. Determine the weight of the tubing string in air ( $W_{air}$ ).
4. The top joint tension ( $F_{ij}$ ) is found using the following formula:

$$F_{ij} = W_{air} + F_a - F_p \quad (6-2)$$

Example problem 6-1 illustrates the above principles.

### Example Problems 6-1:

A 7" Camco Model 'SOT-1' (3.192" packer valve diameter) is set on wireline at 8,200 feet in 7" 32 lb/ft casing. After latching 2 7/8" 6.5 lb/ft EUE J-55 tubing, 15,000 lbs is slacked-off onto the packer. The well fluid is 9.6 lb/gal brine and is initially encountered at 2,000 feet. The annulus is then filled with 9.6 lb/gal brine. The well is a water injection well. Fresh water (8.34 lb/gal) at 70°F is injected at 1,200 psi. The initial surface temperature is 65°F and the bottom hole temperature is 160°F. Using the methods of chapter five, the individual effects for these conditions are:

$$\begin{aligned} \text{Piston Force } (F_1) &= -4,024 \text{ lbs } \uparrow \\ \text{Ballooning Force } (F_2) &= -2,079 \text{ lbs } \uparrow \\ \text{Temperature Force } (F_4) &= -15,941 \text{ lbs } \uparrow \end{aligned}$$

Is the tubing yield strength exceeded under these conditions?

Solution:

1. Packer to Tubing Force ( $F_p$ ):  
Since the tubing is latched to the packer and cannot move, ignore the piston force ( $F_1$ )

$$\begin{aligned} F_p &= F_2 + F_4 + F_s \\ &= (-2,079 \text{ lbs } \uparrow) + (-15,941 \text{ lbs } \uparrow) \\ &\quad + 15,000 \text{ lbs } \downarrow \\ &= -3,020 \text{ lbs } \uparrow \end{aligned}$$

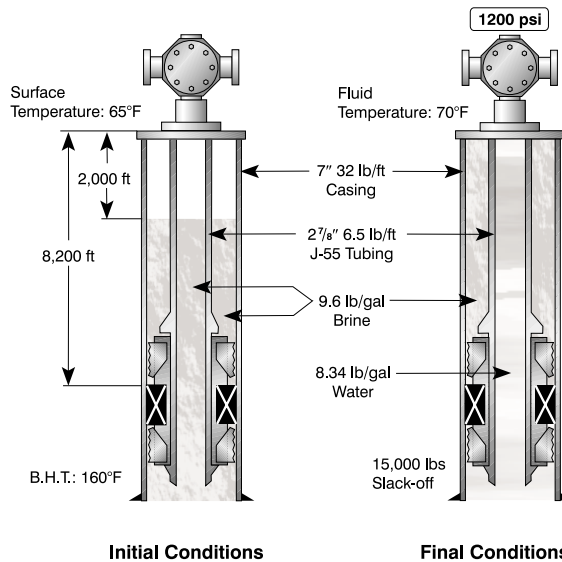

Problem 6-1

2. End Area Force ( $F_a$ ):

$$F_a = [(A_p - A_o) (P_o)_{\text{final}}] - [(A_p - A_i) (P_i)_{\text{final}}]$$

$$A_i = 4.680 \text{ in}^2$$

$$A_p = 8.002 \text{ in}^2$$

$$A_o = 6.492 \text{ in}^2$$

$$\begin{aligned} (P_i)_{\text{final}} &= fg \times h + (P_{i\text{app}})_{\text{final}} \\ &= .434 \text{ psi/ft} \times 8,200 \text{ ft} + 1,200 \text{ psi} \\ &= 4,759 \text{ psi} \end{aligned}$$

$$\begin{aligned} (P_o)_{\text{final}} &= fg \times h \\ &= .499 \text{ psi/ft} \times 8,200 \text{ ft} \\ &= 4,092 \text{ psi} \end{aligned}$$

$$\begin{aligned} F_a &= [(8.002 \text{ in}^2 - 6.492 \text{ in}^2) 4,092 \text{ psi}] \\ &\quad - [(8.002 \text{ in}^2 - 4.680 \text{ in}^2) 4,759 \text{ psi}] \\ &= -9,630 \text{ lbs } \uparrow \end{aligned}$$

3. Tubing Weight in Air ( $W_{\text{air}}$ ):

$$\begin{aligned} W_{\text{air}} &= w \times L \\ &= 6.5 \text{ lb/ft} \times 8,200 \text{ ft} \\ &= 53,300 \text{ lbs } \downarrow \end{aligned}$$

4. Top Joint Tension ( $F_{\text{tj}}$ ):

$$\begin{aligned} F_{\text{tj}} &= W_{\text{air}} + F_a - F_p \\ &= 53,300 + (-9,630 \text{ lbs } \uparrow) - (-3,020 \text{ lbs } \uparrow) \\ &= 53,300 \text{ lbs} - 9,630 \text{ lbs} + 3,020 \text{ lbs} \\ &= 46,690 \text{ lbs } \downarrow \end{aligned}$$

6

# Schlumberger

Note the change in direction of the tubing to packer force ( $F_p$ ). A negative tubing to packer force is tension on the packer. Tension on the packer is also tension on the top joint and will increase the hook-load. However, the force on the top joint is opposite that on the packer, hence the sign change. Subtracting the negative tubing to packer force in step four is the same as adding it.

From the “Tubing Performance Properties” table in Appendix A, the joint yield strength for 27/8” 6.5 lb/ft EUE J-55 tubing is 99,600 lbs. To determine if the joint yield strength has been exceeded, the safety factor must be applied. For continuous loads, the maximum recommended tension the tubing can withstand is 75% of the joint yield strength. Therefore:

$$\begin{aligned} F_{\max} &= .75 \times 99,600 \text{ lbs} \\ &= 74,700 \text{ lbs} \end{aligned}$$

Under these conditions, the top joint tension is less than 75% of the tubing yield strength and is a safe value. Finally, the highest pressures expected during the installation or well servicing should be checked against the burst and collapse pressure ratings in the “Tubing Performance Properties” table. If the expected pressures are higher than the ratings, the installation should be redesigned. The maximum expected *differential pressure* is what must be checked. From the “Tubing Performance Properties” table in Appendix A, for 27/8” 6.5 lb/ft J-55 tubing:

$$\begin{aligned} \text{Burst Pressure} &= 7,260 \text{ psi} \\ \text{Collapse Pressure} &= 7,680 \text{ psi} \end{aligned}$$

The maximum pressure differential encountered is:

$$\begin{aligned} P_{\text{diff}} &= (P_i)_{\text{final}} - (P_o)_{\text{final}} \\ &= 4,759 \text{ psi} - 4,092 \text{ psi} \\ &= 667 \text{ psi} - \text{tubing} \end{aligned}$$

This is a differential pressure in favor of the tubing, so the burst pressure is important. In this case the differential pressure is much less than the burst pressure rating, and is not a concern. Remem-

6

ber to always use the worst case when calculating any pressure differentials or loads on the tubing. This way you can be sure the proposed installation will proceed as planned.

The tubing string will elongate from its own weight while running it in to a well. It is sometimes necessary to find the true length of the tubing. For instance, setting a packer between two sets of perforations that are close together requires knowing the true string length.

The tension on the tubing (caused by its own weight) varies from the top of the string which is subject to the entire string weight to the bottom which supports no weight. The average value of the tubing string weight in fluid which is half of the total string weight, is used to calculate the stretch. The tubing weight in fluid is given by formula (3.5). Hooke's Law is used to determine the tubing stretch or it may be read from the "Tubing Stretch" charts.

**Example Problem 6-2:**

A 5 1/2" Camco 'Omegamatic' Retrievable Packer is to be set at 8,400 ft on 2 3/8" 4.7 lb/ft tubing. The well is full of 9.2 lb/gal brine. What is the elongation of the tubing string due to its own weight?

Solution:

- 1. Well Pressure at 8,400 ft (P):

$$\begin{aligned}
 P &= fg \times h \\
 &= .478 \text{ psi/ft} \times 8,400 \text{ ft} \\
 &= 4,015 \text{ psi}
 \end{aligned}$$

- 2. Weight of tubing in fluid ( $W_{\text{fluid}}$ ):

$$\begin{aligned}
 W_{\text{fluid}} &= \omega \times L - \Sigma F_b && (6-3) \\
 &= \omega \times L - PA_s \\
 &= (4.7 \text{ lb/ft} \times 8,400 \text{ ft}) - (4,015 \text{ psi} \times 1.304 \text{ in}^2) \\
 &= 39,480 \text{ lbs} - 5,236 \text{ lbs} \\
 &= 34,244 \text{ lbs} \downarrow
 \end{aligned}$$

**6**

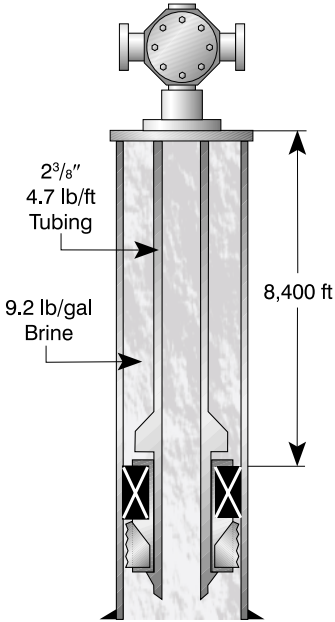

**Problem 6-2**

# Schlumberger

3. Average Tubing Weight in Fluid ( $W_{ave}$ ):

$$\begin{aligned} &= \frac{1}{2} \times 34,244 \text{ lbs} \\ &= 17,122 \text{ lbs} \end{aligned}$$

4. Tubing Stretch ( $\Delta L$ ):

The tubing stretch may be read from the “Tubing Stretch” chart in Appendix F, using 17,122 lbs as the pull on the tubing. The Hooke’s Law calculation is shown below.

$$\begin{aligned} \Delta L &= \frac{FL}{EA_s} \\ &= \frac{(17,122 \text{ lbs})(100,800 \text{ in.})}{(30 \times 10^6 \text{ psi})(1.304 \text{ in}^2)} \\ &= 44.1 \text{ in.} \end{aligned}$$

Under these conditions, the tubing string is 44 inches longer due to stretch.

Chapter five discussed the buckling effect associated with slacking off tubing weight on to the packer. Buckling causes significant bending stresses in the tubing wall and as mentioned, can cause permanent damage to the tubing. The mathematics for determining the bending stress is complex and is not presented here. However, if the rules set out for loading the tubing at the beginning of this chapter are adhered to, the bending stresses should not be great enough to damage the tubing.

6



**Schlumberger**

**6**

### Tubing Anchor Calculations for Rod Pumped Wells

This chapter deals with the calculations necessary to land tubing anchors and anchor catchers in the correct amount of tension. These calculations are very important when installing anchors or anchor catchers if they are to perform their function.

In Appendix G are tables to perform these calculations and also a chart for sucker rod string weights. The tubing stretch charts referred to are found in the engineering tables section of this book.

### Mechanical Anchors Used in Rod Pumped Wells

#### Tension Tubing Anchor

This is a mechanically operated tool, using bidirectional slips to engage the casing wall to facilitate pulling tension into the tubing string. It is usually installed on the bottom of the tubing string and holds in one direction only. This type of anchor is not commonly used anymore.

#### Anchor Catcher

This is a mechanically operated tool, which uses bidirectional slips to engage the casing wall to facilitate pulling tension into the tubing string and also prevents the tubing string from moving down. The anchor catcher is the most commonly used tool for anchoring tubing and is available in right or left hand set versions. The anchor catcher has two main advantages over a tension anchor:

- It will hold parted tubing from falling down hole.
- It will hold the weight of the rod string without imposing this load on the tubing string, so long as the anchor catcher is in set position.

#### Why Anchor Your Tubing String

A well on production is pumping 12 strokes per minute with unanchored tubing; on continuous pumping this would add up to 17,280 strokes per day, approximately half a million strokes per month. Let's examine what happens on each stroke cycle:



Camco Model 'C-1'  
Anchor Catcher

Figure 7.1

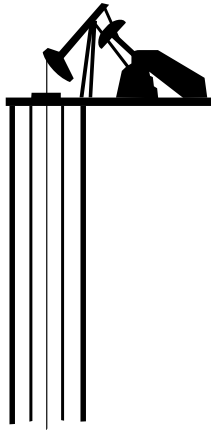

**Tubing Stretches On Downward Stroke**

Figure 7.2

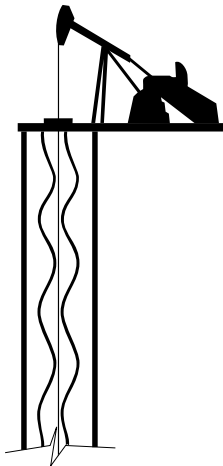

**Tubing Buckles On Upward Stroke**

Figure 7.3

## Tubing Breathing

On the downstroke, the fluid load is against the standing valve, which temporarily places an additional load on the tubing string and causes it to stretch or breath downward. On the upstroke, the fluid load is transferred from the tubing string to the sucker rod string. As the tubing string is relieved of this load, it contracts or breaths upward.

Breathing of the tubing string has several undesirable results:

- It actually shortens the pump stroke, thereby decreasing production.
- The tubing movement causes casing wear and coupling leakage.
- It can also cause tubing fatigue failures.

## Tubing Buckling

On the upstroke, tubing buckling will occur. (The tendency of tubing to bend because of internal pressure.) The fluid load is supported by the sucker rods on the upstroke and consequently, there is insufficient tension in the tubing string to prevent buckling caused by the internal pressure of the fluid in the tubing. In effect what happens is, the tubing string wraps itself around the taut rod string. Buckling begins immediately above the pump and diminishes up the string (see illustration) until a point is reached where tubing tension becomes great enough to eliminate it entirely.

On the downstroke, when the standing valve is closed, the entire weight of the fluid is transferred from the sucker rods to the tubing string (adding tension to the tubing string). Even though the tubing pressure (the cause of buckling) has not changed, there is no buckling, because of the added tubing tension.

Undesirable effects of tubing buckling:

- As the tubing buckles, it rubs against the sucker rods, causing rod wear and tubing wear which can result in failure of tubing or rods.
- The friction caused by the rod to tubing contact increase power requirements on surface.
- The buckled tubing can also make contact with the casing causing wear.
- The buckling action forces the rods out of alignment with the pump causing excessive pump wear.

# Schlumberger

## Damage from Tubing Buckling

Referring back to the downstroke on buckling, the buckling was eliminated although tubing pressure was unchanged. This was the result of the fluid load being transferred from the sucker rod string to the tubing string which added tension onto tubing string. Thus, the amount of tension required to eliminate buckling is the tension that exists in the fully elongated free tubing string of a rod pumped well on the downstroke.

The tension required to eliminate buckling is placed in the tubing string during installation by anchoring the bottom of the tubing string to the casing wall with an anchor or anchor catcher. By anchoring the bottom of the tubing string, breathing would also be eliminated, by preventing the string from moving up (shortening) on the upstroke.

## Determining Necessary Tension

The tables included in Appendix 'G' permit the calculation of the prestrain equivalent to the distance free tubing will elongate from the time the tubing is landed until the well fluid level has been pumped down to operating level.

Tubing elongation is caused by three factors:

- Tubing string being filled by warm oil.
- Loss of tubing buoyancy caused by pumping down the annulus.
- Weight of the fluid inside the tubing when the standing valve is closed.

The tubing tension requirements calculated from these tables includes all factors.

The following formula is used with the tables:

$$F_T = F_1 + F_2 - F_3$$

$F_T$  = Total tension required in lbs.  
 $F_1$  = Result of table I in lbs.  
 $F_2$  = Result of table II in lbs.  
 $F_3$  = Result of table III in lbs.

## Example of Calculation

Well data:

Tubing size = 2<sup>3</sup>/<sub>8</sub>" O.D.  
Pump and anchor depth = 4,000 ft



Fluid level when anchor set = 3,000 ft  
Operational fluid level = 4,000 ft  
Fluid temperature at surface = 70°F  
Mean yearly temperature = 37°F

$F_1$  (from table I) = 6,300 lbs.  
 $F_2$  (from table II) = 4,050 lbs.  
 $F_3$  (from table II) = 1,220 lbs.  
 $F_T = F_1 + F_2 - F_3$   
 $F_T = 6,300 \text{ lbs} + 4,050 \text{ lbs} - 1,220 \text{ lbs.}$   
 $F_T = 9,130 \text{ lbs}$  of tension is required to  
eliminate breathing and buckling

**NOTE:** The number calculated here is minimum tension required and it is presumed the well data is accurately known. A greater prestrain than that which is calculated is usually recommended as a safety factor.

The stretch charts in the engineering tables may be used to calculate the amount of stretch in inches necessary to achieve the amount of tension required. From the preceding example we require 9,130 lbs tension on the tubing string. From the stretch chart for 2<sup>3</sup>/<sub>8</sub>" tubing, 9,130 lb of tension would require 12 inches of stretch. It is recommended the initial tubing tension be applied in inches of stretch rather than lbs of tension, because of tubing to casing friction and the inaccuracies in weight indicators.

## Tubing Loads and Shear Values

### Example Well Condition

Below is an example of a set of well conditions. This example is the basis for all calculations on the following pages:

Tubing size = 2<sup>3</sup>/<sub>8</sub>" O.D. EUE  
Tubing yield strength = 71,730 lbs  
Pump and anchor depth = 4,000 ft  
Fluid level at time anchor set = 3,000 ft  
Operating fluid level = 4,000 ft

# Schlumberger

Fluid temperature at surface	=	70°F
Mean yearly temperature	=	37°F
Tubing string weight	=	18,000 lbs
Rod string weight	=	8,000 lbs
Pump plunger size	=	1 <sup>1</sup> / <sub>2</sub> "
Weight of fluid in tubing	=	6,000 lbs (est)
Shear value of anchor catcher	=	50,000 lbs

In example problem 7-1, the required tension was found to be 9,130 lbs. ( $F_T$ ) for this well to eliminate breathing and buckling.

## 1. Shear Release:

Tension anchors and anchor catchers come with an adjustable shear release. This release is a secondary, or safety release, and is not normally used unless the anchor or anchor catcher cannot be released normally. It is common practice to run anchors and anchor catchers with a high shear value to ensure against accidental or premature shearing. If too high a shear value were to be used, it may be impossible to use the shear release, if necessary, due to the tubing load.

## 2. Tubing Loads:

The maximum anticipated tubing loads should be determined and compared with the tubing string strength to prevent damage or parting of the tubing string.

- A. Maximum and minimum tubing loads, when anchor or anchor catcher will release normally:
- The minimum load will occur on the top of the string when the initial tubing tension ( $F_T$ ) is applied. This load will be the tubing tension ( $F_T$ ) plus the weight of the tubing string.

Example:  $F_T + \text{tubing string weight} = \text{minimum load}$   
 $9,130 + 18,800 \text{ lbs.} = 27,930 \text{ lbs}$

**WARNING:** With some types of donuts the minimum load will occur when the tubing is stretched over this tension to facilitate installing the donut.

7

- The maximum load on a tension anchor will occur when the weight of the rod string is added. This weight does not affect an anchor catcher unless it is released with rods still in tubing string.

Example:

$$F_T + \text{tubing weight} + \text{rod weight} = \text{maximum load}$$

$$9,130 + 18,800 \text{ lbs} + 8,000 \text{ lbs} = 35,930 \text{ lbs.}$$

From the above calculations, it is shown there is no danger of damage to the tubing since the tubing load is well below the maximum safe tubing load of 71,730 lbs., if the tool can be released normally.

- B.** The minimum and maximum tubing loads when the anchor or anchor catcher **cannot** be released normally:
  - If the sucker rods, pump and standing valve are pulled from the well, the pull required to shear the anchor or anchor catcher would be equal to the weight of the tubing **plus** the shear value of the tool.

Example:

$$\text{Weight of tubing} + \text{shear value}$$

$$= 18,800 \text{ lbs} + 40,000 \text{ lbs}$$

$$= 58,800 \text{ lbs } \mathbf{To\ Shear\ Anchor\ Catcher}$$

- If the sucker rods are pulled, but the tubing remains trapped full of fluid, a pull equal to the weight of the tubing string **plus** the weight of the fluid in the tubing string **plus** the shear value of the tool would be required to shear the anchor catcher.

Example:

$$\text{Weight of tubing} + \text{shear value} + \text{fluid weight}$$

$$= 18,800 \text{ lbs} + 50,000 \text{ lbs} + 6,000 \text{ lbs}$$

$$= 74,800 \text{ lbs } \mathbf{To\ Shear\ Catcher}$$

# Schlumberger

In this example, it would likely be necessary to exceed the tubing yield limit to shear the tool. This could cause tubing damage or parted tubing unless a lighter shear value was originally used.

- Let us assume the worst case; the rods and pump cannot be pulled and the tubing is trapped full of fluid. The pull required to shear the anchor or the anchor catcher is the weight of the tubing string **plus** the weight of the sucker rods and pump **plus** the weight of the fluid in the tubing string **plus** the shear value of the tool.

Example:

$$\begin{aligned} & \text{Weight of tubing + shear value + fluid weight} \\ & \text{+ rods \& pump weight} \\ & = 18,800 \text{ lbs} + 50,000 \text{ lbs} + 6,000 \text{ lbs} + 8,000 \text{ lbs} \\ & = 82,800 \text{ lbs TO SHEAR TOOL} \end{aligned}$$

In this example, it is not possible to shear the tool without exceeding the tubing yield strength. From this example and the preceding one, we can assume that either a lighter shear value (if possible) or a tubing string with higher yield should have been originally installed in this well.

### 3. Minimum Shear Values:

Most anchor catchers and anchors come from the manufacturer with 50,00 to 60,000 lbs. shear value. In the preceding example well, the shear value of the anchor catcher should have been reduced to allow for all conditions in which it may have to be used. If too low a shear value is used, there is danger of prematurely shearing the tool. In Appendix G is a table giving the **minimum** recommended shear values.

**WARNING:** This table does not take into account the type of donut used. Some types require a higher tension than calculated ( $F_T$ ) to install.

7



#### 4. Using Less Than Calculated Tension:

This applies to anchor catchers only. There may be special cases where it is not possible, or is inadvisable to tension the tubing by the amount ( $F_T$ ) as determined from the tables due to poor condition of tubing or in corrosive areas. In such cases, it is recommended that ( $F_T$ ) be reduced by the fluid loads on the rods to prevent the tool from transferring from cone to cone with each pump stroke.

The "Pump Plunger Size" table in Appendix G and following formula should be used to determine the reduced initial tension to apply to the tubing for the special cases referred to above.

$$\begin{aligned} F_T - F_4 &= \text{Reduced initial tension needed} \\ F_T &= \text{Calculated tension required} \\ F_4 &= \text{From "Pump Plunger Size" in Appendix G.} \end{aligned}$$

## Glossary of Terms

<b>A</b>	- area	$(P_{ia})_{final}$	- final average tubing pressure
$A_{csg}$	- inside area of casing	$P_{iapp}$	- applied tubing pressure
$A_i$	- inside area of tubing	$(P_{iapp})_{initial}$	- initial applied tubing pressure
$A_o$	- outside area of tubing	$(P_{iapp})_{final}$	- final applied tubing pressure
$A_p$	- packer seal bore area, packer valve area	$P_{ihyd}$	- tubing hydrostatic pressure
$A_s$	- tubing wall cross sectional area	$(P_{ihyd})_{initial}$	- initial tubing hydrostatic pressure
<b>BHT</b>	- bottom hole temperature	$(P_{ihyd})_{final}$	- final tubing hydrostatic pressure
<b>e</b>	- natural logarithm base (2.71828)	$P_o$	- total annulus pressure at depth of packer
<b>E</b>	- modulus of elasticity of steel (30,000,000 psi)	$(P_o)_{initial}$	- initial total annulus pressure at depth of packer
<b>F</b>	- force	$(P_o)_{final}$	- final total annulus pressure at depth of packer
$F_a$	- force at point <i>a</i>	$(P_o)_{release}$	- total annulus pressure at depth of packer when releasing
	- net force on end of tubing string	$P_{oa}$	- average total tubing pressure
$F_b$	- force at point <i>b</i>	$(P_{oa})_{initial}$	- initial average annulus pressure
$F_i$	- upward force on packer due to tubing pressure	$(P_{oa})_{final}$	- final average annulus pressure
$F_n$	- net force on packer	$P_{oapp}$	- applied annulus pressure
$F_o$	- downward force on packer due to annulus pressure	$(P_{oapp})_{initial}$	- initial applied annulus pressure
$F_p$	- packer to tubing force	$(P_{oapp})_{final}$	- final applied annulus pressure
$F_1$	- piston effect force	$P_{ohyd}$	- annulus hydrostatic pressure
$F_2$	- ballooning effect force	$(P_{ohyd})_{initial}$	- initial annulus hydrostatic pressure
$F_4$	- temperature effect force	$(P_{ohyd})_{final}$	- final annulus hydrostatic pressure
<b>fg</b>	- fluid gradient	<b>Q</b>	- volumetric flow rate
<b>h</b>	- true vertical depth	<b>r</b>	- radial clearance between tubing O.D. and casing I.D.
<b>H</b>	- height	<b>R</b>	- ratio of tubing O.D. to tubing I.D.
<b>I</b>	- moment of inertia	$S_p$	- (emergency) packer shear release value
<b>L</b>	- length	<b>T</b>	- temperature
$L_n$	- length of tubing string <i>n</i>	$T_{avg}$	- average (tubing) temperature
<b>P</b>	- pressure	$T_{sur}$	- surface temperature
$P_{app}$	- applied pressure	<b>W</b>	- weight
$P_{hyd}$	- hydrostatic pressure	$W_{air}$	- weight of tubing string in air
$P_i$	- total tubing pressure at depth of packer	$W_{hl}$	- hook-load
$(P_i)_{initial}$	- initial total tubing pressure at depth of packer	$W_i$	- linear weight of fluid in tubing in lbs/in
$(P_i)_{final}$	- final total tubing pressure at depth of packer	$W_o$	- linear weight of fluid in annulus in lbs/in
$(P_i)_{release}$	- total tubing pressure at depth of packer when releasing	$W_s$	- linear weight of tubing string in lbs/in
$P_{ia}$	- average total tubing pressure	<b>DL</b>	- length change
$(P_{ia})_{initial}$	- initial average tubing pressure	$DL_T$	- total length change due to various effects
		$DL_1$	- length change due to piston effect

## *Glossary of Terms*

$DL_2$	- length change due to ballooning effect	$DT$	- change in average tubing temperature
$DL_3$	- length change due to buckling effect	$b$	- coefficient of thermal expansion of steel (.0000069 in/in/°F)
$DL_4$	- length change due to temperature effect	$S$	- sum
$DP$	- change in total pressure	$p$	- pi (3.14159)
$DP_i$	- change in total tubing pressure at depth of packer	$r$	- density
$DP_{ia}$	- change in average tubing pressure	$\downarrow$	- pump strokes per minute
$DP_o$	- change in total annulus pressure at depth of packer	$w$	- linear weight per foot of tubing string
$DP_{oa}$	- change in average annulus pressure	$w_n$	- linear weight per foot of tubing string $n$

**Schlumberger**

**Appendix A  
TUBING DATA**





## Tubing Dimensional Data

Nominal Size (in.)	Tubing Size			Inside Diameter (in.)	Drift Diameter (in.)	Wall Thickness (in.)	Outside Area A <sub>O</sub> (sq. in.)	Inside Area A <sub>I</sub> (sq. in.)	Cross Sectional Area A <sub>S</sub> (sq. in.)	Moment of Inertia - I (in. <sup>4</sup> )	Ratio of O.D. to I.D. - R
	Outside Diameter (in.)	Weight with Couplings (lb/ft)									
		Non Upset	Upset								
3/4	1.050	1.14	1.20	.824	.730	.113	.866	.533	.333	.037	1.274
		-	1.50	.742	.730	.154		.432	.434	.045	1.415
1	1.315	1.70	1.72	1.049	.955	.133	1.358	.864	.494	.087	1.253
		-	2.25	.957	.848	.179		.719	.639	.106	1.374
1 1/4	1.660	-	-	1.410	1.286	.125	2.164	1.561	.603	.179	1.177
		2.30	2.40	1.380	1.286	.140		1.496	.663	.195	1.203
		-	-	1.278	1.184	.191		1.283	.881	.242	1.299
1 1/2	1.900	-	-	1.650	1.516	.125	2.835	2.138	.697	.276	1.152
		2.75	2.90	1.610	1.516	.145		2.036	.799	.310	1.180
2	2.00	-	-	1.500	1.406	.200	3.142	1.767	1.068	.391	1.267
		3.40	-	1.670	1.576	.165		2.190	.952	.404	1.198
2 1/16	2.063	-	-	1.751	1.657	.156	3.343	2.408	.935	.428	1.178
		4.00	-	2.041	1.947	.167		3.272	1.158	.710	1.164
2 3/8	2.375	4.70	4.70	1.995	1.901	.190	4.430	3.126	1.304	.784	1.190
		-	-	1.939	1.845	.218		2.853	1.477	.868	1.225
		5.95	5.95	1.867	1.773	.254		2.738	1.692	.965	1.272
		-	-	1.853	1.759	.261		2.697	1.733	.983	1.282
2 7/8	2.875	-	-	1.703	1.609	.336	6.492	2.152	1.149	1.149	1.395
		6.40	6.50	2.441	2.347	.217		4.680	1.812	1.611	1.178
		-	-	2.323	2.229	.276		4.238	2.254	1.924	1.238
		8.70	8.70	2.259	2.165	.308		4.008	2.484	2.075	1.273
2 7/8	2.875	-	-	2.195	2.101	.340	6.492	3.784	2.708	2.214	1.310
		-	-	2.091	1.997	.392		3.434	3.058	2.415	1.375
-	-	-	-	2.065	1.971	.405	-	3.349	3.143	2.461	1.392

**A**

**Tubing Dimensional Data**

Nominal Size (in.)	Outside Diameter (in.)	Tubing Size			Inside Diameter (in.)	Drift Diameter (in.)	Wall Thickness (in.)	Outside Area $A_o$ (sq. in.)	Inside Area $A_i$ (sq. in.)	Cross Sectional Area $A_s$ (sq. in.)	Moment of Inertia - I (in. <sup>4</sup> )	Ratio of O.D. to I.D. - R
		Weight with Couplings (lb/ft)										
		Non Upset	Upset	Integral Joint								
3 1/2	3.500	7.70	-	-	3.068	2.943	.216	9.621	7.393	2.228	3.017	1.141
		9.20	9.30	9.30	2.992	2.867	.254		7.031	2.590	3.432	1.170
		10.20	-	10.30	2.922	2.797	.289		6.706	2.555	3.788	1.198
		-	-	12.80	2.764	2.639	.368		6.000	3.621	4.501	1.266
		12.70	12.95	12.95	2.750	2.625	.375		5.940	3.681	4.559	1.273
		-	-	15.80	2.548	2.423	.476		5.099	4.522	5.297	1.374
4	4.000	-	-	16.70	2.480	2.355	.510	12.566	4.831	4.790	5.509	1.411
		9.5	-	-	3.548	3.423	.226		9.887	2.679	4.788	1.127
		-	11.00	11.00	3.476	3.351	.262		9.490	3.076	5.400	1.151
		-	-	11.60	3.428	3.303	.286		9.229	3.337	5.788	1.167
		-	-	13.40	3.340	3.215	.330		8.762	3.804	6.458	1.198
		12.50	12.75	12.75	3.958	3.833	.271		12.304	3.600	8.082	1.137
4 1/2	4.500	-	-	13.50	3.920	3.795	.290	15.904	12.068	3.836	8.538	1.148
		-	-	15.50	3.826	3.701	.337		11.497	4.407	9.610	1.176
		-	-	19.20	3.640	3.515	.430		10.406	5.498	11.512	1.236
		-	-	-	-	-	-		-	-	-	-

## Dimensional Data on Selected Heavy Weight and Non-API Tubing

O.D. in.	Weight lb/ft		Tubular			Type of Connection	Connection			Inter- changeable With**	
	Plain End	Nom.	Wall in.	I.D. in.	Drift in.		I.D.* in.	Regular			Special O.D. in.
								O.D.	in.		
1.050	1.13	1.20	.113	.824	.730	GST Streamline	1.310	1.310	1.300		
						Hydril CS, Atlas Bradford ST-C MINI-VAM	.687	1.327	1.300		
	1.47	1.50	.154	.742	.648	Hydril CS, Atlas Bradford ST-C MINI-VAM	.807	1.299			
1.315						Atlas Bradford DS-HT	.687	1.327		***	
						Atlas Bradford DSS-HT & IJ-3SS	.728	1.339		***	
	1.68	1.80	.133	1.049	.955	GST Streamline	1.551	1.551		***	
						Atlas Bradford IJ-3S	.985	1.551	1.525		
						Hydril CS, Atlas Bradford ST-C MINI-VAM	.970	1.552			
						MINI-VAM	1.004	1.555			
1.660	2.17	2.25	.179	.957	.848	Atlas Bradford DSS-HT	.849	1.600			
						Hydril CS, Atlas Bradford ST-C MINI-VAM	.864	1.600			
						MINI-VAM	.906	1.614			
						Atlas Bradford DS-HT	1.889	1.889		***	
						Atlas Bradford DSS-HT & IJ-3SS	1.301	1.893		***	
						Atlas Bradford IJ-3S	1.301	1.889		***	
	2.27	2.40	.140	1.380	1.286	GST Streamline	1.880	1.880		CS	
						Hydril A-95	1.300	1.898	1.858		
						HYdril CS, Atlas Bradford ST-C MINI-VAM	1.300	1.883	1.858	A-95	
						MINI-VAM	1.307	1.913			
	2.99	3.02	.191	1.278	1.184	Hydril CS, Atlas Bradford ST-C	1.218	1.927		A-95	
						MINI-VAM	1.205	1.976			
	3.09	3.24	.198	1.264	1.170	Hydril CS	1.200	1.927		A-95	



**Dimensional Data on Selected Heavy Weight and Non-API Tubing**

O.D. in.	Weight lb/ft		Tubular			Type of Connection	Connection			Inter- changeable With**
	Plain End	Nom.	Wall in.	I.D. in.	Drift in.		I.D.* in.	Regular O.D. in.	Special O.D. in.	
1.900						Atlas Bradford DS-HT	2.125			***
						Atlas Bradford DSS-HT & IJ-3SS	2.123			***
						Atlas Bradford IJ-3S	2.125			***
	2.75	2.90	.145	1.610	1.516	GST Streamline	2.110			
						Hydril A-95	2.134	2.094		CS
						Hydril CS, Atlas Bradford ST-C	2.113	2.094		A-95
						Mannesman Omega MINI-VAM	2.039 2.142			
2.000	3.63	3.64	.200	1.500	1.406	Hydril CS, Atlas bradford ST-C MINI-VAM	2.162 2.220			A-95
	3.93	4.19	.219	1.462	1.368	Hydril CS	2.179			A-95
	3.23	3.40	.165	1.670	1.576	National Buttress Pittsburgh 8 Acme	2.500 2.500	2.300 2.300		
2.063						Atlas Bradford DS-HT	2.320			***
		3.40				Atlas Bradford DSS-HT & IJ-3SS	2.340			***
						Atlas Bradford IJ-3S	2.320			***
	3.18		.156	1.750	1.656	GST Streamline	2.310			
						Hydril A-95	2.325	2.300		CS
						Hydril CS, Atlas Bradford ST-C MINI-VAM	2.330 2.331	2.300 2.300		A-95
4.41		4.50	.225	1.613	1.519	Hydril CS, Atlas Bradford ST-C VAM MINI-VAM	2.460 2.447 2.433	2.407		A-95

## Dimensional Data on Selected Heavy Weight and Non-API Tubing

O.D. in.	Weight lb/ft		Tubular			Type of Connection	Connection			Inter- changeable With**
	Plain End	Nom.	Wall in.	I.D. in.	Drift in.		I.D.* in.	Regular O.D. in.	Special O.D. in.	
		4.47				Atlas Bradford DS-HT	2.700		***	
		4.6				Hydril Super FJ	1.945	2.437		4.6 lb FJ
						Interlock Seal-Lock PC		2.875		
						Buttress & 8 Acme		2.875	2.700	
						Mannesman MAT		2.875		
						Mannesman TDS		2.875	2.700	
						Mannesman Omega	1.988	2.551		
						VAM	1.929	2.697	2.618	New VAM
						VAM AF	1.929	2.854		New VAM
						New VAM		2.707	2.628	VAM/AF/AG
						VAM ACE		2.697	2.618	
2.375	4.43		.190	1.950	1.901	Atlas Bradford DSS-HT, IJ-3SS & IJ-4S	1.945	2.710	***	
						Atlas Bradford IJ-3S	1.935	2.700		
						Atlas Bradford TC-4S		2.750	IJ-4S	
						Atlas Bradford FL-3S & FL-4S	1.926	2.375		
						Atlas Bradford ST-L	1.920	2.375		
						Interlock TC Nu-Lock	1.950	2.875		
						Interlock IJ Nu-Lock	1.948	2.700		
						Extreme Line	1.935	3.000		
		4.7				GST Streamline		2.700		
						Hydril A-95	1.945	2.700	CS	
						Hydril CS, Atlas Bradford ST-C	1.945	2.700	A-95	
						Hydril CFJ-P	1.945	2.525	5.3 CFJ-P	
						NKK NK-2SC		3.000	2.906	



# A

## Dimensional Data on Selected Heavy Weight and Non-API Tubing

O.D. in.	Weight lb/ft		Tubular			Type of Connection	Connection			Inter- changeable With**
							I.D.* in.	Regular O.D. in.	Special O.D. in.	
	Plain End	Nom.	Wall in.	I.D. in.	Drift in.					
2.375	5.01	5.1	.218	1.939	1.845	VAM	1.929	2.697	2.618	New VAM
						VAM AF	1.929	2.854		New VAM
		New VAM					2.736	2.628	VAM/AF/AG	
		VAM ACE					2.776	2.618		
		5.2				Interlock Seal-Lock PC	1.939	2.875		
	5.3					Atlas Bradford	1.890	2.710		***
						DSS-HT, IJ-3SS & IJ-4S		2.750		
						Atlas Bradford TC-4S	1.892	2.750		
						Interlock IJ Nu-Lock	1.890	2.750	2.700	A-95
						Hydril CS, Atlas Bradford ST-C	1.890	2.525		4.7 CFJ-P
Hydril CFJ-P							3.000	2.906		
5.75					Interlock Seal-Lock PC	1.867	2.875			
					Mannesman MAT	1.867	2.875			
					Mannesman TDS	1.867	2.875	2.700		
					Mannesman Omega	1.867	2.614			
					NKK NK-2SC		3.000	2.906	New VAM	
					VAM	1.929	2.776	2.697		
					VAM AF	1.929	2.854		New VAM	
					New VAM		2.785	2.707	VAM/AF/AG	
					VAM ACE		2.776	2.697		
					Atlas Bradford					
5.95					DSS-HT, IJ-3SS & IJ-4S	1.805	2.910		***	
					Atlas Bradford TC-4S		2.800		IJ-4S	
					Atlas Bradford FL-3S & FL-4S	1.823	2.375			

## Dimensional Data on Selected Heavy Weight and Non-API Tubing

O.D. in.	Weight lb/ft		Tubular			Type of Connection	Connection			Inter- changeable With**
	Plain End	Nom.	Wall in.	I.D. in.	Drift in.		I.D.* in.	Regular O.D. in.	Special O.D. in.	
2.375	5.75	5.95	.254	1.867	1.773	Atlas Bradford ST-L Interlock IJ Nu-Lock Extreme Line Hydril PH-6, Atlas Bradford ST-F	1.0789 1.820 1.807 1.805	2.375 2.800 3.000 2.906		
	5.89	6.2	.261	1.853	1.759	Atlas Bradford DSS-HT, IJ-3SS & IJ-4S Atlas Bradford TC-4S Hydril PH-6	1.795 1.795 1.866	2.910 2.800 2.937 2.953		*** IJ-4S
	6.26	6.3	.280	1.815	1.721	VAM AF Atlas Bradford FL-3S & FL-4S	1.771			
		7.3				VAM AF	1.866	2.953		
	7.3	7.7	.336	1.703	1.609	Atlas Bradford DSS-HT, IJ-3SS & IJ-4S Atlas Bradford TC-4S Hydril PH-6	1.645 1.645	3.135 2.900 3.125	2.924	*** IJ-4S
						Interlock Seal-Lock Hydril Super FJ Mannesman MAT Mannesman Omega	2.375	3.500 2.968 3.500 3.079	3.220	
	6.16	6.4	.217	2.441	2.347	Mannesman TDS National Buttress Pittsburgh 8 Acme VAM		3.500 3.500 3.500	3.220 3.220	New VAM New VAM
						VAM AF New VAM	2.375 2.375	3.197 3.425 3.240	3.159	New VAM New VAM VAM/AF/AG

A

# A

## Dimensional Data on Selected Heavy Weight and Non-API Tubing

O.D. in.	Weight lb/ft		Tubular			Type of Connection	Connection			Inter- changeable With**
	Plain End	Nom.	Wall in.	I.D. in.	Drift in.		I.D.* in.	Regular O.D. in.	Special O.D. in.	
2.875		6.4				VAM ACE	3.230	3.142		***
						Atlas Bradford DS-HT	3.218			***
						Atlas Bradford				***
						DSS-HT, IJ-3SS & IJ-4S	2.379			***
						Atlas Bradford IJ-3S	2.379			***
						Atlas Bradford FL-3S & FL-4S	2.372			
						Atlas Bradford ST-L	2.377			
						Atlas Bradford TC-4S	3.500	3.250		IJ-4S
		6.5		.217	2.441	2.347	Interlock TC Nu-Lock	3.500	3.220	
						Interlock IJ Nu-Lock	2.396			
						Extreme Line	2.394			
						GST Streamline	2.381			
						Hydril A-95	2.375			
						Hydril CS, Atlas Bradford ST-C	2.371			CS
						Hydril CFJ-P	2.375			A-95
						NKK NK-2SC	3.500			
						Interlock Seal-Lock PC	3.500			
						VAM	2.374			New VAM
						VAM AF	2.374			New VAM
		6.48		.276	2.323	2.229	New VAM	3.337	3.274	VAM/AF/AG
						VAM ACE	3.327	3.230		
						Mannesman MAT	3.500			
						Mannesman TDS	3.500			
						Atlas Bradford				
						DSS-HT, IJ-3SS & IJ-4S	2.265		***	

## Dimensional Data on Selected Heavy Weight and Non-API Tubing

O.D. in.	Weight lb/ft		Tubular			Type of Connection	Connection			Inter- changeable With**	
	Plain End	Nom.	Wall in.	I.D. in.	Drift in.		I.D.* in.	Regular			Special O.D. in.
								O.D.	in.		
2.875	6.48	7.9	.276	2.323	2.229	Atlas Bradford FL-3S & FL-4S	2.279	2.875		IJ-4S	
						Atlas Bradford ST-L	2.247	2.875			
						Atlas Bradford TC-4S		3.500	3.375		
						Interlock IJ Nu-Lock	2.276	3.375	3.312		
						Hydril PH-6, Atlas Bradford ST-P	2.265	3.437	3.500		
	NKK NK-2SC		3.626	3.500							
	8.6					Interlock Seal-Lock PC		3.500			New VAM New VAM VAM/AF/AG
						Mannesman MAT		3.500			
						Mannesman TDS		3.500			
						Mannesman Omega VAM	2.323	3.154	3.327		
VAM AF New Vam VAM ACE						2.323	3.425	3.364	3.274 3.264		
8.44		.308	2.259	2.165	Atlas Bradford					***	
					DSS-HT, IJ-3SS & IJ-4S	2.2	3.510				
					Atlas Bradford FL-3S & FL-4S	2.215	2.875				
					Atlas Bradford ST-L	2.196	2.875				
					Atlas Bradford TC-4S		3.500	3.375			
					Interlock IJ Nu-Lock	2.212	3.375	3.625			
					Extreme Line	2.199	3.625				
					Hydril PH-6, Atlas Bradford ST-P	2.200	3.500				
					NKK NK-2SC	3.626	3.500				
					Atlas Bradford						
9.87	9.5	.340	2.195	2.101	Atlas Bradford	2.133	3.365				
					DSS-HT, IJ-3SS & IJ-4S						



# A

## Dimensional Data on Selected Heavy Weight and Non-API Tubing

O.D. in.	Weight lb/ft		Tubular			Type of Connection	Connection			Inter- changeable With**					
							Plain End	Nom.	Wall in.		I.D. in.	Drift in.	I.D.* in.	Regular O.D. in.	Special O.D. in.
2.875	9.78	9.5	.340	2.195	2.101	Atlas Bradford TC-4S	3.500	3.450	3.450	IJ-4S					
	10.39	10.7	.392	2.091	1.997	Interlock IJ Nu-Lock	2.148	3.450	3.419						
		10.7				Hydril PH-6, Atlas Bradford ST-P	2.130	3.625	3.419						
		10.7				Hydril PH-6	2.030	3.687	3.509						
		10.7				VAM	2.205	3.453							
		10.7				VAM AF	2.260	3.583							
		10.7				VAM ACE	3.480	3.480	3.354						
		10.66	11.0	.405	2.065	1.972	Atlas Bradford	2.003	3.760		***				
		10.66	11.0			DSS-HT, IJ-3SS & IJ-4S	2.003	3.760		IJ-4S					
		10.66	11.0			Atlas Bradford TC-4S	2.018	3.500							
3.500	11.44	11.65	.440	1.995	1.901	Interlock IJ Nu-Lock	1.948	3.500							
		11.65				Hydril PH-4	1.945	3.750							
		11.65				NKK NK-2SC	3.669	3.669							
		11.65				Atlas Bradford	1.933	3.760		***					
		11.65				DSS-HT, IJ-3SS & IJ-4S	1.933	3.760		***					
	11.44	11.65	.440	1.995	1.901	Atlas Bradford TC-4S	1.948	3.550							
	11.44	11.65	.440	1.995	1.901	Interlock IJ Nu-Lock	1.945	3.750							
	11.44	11.65	.440	1.995	1.901	Hydril PH-4	3.669	3.669							
	11.44	11.65	.440	1.995	1.901	NKK NK-2SC	3.669	3.669							
	7.57	7.7	.216	3.068	2.943	Atlas Bradford FL-3S & FL-4S	2.968	3.500							
	7.57	7.7	.216	3.068	2.943	Mannesman MAT	3.068	4.250							

## Dimensional Data on Selected Heavy Weight and Non-API Tubing

O.D. in.	Weight lb/ft		Tubular			Type of Connection	Connection			Inter- changeable With**
	Plain End	Nom.	Wall in.	I.D. in.	Drift in.		I.D.* in.	Regular O.D. in.	Special O.D. in.	
3.500	7.57	7.7	.216	3.068	2.943	Mannesman Omega	3.067	3.500		New VAM
						VAM	2.972	3.803		New VAM
						VAM AF	2.972	4.213		VAM/AF/AG
						New VAM		3.841		
						VAM ACE		3.830		
						Hydril Super FJ	2.930	3.594		10.2 FJ
						Interlock Seal-Lock PC		4.250		
						Mannesman MAT		4.250		
						Mannesman Omega		4.250		
						Mannesman TDS		4.250		
8.81		9.2				National Buttress		4.250		
						Pittsburgh 8 Acme		4.250		
						VAM		4.250		
						VAM AF	3.012	3.862		New VAM
						New VAM	3.012	4.213		VAM/AF/AG
						VAM ACE		3.900		
								3.890		
								3.875		
								3.875		
								3.875		
9.3						Atlas Bradford DS-HT		3.875		***
						Atlas Bradford		3.875		***
						DSS-HT, IJ-3SS & IJ-4S	2.920	3.875		
						Atlas Bradford IJ-3S	2.920	3.875		
						Atlas Bradford FL-3S & FL-4S	2.917	3.500		IJ-4S
						Atlas Bradford TC-4S		3.950		
						Atlas Bradford ST-L		3.500		
						Interlock TC Nu-Lock	2.947	4.250		3.865
						Interlock IJ Nu-Lock	2.927	3.900		

A



# A

## Dimensional Data on Selected Heavy Weight and Non-API Tubing

O.D. in.	Weight lb/ft		Tubular			Type of Connection	Connection			Inter- changeable With**	
							I.D.* in.	Regular O.D. in.	Special O.D. in.		
	Plain End	Nom.	Wall in.	I.D. in.	Drift in.						
3.500	8.81	9.3	.254	2.992	2.867	Extreme Line	2.907	4.250		CS A-95 10.3 CFJ-P	
						GST Streamline		3.865			
						Hydril A-95	2.920	3.905	3.805		
						Hydril CS, Atlas Bradford ST-C	2.920	3.915	3.859		
						Hydril CFJ-P	2.920	3.609			
						NKK NK-2SC	4.252	4.087			
						Hydril Super FJ	2.860	3.594		9.2 FJ	
						Interlock Seal-Lock PC		4.250			
						Mannesman MAT		4.250			
						Mannesman Omega	2.992				
					Mannesman TDS		4.250				
					NKK NK-2SC						
					VAM	2.972	3.917		New VAM		
					VAM AF	2.972	4.213		New VAM		
					New VAM		3.961	3.862	VAM/AF/AG		
					VAM ACE		3.950	3.852			
					Atlas Bradford						
					DSS-HT, I-3SS & IJ-4S	2.920	3.875		***		
					Atlas Bradford FL-3S & FL-4S	2.847	3.500				
					Atlas Bradford TC-4S		3.950		IJ-4S		
					Atlas Bradford ST-L	2.845	3.500				
					Interlock IJ Nu-Lock	2.857	3.950				
					Hydril CS, Atlas Bradford ST-C	2.878	3.955	3.914	A-95		
					Hydril CFJ-P	2.878	3.609		9.3 CFJ-P		

## Dimensional Data on Selected Heavy Weight and Non-API Tubing

O.D. in.	Weight lb/ft		Tubular			Type of Connection	Connection			Inter- changeable With**
	Plain End	Nom.	Wall in.	I.D. in.	Drift in.		I.D.* in.	Regular O.D. in.	Special O.D. in.	
	12.31	12.7	.368	2.764	2.369	Atlas Bradford FL-3S & FL-4S	2.689	3.500		15.5 FJ/SFJ
		12.8				Hydril Super FJ Hydril PH-6	2.700 2.700	3.594 4.312		
3.500		12.7	.375	2.750	2.625	Interlock Seal-Lock PC		4.250		
						Mannesman MAT	4.250			
		Mannesman Omega				4.250				
		Mannesman TDS				4.250				
		VAM				2.925	3.866			
		VAM AF				2.925	3.969			
		New VAM				4.079				
		VAM ACE				4.069	3.961			
							3.951			
	12.52	12.95				Atlas Bradford	2.687	4.260		***
						DSS-HT, IJ-3SS & IJ-4S	2.675	3.500		
						Atlas Bradford FL-3S & FL-4S		4.100		
						Atlas Bradford TC-4S		3.500		
						Atlas Bradford ST-L		4.250		
						Interlock IJ Nu-Lock				
						Extreme Line				
						Hydril CFJ	2.687	3.750		
						Hydril Super FJ	2.685	3.594		
						Hydril PH-6, Atlas Bradford ST-C	2.687	4.312	4.189	
		NKK NK-2SC		4.252	4.200					
			2.835	4.138	4.035	New VAM				
	13.6	13.7	.413	2.673	2.548	VAM AF	2.835	4.449		New VAM
						New VAM		4.138	4.045	VAM/AF/AG
						VAM ACE		4.138	4.000	



**Dimensional Data on Selected Heavy Weight and Non-API Tubing**

O.D. in.	Weight lb/ft		Tubular			Type of Connection	Connection			Inter- changeable With**		
	Plain End	Nom.	Wall in.	I.D. in.	Drift in.		I.D.* in.	Regular O.D. in.	Special O.D. in.			
3.500	14.62	15.5	.449	2.602	2.477	Atlas Bradford FL-3S & FL-4S	2.527	3.500		12.8 FJ/SFJ		
						Hydril Super FJ	2.540	3.594		4.252		
	15.37	15.8	.476	2.548	2.423	NKK NK-2SC	2.835	4.374		4.035	New VAM	
						VAM	2.835	4.138		4.045		New VAM
						VAM AF	2.835	4.449		4.035		New VAM
						New VAM	2.835	4.193		4.045		VAM/AF/AG
	15.68	5.8	.488	2.524	2.399	VAM ACE	2.470	4.200		4.035		
						Atlas Bradford		4.385				***
						DSS-HT, IJ-3SS & IJ-4S		4.200				
						Atlas Bradford TC-4S	2.489	3.500				
Atlas Bradford ST-L						2.483	4.250					
Interlock IJ Nu-Lock						2.485	3.875				12.95 CFJ	
16.28	16.7	.510	2.480	2.355	Hydril CFJ	2.485	4.500		4.367			
					Hydril PH-6, Atlas Bradford ST-C	2.485	4.500					
					VAM	2.835	4.193		4.138		New VAM	
					VAM AF	2.835	4.449				New VAM	
16.28	16.7	.510	2.480	2.355	New VAM	2.835	4.211		4.138			
					VAM ACE	2.835	4.200		4.069		VAM/AF/AG	
					Atlas Bradford DSS-HT	2.391	4.525				***	
					Atlas Bradford IJ-3SS	2.420	4.525					
					Atlas Bradford IJ-4S	2.420	4.573				TC-S	
					Atlas Bradford TC-4S	2.415	4.375				IJ-4S	
16.28	16.7	.510	2.480	2.355	Interlock IJ Nu-Lock	2.415	4.250		4.250			
					Hydril PH-4	2.406	4.500					
					Hydril PH-6	2.406	4.500		4.500			

## Dimensional Data on Selected Heavy Weight and Non-API Tubing

O.D. in.	Weight lb/ft		Tubular			Type of Connection	Connection			Inter- changeable With**
	Plain End	Nom.	Wall in.	I.D. in.	Drift in.		I.D.* in.	Regular O.D. in.	Special O.D. in.	
3.500	16.81	17.05	.530	2.440	2.315	Atlas Bradford TC-4S	4.300			
						Extreme Line	2.398	4.374		
						Hydril PH-4	2.375	4.562		
						NKK NK-2SC	4.374			
4.000	9.11	9.5	.226	3.548	3.423	Atlas Bradford FL-3S & FL-4S	3.448	4.000		
						Atlas Bradford ST-L	3.468	4.000		
						Mannesman MAT	3.548	4.750		
						Mannesman Omega	3.547	4.209		
						VAM	3.457	4.327		
						VAM AF	3.457	4.606		
						New VAM	4.348			
						VAM ACE	4.339			
						Pittsburgh 8 Acme	4.750	4.000		
						National Buttress	4.750	4.400		
10.9	10.46	10.9	.262	3.476	3.351	VAM	3.492	4.366	4.327	New VAM
						VAM AF	3.492	4.606		New VAM
						New VAM	4.407	4.407	4.327	VAM/AF/AG
						VAM ACE	4.388	4.317		
						Atlas Bradford DS-HT	4.412	4.412		
						Atlas Bradford	4.385			
11	10.46	11	.262	3.476	3.351	DSS-HT, IJ-3SS & IJ-4S	3.401	4.385		***
						Atlas Bradford IJ-3S	3.401	4.000		
						Atlas Bradford FL-3S & FL-4S	4.450	4.450		
						Atlas Bradford TC-4S	4.405	4.405	4.315	CS



**Dimensional Data on Selected Heavy Weight and Non-API Tubing**

O.D. in.	Weight lb/ft		Tubular			Type of Connection	Connection			Inter- changeable With**
	Plain End	Nom.	Wall in.	I.D. in.	Drift in.		I.D.* in.	Regular O.D. in.	Special O.D. in.	
4.000	10.46	11.0	.262	3.476	3.351	Hydril CS, Atlas Bradford ST-C	3.395	4.417	4.359	A-95
						Hydril CFJ-P	3.395	4.100		
						Hydril Super FJ	3.395	4.094		
						Mannesman MAT	3.476	4.750		
						Mannesman Omega	3.476	4.236		
	11.34	11.6	.286	3.426	3.303	Mannesman TDS	3.476	4.750	4.343	
						NKK NK-2SC	3.476	4.606	4.528	
						Atlas Bradford FL-3S & FL-4S	3.353	4.000		
	12.93	13.0				Atlas Bradford ST-L	3.347	4.000		11.0 SFJ
						Hydril Super FJ	3.350	4.094		
						VAM	3.457	4.468	4.366	New VAM
						VAM AF	3.457	4.606		New VAM
						New VAM		4.516		VAM/AF/AG
						VAM ACE		4.505		
						Atlas Bradford				
DSS-HT, UJ-3SS & UJ 4S						3.275	4.572		***	
Atlas Bradford TC-4S							4.525		IJ-4S	
Hydril Super FJ						3.260	4.094			
14.0	14.0				Hydril PH-6	3.275	4.625	4.514		
					NKK NK-2SC		4.921	4.606		
					Atlas Bradford FL-3S & FL-4S	3.265	4.000			
14.66	14.8	.380	3.240	3.115	Atlas Bradford ST-L	3.274	4.000			
					VAM		4.606		New VAM	
					VAM AF		4.764		New VAM	
					New VAM	3.346	4.606		VAM/AF/AG	
					VAM ACE		4.606			

## Dimensional Data on Selected Heavy Weight and Non-API Tubing

O.D. in.	Weight lb/ft		Tubular			Type of Connection	Connection			Inter- changeable With**
	Plain End	Nom.	Wall in.	I.D. in.	Drift in.		I.D.* in.	Regular O.D. in.	Special O.D. in.	
4.000	16.36	16.5	.430	3.140	3.015	VAM	3.346	4.606		New VAM
						VAM AF	3.346	4.764		New VAM
	18.69	19.0	.500	3.000	2.875	Atlas Bradford TC-4S	4.800	4.606		VAM/AF/AG
						Hydril PH-4, Atlas Bradford ST-P NKK NK-2SC	2.920	5.000		
4.500	22.00	22.5	.610	2.780	2.655	Hydril PH-4	2.700	5.187		
						NKK NK-2SC	4.921	4.921		
	9.4	9.5	.205	4.090	3.965	Atlas Bradford	2.705	4.885		***
						DSS-HT, IJ-3SS & IJ-4S Atlas Bradford TC-4S	4.010	5.000	4.850	IJ-4S
10.23	10.5	.224	4.052	3.927	Atlas Bradford FL-3S & FL-4S	3.990	4.500			
					Atlas Bradford ST-L	4.010	4.500			
4.500	11.35	11.6	.250	4.000	3.875	Atlas Bradford FL-3S & FL-4S	3.952	4.862	4.803	New VAM
						VAM AF	3.984	5.118		New VAM
	11.35	11.6	.250	4.000	3.875	Atlas Bradford FL-3S & FL-4S	3.925	4.862	4.862	VAM/AF/AG
						Atlas Bradford ST-L	3.984	4.862		
4.500	11.35	11.6	.250	4.000	3.875	Atlas Bradford FL-3S & FL-4S	3.925	4.500		
						Atlas Bradford ST-L	3.944	4.500		
	11.35	11.6	.250	4.000	3.875	VAM	3.984	4.862	4.803	New VAM
						VAM AF	3.984	5.118	4.803	New VAM
11.35	11.6	.250	4.000	3.875	New VAM	3.984	4.862		VAM/AF/AG	
					VAM ACE	4.862	4.862			

A

# A

## Dimensional Data on Selected Heavy Weight and Non-API Tubing

O.D. in.	Weight lb/ft		Tubular			Type of Connection	Connection			Inter- changeable With**
	Plain End	Nom.	Wall in.	I.D. in.	Drift in.		I.D.* in.	Regular O.D. in.	Special O.D. in.	
4.500		12.24	12.6			Atlas Bradford FL-3S & FL-4S	3.833	4.500	13.5 SFJ	
						Atlas Bradford ST-L	3.886	4.500		
						Hydril Super FJ	3.880	4.594		
						Mannesman MAT	3.958	5.200		
						Mannesman Omega	3.957	4.744		
						Mannesman TDS	3.958	5.200		
						National Buttress		5.200		4.920
						Pittsburgh 8 Acme		5.200		4.920
						VAM		4.862		4.803
						VAM AF		5.118		
						New VAM		4.892		
						VAM ACE		4.961		
						Atlas Bradford DS-HT		4.880		
Atlas Bradford										
DSS-HT, IJ-3SS & IJ-4S	3.883	4.940		***						
Atlas Bradford TC-4S		4.950		IJ-4S						
Hydril A-95	3.865	4.910		CS						
Hydril CS	3.865	4.920		A-95						
Hydril CFJ-P	3.865	4.609								
NKK NK-2SC		5.201		5.078						
Atlas Bradford										
DSS-HT, IJ-3SS & IJ-4S	3.845	4.940		***						
Atlas Bradford FL-3S & FL-4S	3.845	4.500								
Atlas Bradford ST-L	3.854	4.500								
Atlas Bradford TC-4S		4.950								

## Dimensional Data on Selected Heavy Weight and Non-API Tubing

O.D. in.	Weight lb/ft		Tubular			Type of Connection	Connection			Inter- changeable With**
	Plain End	Nom.	Wall in.	I.D. in.	Drift in.		I.D.* in.	Regular O.D. in.	Special O.D. in.	
4.500	13.04	13.5	.290	3.920	3.795	Hydril CS	3.840	4.955	4.890	A-95
						Hydril Super FJ	3.840	4.594		12.6 SFJ
						Mannesman MAT		5.200	5.000	
						Mannesman TDS		5.200	5.078	
						NKK NK-2SC		5.201	4.803	
						VAM	3.984	4.961		New VAM
	VAM AF	3.984	5.118		New VAM					
	14.98	15.1	.337	3.826	3.701	Atlas Bradford FL-3S & FL-4S	3.751	4.500		
						Atlas Bradford ST-L	3.776	4.500		
						Mannesman MAT	3.826	5.200	5.000	
						Mannesman TDS	3.826	5.200	4.882	
						VAM	3.933	4.961		New VAM
VAM AF						3.933	5.118		New VAM	
16.44	16.9	.373	3.754	3.629	Atlas Bradford	3.765	5.060		***	
					DSS-HT, IJ-3SS & IJ-4S	3.765	5.100		IJ-4S	
					Atlas Bradford TC-4S	3.765	5.125	5.021		
					Hydril PH-6, Atlas Bradford ST-C	3.765	5.201	5.078		
					NKK NK-2SC					
					Atlas Bradford	3.679	5.150			
DSS-HT, IJ-3SS & IJ-4S	3.679	4.500								
Atlas Bradford FL-3S & FL-4S										
Atlas Bradford TC-4S										

A



# A

## Dimensional Data on Selected Heavy Weight and Non-API Tubing

O.D. in.	Weight lb/ft		Tubular			Type of Connection	Connection			Inter- changeable With**
	Plain End	Nom.	Wall in.	I.D. in.	Drift in.		I.D.* in.	Regular O.D. in.	Special O.D. in.	
4.500	16.72	16.9	.380	3.740	3.615	VAM	3.854	5.106		New VAM
						VAM AF	3.854	5.472		New VAM
						New VAM		5.106		VAM/AF/AG
						VAM ACE		5.106		
	18.69	18.8	.430	3.640	3.515	VAM	3.854	5.106		New VAM
						VAM AF	3.854	5.472		New VAM
						New VAM		5.146		VAM/AF/AG
						VAM ACE		5.201		
						Atlas Bradford				
						DSS-HT, IJ-3SS & IJ-4S	3.565	5.260		***
Atlas Bradford ST-P	3.560	5.312		5.170						
Atlas Bradford TC-4S		5.200								
Hydril PH-6	3.560	5.312		5.170						
21.36	21.6	.500	3.500	3.375	NKK NK-2SC		5.563	5.315		
					Atlas Bradford					
					DSS-HT, IJ-3SS & IJ-4S	3.425	5.375		***	
					Atlas Beadford TC-4S	3.420	5.300			
					Hydril PH-4		5.500			
					VAM	3.854	5.201		New VAM	
					New VAM		5.280		VAM/AF/AG	
					VAM ACE		5.280			
					VAM AF	3.854	5.472		New VAM	
					NKK NK-2SC		5.563	5.315		
23.56	24.0	.560	3.380	3.255	Hydril PH-4	3.300	5.562	5.315		
					NKK NK-2SC		5.563	5.315		

## Dimensional Data on Selected Heavy Weight and Non-API Tubing

O.D. in.	Weight lb/ft		Tubular			Type of Connection	Connection			Inter- changeable With**
	Plain End	Nom.	Wall in.	I.D. in.	Drift in.		I.D.* in.	Regular O.D. in.	Special O.D. in.	
4.500	23.56	24.6	.560	3.380	3.255	VAM VAM AF New VAM VAM ACE	3.854 3.854 5.333 5.322	5.280 5.280 5.333 5.322		New VAM New VAM VAM/AF/AG
	26.04	26.5	.630	3.240	3.115	Hydril PH-4 NKK NK-2SC	3.160	5.687 5.563		

\* Joint I.D. listed only if different than tubular I.D.

\*\* U and T&C joints listed are mechanically interchangeable throughout entire weight range in each size. Flush joints are not interchangeable from one weight to another in same size except as indicated for some special Hydril weights.

\*\*\* DS-HT, DSS-HT, U-3S and U-3SS joints are mechanically interchangeable although mixed connections can render the metal-to-metal pin nose seal of the U-3S and U-3SS joints ineffective.

Atlas Bradford ST-C is interchangeable with Hydril CS.

Atlas Bradford ST-P is interchangeable with Hydril PH-6.



# A

## Tubing Sizes and Capacities

O.D. in.	Weight			I.D. in.	Gallons per Lineal Foot	Lineal Feet per Gallon	Cubic Feet per Lineal Foot	Lineal Feet per Cubic Foot	Barrels per Lineal Foot	Lineal Feet per Barrel
	NU lb/ft	EU lb/ft	IJ lb/ft							
1.050	1.14	1.20	1.20	.824	.02770	36.10	.003703	270.04	.0006595	1516
		1.50	1.50	.742	.02246	44.52	.003003	333.02	.0005348	1870
1.315	1.70	1.80	1.80	1.049	.04490	22.27	.006001	166.6	.001070	934.6
			2.25	.957	.03737	.004995	26.76	.004995	200.2	.0008896
1.660	1.30	2.40	2.10	1.410	.08111	12.33	.01084	92.22	.001931	517.9
			2.40	1.380	.07780	12.85	.01040	96.19	.001852	540.0
			3.02	1.278	.06664	15.01	.008908	112.3	.001587	630.1
1.900	2.75	2.90	2.40	1.650	.1111	9.003	.01485	67.35	.002645	378.1
			2.90	1.610	.1058	9.447	.01415	70.67	.002520	396.8
			3.64	1.500	.09180	10.89	.01227	81.49	.002186	457.5
2.000	3.40			1.670	.1138	8.787	.01521	65.75	.002709	369.1
2.063			3.25	1.751	.1251	7.994	.01672	59.80	.002979	335.7
2.375	4.00	4.70	4.70	2.041	.1700	5.884	.02272	44.01	.004047	247.1
			5.30	1.995	.1626	6.152	.02173	46.02	.003870	258.4
			5.80	1.939	.1534	6.519	.02051	48.77	.003652	273.8
			6.20	1.867	.1422	7.032	.01901	52.60	.003386	295.3
			7.70	1.853	.1401	7.138	.01873	53.39	.003336	299.8
2.875	6.40	6.50	6.50	2.441	.2433	4.109	.03253	30.74	.005794	172.6
			7.90	2.323	.2202	4.542	.02943	33.96	.005241	190.8
			8.60	2.259	.2082	4.803	.02783	35.93	.004958	201.7
			9.50	2.195	.1966	5.087	.02628	38.06	.004679	213.7
			10.70	2.091	.1784	5.606	.02385	41.93	.004248	235.4
			11.00	2.065	.1740	5.748	.02326	43.00	.004143	241.4
			11.65	1.995	.1626	6.152	.02173	46.02	.003870	258.4
3.500	7.70	9.30	9.30	3.068	.3840	2.604	.05134	19.48	.009141	109.4
			10.20	2.992	.3656	2.735	.04888	20.46	.008706	114.9
			12.80	2.922	.3487	2.868	.04661	21.46	.008301	120.5
			12.70	2.764	.3117	3.208	.04167	24.00	.007423	134.7
			15.80	2.750	.3085	3.241	.04125	24.24	.007347	136.1
			16.70	2.548	.2649	3.775	.03541	28.24	.006305	158.6
4.000	9.50	11.00	11.00	3.548	.5138	1.946	.06869	14.56	.01223	81.75
			11.60	3.476	.4935	2.027	.065597	15.16	.01175	85.12
			13.40	3.428	.4794	2.086	.06409	15.60	.01142	87.56
				3.340	.4551	2.197	.06084	16.44	.01084	92.26
4.500	12.60	12.75	12.75	3.958	.6397	1.563	.08552	11.69	.01523	65.64
			13.50	3.920	.6269	1.595	.08381	11.93	.01493	66.97
			15.50	3.826	.5972	1.674	.07984	12.53	.01422	70.32
			19.20	3.640	.5406	1.850	.07226	13.84	.01287	77.70

# Tubing Performance Properties

Nominal Size (in.)	Outside Diameter (in.)	Grade	Tubing Size				Threaded and Coupled				Integral Joint			Internal Joint Pressure*			Joint Yield Strength*		
			Weight with Couplings		Inside Diameter (in.)	Drift Diameter (in.)	Coupling Outside Diameter		Drift Diameter (in.)	Box Outside Diameter (in.)	Collapse Resistance (Pressure)* (psi)	Internal Joint Pressure* (psi)	Threaded and Coupled		Integral Joint (lb)				
			Non Upset (lb/ft)	Upset (lb/ft)			Non Upset (in.)	Upset Regular (in.)					Upset Special (in.)	Non Upset (lb)		Upset (lb)			
3/4	1.050	F-25X	-	1.20	.824	.730	-	1.660	-	-	-	-	4,710	-	8,320	-			
		H-40	1.14	1.20	.824	.730	1.313	1.660	-	-	-	-	7,530	6,360	13,310	-			
		J-55	1.14	1.20	.824	.730	1.313	1.660	-	.648	1.327	10,560	10,360	8,740	18,290	18,000			
		C-75	1.14	1.20	.824	.730	1.313	1.660	-	.648	1.327	14,410	14,120	11,920	24,950	25,000			
		N-80	1.14	1.20	.824	.730	1.313	1.660	-	.648	1.327	15,370	15,070	12,710	26,610	27,000			
		D-55X	-	1.50	.742	.648	-	1.339	-	.648	1.327	13,770	14,120	-	24,000	24,000			
		C-75X	-	1.50	.742	.648	-	1.339	-	.648	1.327	18,770	19,250	-	33,000	33,000			
		N-80X	-	1.50	.742	.648	-	1.339	-	.648	1.327	20,020	20,530	-	35,000	35,000			
		P-105X	-	1.50	.742	.648	-	1.339	-	.648	1.327	26,280	26,950	-	46,000	46,000			
		F-25X	-	1.80	1.049	.955	-	1.900	-	-	-	5,540	4,430	-	12,350	-			
1	1.315	H-40	1.70	1.80	1.049	.955	1.660	1.900	-	.955	1.550	7,270	7,080	10,960	19,760	15,970			
		J-55	1.70	1.80	1.049	.955	1.660	1.900	-	.955	1.550	10,000	9,730	15,060	27,160	21,960			
		J-55X	-	-	.957	-	-	-	-	.848	1.600	12,940	13,100	-	-	35,000			
		C-75	1.70	1.80	1.049	.955	1.660	1.900	-	.955	1.550	13,640	13,270	20,540	37,040	29,940			
		C-75X	-	-	.957	-	-	-	-	.848	1.600	17,640	17,870	-	-	48,000			
		N-80	1.70	1.80	1.049	.955	1.660	1.900	-	.955	1.550	14,550	14,160	21,910	39,510	31,940			
		N-80X	-	-	.957	-	-	-	-	.848	1.600	18,820	19,060	-	-	51,000			
		P-105X	-	-	.957	-	-	-	-	.848	1.600	24,700	25,010	-	-	67,000			
		F-25X	-	2.40	1.380	1.286	-	2.200	-	-	-	4,440	3,690	-	16,710	-			
		H-40	-	-	1.410	-	-	-	-	1.286	1.880	5,270	5,270	-	-	22,180			
1/4	1.660	H-40	2.30	2.40	1.380	1.286	2.054	2.200	-	1.286	1.880	6,180	5,900	15,530	26,740	22,180			
		J-55	-	-	1.410	-	-	-	1.286	1.880	7,660	7,250	-	-	30,500				
		J-55	2.30	2.40	1.380	1.286	2.054	2.200	-	1.286	1.880	8,490	8,120	21,360	36,770	30,500			
		J-55X	-	-	1.278	-	-	-	-	1.184	1.927	11,200	11,070	-	-	48,000			
		C-75	2.30	2.40	1.380	1.286	2.054	2.200	-	1.286	1.880	11,580	11,070	29,120	50,140	41,600			

\* Collapse resistance, internal yield pressure, body yield strength, and joint yield strength are minimum values with no safety factor.  
 x Not API standard, it is shown for information only.





## Tubing Performance Properties

Nominal Size (in.)	Outside Diameter (in.)	Grade	Tubing Size				Threaded and Coupled				Integral Joint		Joint Yield Strength*					
			Weight with Couplings		Inside Diameter (in.)	Drift Diameter (in.)	Coupling Outside Diameter		Upset Special (in.)	Collapse Resistance (Pressure)* (psi)	Internal Joint Pressure* (psi)	Threaded and Coupled		Integral Joint (lb)				
			Non Upset (lb/ft)	Upset (lb/ft)			Integral Joint (lb/ft)	Non Upset (in.)				Upset Regular (in.)	Non Upset (lb)		Upset (lb)			
1 1/4	1.660	C-75 <sup>x</sup>	-	-	3.02	1.278	-	-	-	-	1.184	1.927	15,270	15,100	-	-	66,000	
		N-80	2.30	2.40	2.33	1.380	1.286	2.054	2.200	-	1.286	1.880	12,360	11,810	31,060	53,480	44,370	
		N-80 <sup>x</sup>	-	-	3.02	1.278	-	-	-	-	1.184	1.927	16,290	16,110	-	-	71,000	
		P-105 <sup>x</sup>	-	-	3.02	1.278	-	-	-	-	1.184	1.927	21,380	21,140	-	-	93,000	
1 1/2	1.900	F-25 <sup>x</sup>	2.75	2.90	-	1.610	1.516	2.200	2.500	-	-	-	-	3,920	3,340	11,930	19,990	-
		H-40	-	-	2.40	1.650	-	-	-	-	1.516	2.110	4,920	4,610	-	-	26,890	
		H-40	2.75	2.90	2.76	1.610	1.526	2.200	2.500	-	1.516	2.110	5,640	5,340	19,090	31,980	26,890	
		J-55	-	-	2.40	1.650	-	-	-	-	1.516	2.110	6,640	6,330	-	-	36,970	
		J-55	2.75	2.90	2.76	1.610	1.516	2.200	2.500	-	1.516	2.110	7,750	7,350	26,250	43,970	36,970	
		J-55 <sup>x</sup>	-	-	3.64	1.500	-	-	-	-	1.406	2.162	10,360	10,130	-	-	57,000	
		C-75	2.75	2.90	2.76	1.610	1.516	2.200	2.500	-	1.516	2.110	10,570	10,020	35,800	59,960	50,420	
		C-75 <sup>x</sup>	-	-	3.64	1.500	-	-	-	-	1.406	2.162	14,130	13,820	-	-	80,000	
2	2.000	N-80	2.75	2.90	2.76	1.610	1.516	2.200	2.500	-	1.516	2.110	11,280	10,680	38,180	63,960	53,780	
		N-80 <sup>x</sup>	-	-	3.64	1.500	1.406	-	-	-	1.406	2.162	15,070	14,740	-	-	84,000	
		P-105 <sup>x</sup>	-	-	3.64	1.500	-	-	-	-	1.406	2.162	19,780	19,340	-	-	110,000	
		J-55 <sup>x</sup>	3.40	-	-	1.670	1.576	2.50	-	-	-	-	-	8,320	7,940	52,320	-	-
		C-75 <sup>x</sup>	3.40	-	-	1.670	1.576	2.50	-	-	-	-	-	11,350	10,830	71,330	-	-
		N-80 <sup>x</sup>	3.40	-	-	1.670	1.576	2.50	-	-	-	-	-	12,110	11,550	76,080	-	-
2 1/16	2.063	P-105 <sup>x</sup>	3.40	-	-	1.670	1.576	2.50	-	-	-	-	15,890	15,160	99,880	-	-	
		H-40	-	-	3.25	1.751	-	-	-	-	1.657	2.325	5,590	5,290	-	-	35,690	
		J-55	-	-	3.25	1.751	-	-	-	-	1.657	2.325	7,690	7,280	-	-	49,070	
		C-75	-	-	3.25	1.751	-	-	-	-	1.657	2.325	10,480	9,920	-	-	66,910	
2 1/16	2.063	N-80	-	-	3.25	1.751	-	-	-	1.657	2.325	11,180	10,590	-	-	71,370		

\* Collapse resistance, internal yield pressure, body yield strength, and joint yield strength are minimum values with no safety factor.  
<sup>x</sup> Not API standard, it is shown for information only.

# Tubing Performance Properties

Nominal Size (in.)	Outside Diameter (in.)	Grade	Tubing Size				Threaded and Coupled				Integral Joint			Internal Joint Pressure*			Joint Yield Strength*		
			Weight with Couplings		Inside Diameter (in.)	Drift Diameter (in.)	Coupling Outside Diameter		Drift Diameter (in.)	Box Outside Diameter (in.)	Collapse Resistance (Pressure)* (psi)	Internal Joint Pressure* (psi)	Threaded and Coupled		Integral Joint (lb)				
			Non Upset (lb/ft)	Upset (lb/ft)			Non Upset (in.)	Upset Regular (in.)					Upset Special (in.)	Non Upset (lb)		Upset (lb)			
2 3/8		F-25 <sup>x</sup>	4.00	-	2.041	1.947	2.875	-	-	-	3.530	3.080	18,830	-	-	-	-		
		F-25 <sup>x</sup>	4.60	4.70	1.955	1.901	2.875	3.063	-	-	4.160	3.500	22,480	32,600	-	-	-		
		H-40	4.00	-	2.041	1.947	2.875	-	-	-	5.230	4.920	30,130	-	-	-	-		
		H-40	4.60	4.70	1.955	1.901	2.875	3.063	2.910	-	5.890	5.600	35,960	52,170	-	-	-		
		J-55	4.00	-	2.041	1.947	2.875	-	-	-	7.190	6.770	41,430	-	-	-	-		
		J-55	4.60	4.70	1.995	1.901	2.875	3.063	2.910	1.901	8.100	7.700	49,450	71,730	72,000	-	-		
		J-55 <sup>x</sup>	-	-	1.939	-	-	-	-	1.845	9.170	8.840	-	-	81,000	-	-		
		J-55 <sup>x</sup>	-	-	1.853	-	-	-	-	1.759	10.760	10.580	-	-	95,000	-	-		
		J-55 <sup>x</sup>	4.00	-	2.041	1.947	2.875	-	-	-	13.360	13.620	-	-	118,000	-	-		
		C-75	4.60	4.70	1.995	1.901	2.875	3.063	2.910	1.901	11.040	10.500	67,430	97,820	98,000	-	-		
		C-75 <sup>x</sup>	-	-	1.939	-	-	-	-	1.845	12.510	12.050	-	-	111,000	-	-		
		C-75	5.80	5.95	1.867	1.773	2.875	3.063	2.910	1.867	14.330	14.040	96,560	126,940	127,000	-	-		
		C-75 <sup>x</sup>	-	-	1.853	-	-	-	-	1.759	14.670	14.420	-	-	130,000	-	-		
		C-75 <sup>x</sup>	-	-	1.703	-	-	-	-	1.609	18.220	18.570	-	-	161,000	-	-		
		N-80	4.00	-	2.041	1.947	2.875	-	-	-	9.980	9.840	60,260	-	-	-	-		
		N-80	4.60	4.70	1.995	1.901	2.875	3.063	2.910	1.901	11.780	11.200	71,930	104,304	104,000	-	-		
		N-80 <sup>x</sup>	-	-	1.939	-	-	-	-	1.845	13.340	12.860	-	-	118,000	-	-		
		N-80	5.80	5.95	1.867	1.773	2.875	3.063	2.910	1.867	15.280	14.970	102,990	135,400	135,000	-	-		
		N-80 <sup>x</sup>	-	-	1.853	-	-	-	-	1.759	15.650	15.390	-	-	139,000	-	-		
		N-80 <sup>x</sup>	-	-	1.703	-	-	-	-	1.609	19.430	19.810	-	-	172,000	-	-		
P-105	4.60	4.70	1.995	1.901	2.875	3.063	2.910	1.901	15.460	14.700	94,410	136,940	137,000	-	-				
P-105 <sup>x</sup>	-	-	1.939	-	-	-	-	1.845	17.510	16.870	-	-	155,000	-	-				
P-105	5.80	5.95	1.867	1.773	2.875	3.063	2.910	1.867	20.060	19.650	135,180	177,710	178,000	-	-				
P-105 <sup>x</sup>	-	-	1.853	-	-	-	-	1.759	20.540	20.200	-	-	182,000	-	-				
P-105 <sup>x</sup>	-	-	1.703	-	-	-	-	1.609	25.510	26.010	-	-	226,000	-	-				
P-110 <sup>x</sup>	4.60	4.70	1.995	1.901	2.875	3.063	2.910	1.901	13.800	15.400	98,900	143,470	-	-	-				
P-110 <sup>x</sup>	5.80	5.95	1.867	1.773	2.875	3.063	2.910	1.773	17.910	20.590	141,610	186,170	-	-	-				

\* Collapse resistance, internal yield pressure, body yield strength, and joint yield strength are minimum values with no safety factor.  
<sup>x</sup> Not API standard, it is shown for information only.





## Tubing Performance Properties

Nominal Size (in.)	Outside Diameter (in.)	Grade	Tubing Size			Threaded and Coupled				Integral Joint			Joint Yield Strength*					
			Weight with Couplings		Integral Joint (lb/ft)	Drift Diameter (in.)	Coupling Outside Diameter		Upset Special (in.)	Box Outside Diameter (in.)	Collapse Resistance (Pressure)* (psi)	Internal Joint (Burst) Pressure* (psi)	Threaded and Coupled		Integral Joint (lb)			
Non Upset (lb/ft)	Upset (lb/ft)	Non Upset (in.)	Upset Regular (in.)	Upset Regular (in.)			Upset Special (in.)	Non Upset (lb)					Upset (lb)					
2 7/8		F-25 <sup>x</sup>	6.40	6.50	—	2.441	2.347	3.500	3.668	—	—	—	3.870	3.300	32,990	45,300	—	
		H-40	6.40	6.50	—	2.441	2.347	3.500	3.668	3.460	—	—	5.580	5.280	52,780	72,480	—	
		J-55	6.40	6.50	6.50	2.441	2.347	3.500	3.668	3.460	2.347	2.347	7.680	7.260	72,580	99,660	100,000	
		J-55 <sup>x</sup>	—	—	—	7.90	2.323	—	—	—	—	2.229	3.437	9.250	—	—	124,000	
		J-55 <sup>x</sup>	—	—	—	8.70	2.259	—	—	—	—	2.165	3.500	10.530	—	—	137,000	
		J-55 <sup>x</sup>	—	—	—	9.50	2.195	—	—	—	—	2.101	3.625	11.470	—	—	149,000	
		J-55 <sup>x</sup>	—	—	—	10.70	2.091	—	—	—	—	1.997	3.687	12.960	—	—	168,000	
		J-55 <sup>x</sup>	—	—	—	11.00	2.065	—	—	—	—	1.971	3.750	13.310	—	—	173,000	
		C-75	6.40	6.50	6.50	2.441	2.347	3.500	3.668	3.460	2.347	2.347	2.229	3.437	9.910	98,970	135,900	136,000
		C-75 <sup>x</sup>	—	—	—	7.90	2.323	—	—	—	—	2.229	3.437	13.020	—	—	169,000	
		C-75	8.60	8.70	8.70	2.259	2.165	3.500	3.668	3.460	2.165	2.165	2.165	14.350	14.060	149,360	186,290	186,000
		C-75 <sup>x</sup>	—	—	—	9.50	2.195	—	—	—	—	2.101	3.625	15.640	—	—	203,000	
		C-75 <sup>x</sup>	—	—	—	10.70	2.091	—	—	—	—	1.997	3.687	17.670	—	—	229,000	
		C-75 <sup>x</sup>	—	—	—	11.00	2.065	—	—	—	—	1.971	3.750	18.150	—	—	236,000	
		N-80	6.40	6.50	6.50	2.441	2.347	3.500	3.668	3.460	2.347	2.347	2.229	3.437	10.570	105,570	144,960	145,000
		N-80 <sup>x</sup>	—	—	—	7.90	2.323	—	—	—	—	2.229	3.437	13.890	—	—	180,000	
		N-80	8.60	8.70	8.70	2.259	2.165	3.500	3.668	3.460	2.165	2.165	2.165	15.300	15.000	159,310	198,710	198,000
	N-80 <sup>x</sup>	—	—	—	9.50	2.195	—	—	—	—	2.101	3.625	16.690	—	—	217,000		
	N-80 <sup>x</sup>	—	—	—	10.70	2.091	—	—	—	—	1.997	3.687	18.850	—	—	245,000		
	N-80 <sup>x</sup>	—	—	—	11.00	2.065	—	—	—	—	1.971	3.750	19.360	—	—	251,000		
	P-105	6.40	6.50	6.50	2.441	2.347	3.500	3.668	3.460	2.347	2.347	2.229	3.437	13.870	138,560	190,260	190,000	
	P-105 <sup>x</sup>	—	—	—	7.90	2.323	—	—	—	—	2.229	3.437	18.230	—	—	236,000		
	P-105	8.60	8.70	8.70	2.259	2.165	3.500	3.668	3.460	2.165	2.165	2.165	20.090	19.690	209,100	260,810	261,000	
	P-105 <sup>x</sup>	—	—	—	9.50	2.195	—	—	—	—	2.101	3.625	21.900	—	—	285,000		
	P-105 <sup>x</sup>	—	—	—	10.70	2.091	—	—	—	—	1.997	3.687	24.740	—	—	321,000		
	P-110 <sup>x</sup>	6.40	6.50	—	2.441	2.347	3.500	3.668	—	—	—	—	13.080	14.530	145,160	199,320	—	

\* Collapse resistance, internal yield pressure, body yield strength, and joint yield strength are minimum values with no safety factor.  
<sup>x</sup> Not API standard, it is shown for information only.

# Tubing Performance Properties

Nominal Size (in.)	Outside Diameter (in.)	Tubing Size				Threaded and Coupled				Integral Joint			Joint Yield Strength*			
		Grade	Weight with Couplings		Inside Diameter (in.)	Drift Diameter (in.)	Coupling Outside Diameter		Upset Diameter (in.)	Box Outside Diameter (in.)	Collapse Resistance (Pressure)* (psi)	Internal Joint Pressure* (psi)	Threaded and Coupled		Integral Joint (lb)	
			Non Upset (lb/ft)	Integral Joint (lb/ft)			Non Upset (in.)	Upset Regular (in.)					Upset Special (in.)	Non Upset (lb)		Upset (lb)
3/2		F-25 <sup>x</sup>	7.70	-	3.068	2.943	4.250	-	-	-	2,970	2,700	40,670	-	-	
		F-25 <sup>x</sup>	9.20	9.30	2.992	2.867	4.250	4.500	-	-	3,680	3,180	49,710	64,760	-	
		F-25 <sup>x</sup>	10.20	-	2.922	2.797	4.250	-	-	-	4,330	3,610	57,840	-	-	
		H-40	7.70	-	3.068	2.943	4.250	-	-	-	4,630	4,320	65,070	-	-	
		H-40	9.20	9.30	2.992	2.867	4.250	4.500	4.180	-	5,380	5,080	79,540	103,610	-	
		H-40	10.20	-	2.922	2.797	4.250	-	-	-	6,060	5,780	92,550	-	-	
		J-55	7.70	-	3.068	2.943	4.250	-	-	-	5,970	5,940	89,470	-	-	
		J-55	9.20	9.30	2.992	2.867	4.250	4.500	4.180	2.867	3,905	6,980	109,370	142,460	142,000	
		J-55	10.20	-	2.922	2.797	4.250	-	-	2.797	3,955	7,950	127,250	-	160,000	
		J-55 <sup>x</sup>	-	-	12.80	2.764	-	-	-	-	2.639	4,312	10,350	-	-	199,000
		J-55 <sup>x</sup>	-	-	12.95	2.750	-	-	-	-	2.625	4,312	10,530	-	-	203,000
		J-55 <sup>x</sup>	-	-	15.80	2.548	-	-	-	-	2.423	4,500	12,930	-	-	249,000
		J-55 <sup>x</sup>	-	-	16.70	2.480	-	-	-	-	2.355	4,562	13,690	-	-	264,000
		C-75	7.70	-	3.068	2.943	4.250	-	-	-	-	7,540	8,100	122,010	-	-
		C-75	9.20	9.30	2.992	2.867	4.250	4.500	4.180	2.867	3,905	10,040	9,520	149,140	194,260	194,000
		C-75	10.20	-	2.922	2.797	4.250	-	-	2.797	3,955	11,360	10,840	173,530	-	219,000
		C-75 <sup>x</sup>	-	-	12.80	2.764	-	-	-	-	2.639	4,312	14,110	-	-	272,000
		C-75	12.70	12.95	2.750	2.625	4.250	4.500	4.180	2.625	4,312	14,350	14,060	230,990	276,120	276,000
		C-75 <sup>x</sup>	-	-	15.80	2.548	-	-	-	-	2.423	4,500	17,630	-	-	339,000
		C-75 <sup>x</sup>	-	-	16.70	2.480	-	-	-	-	2.355	4,562	18,670	-	-	359,000
N-80	7.70	-	3.068	2.943	4.250	-	-	-	-	7,870	8,640	130,140	-	-		
N-80	9.20	9.30	2.992	2.867	4.250	4.500	4.180	2.867	3,905	10,530	10,160	159,090	207,220	207,000		
N-80	10.20	-	2.922	2.797	4.250	-	-	2.797	3,955	12,120	11,560	185,100	-	233,000		
N-80 <sup>x</sup>	-	-	12.80	2.764	-	-	-	-	2.639	4,312	15,060	-	-	290,000		
N-80	12.70	12.95	2.750	2.625	4.250	4.500	4.180	2.625	4,312	15,310	15,000	246,390	294,530	295,000		
N-80 <sup>x</sup>	-	-	15.80	2.548	-	-	-	-	2.423	4,500	18,800	-	-	362,000		

\*Collapse resistance, internal yield pressure, body yield strength, and joint yield strength are minimum values with no safety factor.  
<sup>x</sup> Not API standard, it is shown for information only.





## Tubing Performance Properties

Nominal Size (in.)	Outside Diameter (in.)	Grade	Tubing Size				Threaded and Coupled				Integral Joint			Joint Yield Strength*					
			Weight with Couplings		Integral Joint (lb/ft)	Inside Diameter (in.)	Drift Diameter (in.)	Coupling Outside Diameter		Upset Special (in.)	Box Outside Diameter (in.)	Collapse Resistance (Pressure)* (psi)	Internal Joint (Burst) Pressure* (psi)	Threaded and Coupled		Integral Joint (lb)			
			Non Upset (lb/ft)	Upset (lb/ft)				Non Upset (in.)	Upset Regular (in.)					Non Upset (lb)	Upset (lb)				
3 1/2	3.500	N-80 <sup>x</sup>	-	-	16.70	2.480	-	-	-	-	-	2.355	4.562	19,920	20,400	-	-	383,000	
		P-105	9.20	9.30	9.30	2.992	2.867	4.250	4.500	4.180	-	2.867	3.905	13,050	13,330	208,800	271,970	272,000	
		P-105 <sup>x</sup>	-	-	10.30	2.922	-	-	-	-	-	2.797	3.955	15,920	15,180	-	-	306,000	
		P-105 <sup>x</sup>	-	-	12.80	2.764	-	-	-	-	-	2.639	4.312	19,760	19,320	-	-	380,000	
		P-105	12.70	12.95	12.95	2.750	2.625	4.250	4.500	4.180	-	2.625	2.312	20,090	19,690	323,390	386,560	387,000	
		P-105 <sup>x</sup>	-	-	15.80	2.548	-	-	-	-	-	2.423	4.500	24,680	24,990	-	-	475,000	
		P-105 <sup>x</sup>	-	-	16.70	2.480	-	-	-	-	-	2.355	4.562	26,140	26,770	-	-	503,000	
		P-110 <sup>x</sup>	9.20	9.30	-	2.992	2.867	4.250	4.500	-	-	-	-	12,620	13,970	218,740	284,920	-	
		P-110 <sup>x</sup>	12.70	12.95	-	2.750	2.625	4.250	4.500	-	-	-	-	17,940	20,630	338,790	365,570	-	
		4	4.000	F-25 <sup>x</sup>	9.50	-	-	3.548	3.423	4.750	-	-	-	-	-	-	2,630	2,470	45,000
F-25 <sup>x</sup>	-			11.00	-	3.476	3.351	-	5.000	-	-	-	-	-	3,220	2,870	-	76,920	-
H-40	9.50			-	-	3.548	3.423	4.750	-	-	-	-	-	-	4,060	3,960	72,000	-	-
H-40	-			11.00	-	3.476	3.351	-	5.000	-	-	-	-	-	4,900	4,590	-	123,070	-
J-55	9.50			-	-	3.548	3.423	4.750	-	-	-	-	-	-	5,110	5,440	99,010	-	-
J-55	-			11.00	11.00	3.476	3.351	-	5.000	-	-	3.351	4.405	6,590	6,300	-	169,220	169,000	
J-55 <sup>x</sup>	-			-	11.60	3.428	-	-	-	-	-	3.303	4.000	7,300	6,880	-	-	137,000	
C-75	9.50			-	-	3.548	3.423	4.750	-	-	-	-	-	-	6,350	7,420	135,010	-	-
C-75	-			11.00	11.00	3.476	3.351	-	5.000	-	-	3.351	4.405	8,410	8,600	-	230,760	231,000	
C-75 <sup>x</sup>	-			-	13.40	3.340	-	-	-	-	-	3.215	4.625	11,350	10,830	-	-	285,000	
N-80	N-80	N-80	9.50	-	-	3.548	3.423	4.750	-	-	-	-	-	6,590	7,910	144,010	-	-	
		N-80	-	11.00	11.00	3.476	3.351	-	5.000	-	-	3.351	4.405	8,800	9,170	-	246,140	246,000	
		N-80 <sup>x</sup>	-	-	13.40	3.340	-	-	-	-	3.215	4.625	12,110	11,550	-	-	304,000		
		P-105 <sup>x</sup>	-	-	11.00	3.476	-	-	-	-	3.351	4.405	10,700	12,040	-	-	323,000		
		P-105 <sup>x</sup>	-	-	13.40	3.340	-	-	-	-	3.215	4.625	15,900	15,160	-	-	400,000		
		P-105 <sup>x</sup>	-	-	13.40	3.340	-	-	-	-	3.215	4.625	15,900	15,160	-	-	400,000		

\* Collapse resistance, internal yield pressure, body yield strength, and joint yield strength are minimum values with no safety factor.  
<sup>x</sup> Not API standard, it is shown for information only.

## Tubing Performance Properties

Nominal Size (in.)	Outside Diameter (in.)	Grade	Tubing Size				Threaded and Coupled				Integral Joint			Collapse Resistance (Pressure)* (psi)	Internal Joint Pressure* (psi)	Joint Yield Strength*					
			Weight with Couplings		Integral Joint (lb/ft)	Inside Diameter (in.)	Drift Diameter (in.)	Coupling Outside Diameter		Upset Special (in.)	Drift Diameter (in.)	Box Outside Diameter (in.)	Threaded and Coupled			Integral Joint (lb)					
			Non Upset (lb/ft)	Upset (lb/ft)				Non Upset (in.)	Upset Regular (in.)				Non Upset (lb)				Upset (lb)				
4 1/2	4.500	F-25 <sup>x</sup>	12.60	12.75	–	3.958	3.833	5.200	5.563	–	–	–	–	–	2,870	2,630	65,230	90,010	–		
		H-40	12.60	12.75	–	3.958	3.833	5.200	5.563	–	–	–	–	–	4,500	4,220	104,360	144,020	–		
		J-55	12.60	12.75	12.75	3.958	3.833	5.200	5.563	–	3.833	4.910	5.800	143,500	198,030	5,720	5,800	198,030	198,000	–	
		J-55 <sup>x</sup>	–	–	13.50	3.920	–	–	–	–	–	3.795	6,420	–	–	6,200	–	–	–	211,000	–
		C-75	12.60	12.75	12.75	3.958	3.833	5.200	5.563	–	3.833	4.910	7,200	–	–	7,900	195,680	270,030	270,000	–	
		C-75 <sup>x</sup>	–	–	13.50	3.920	–	–	–	–	–	3.795	8,170	–	–	8,460	–	–	–	288,000	–
		C-75 <sup>x</sup>	–	–	15.50	3.826	–	–	–	–	–	3.701	10,390	–	–	9,830	–	–	–	331,000	–
		C-75 <sup>x</sup>	–	–	19.20	3.640	–	–	–	–	–	3.515	12,960	–	–	12,540	–	–	–	412,000	–
		N-80	12.60	12.75	12.75	3.958	3.833	5.200	5.563	–	3.833	4.910	7,500	–	–	8,430	208,730	288,040	288,000	–	
		N-80 <sup>x</sup>	–	–	13.50	3.920	–	–	–	–	–	3.795	8,540	–	–	9,020	–	–	–	307,000	–
		N-80 <sup>x</sup>	–	–	15.50	3.826	–	–	–	–	–	3.701	11,090	–	–	10,480	–	–	–	353,000	–
		N-80 <sup>x</sup>	–	–	19.20	3.640	–	–	–	–	–	3.515	13,820	–	–	13,380	–	–	–	439,000	–
		P-105 <sup>x</sup>	–	–	12.75	3.958	–	–	–	–	–	3.833	8,950	–	–	11,070	–	–	–	378,000	–
		P-105 <sup>x</sup>	–	–	13.50	3.920	–	–	–	–	–	3.795	10,350	–	–	11,840	–	–	–	403,000	–
		P-105 <sup>x</sup>	–	–	15.50	3.826	–	–	–	–	–	3.701	13,820	–	–	13,760	–	–	–	463,000	–
		P-105 <sup>x</sup>	–	–	19.20	3.640	–	–	–	–	–	3.515	18,140	–	–	17,560	–	–	–	567,000	–

\* Collapse resistance, internal yield pressure, body yield strength, and joint yield strength are minimum values with no safety factor.

<sup>x</sup> Not API standard, it is shown for information only.



# A

## Performance Data on Selected Heavy Weight and Non-API Tubing

O.D. (in.) (mm)	Wall Thickness (in.) (mm)	Weight (lb/ft) (kg/m)		Grade	Collapse Pressure (psi) (kPa)	Internal Yield Pressure (psi) (kPa)	Tensile Strength (lb) (daN)
		Plain End	Nominal - Dependent on Type of Joint				
1.050 26.7	.154 3.91		1.5 2.23	J-55	13,770 94,900	14,120 97,400	24,000 10,670
				C-75	18,700 129,400	19,250 132,700	33,000 14,680
				N-80	20,020 138,000	20,530 141,600	35,000 15,570
1.315 33.4	.179 4.55		2.2 3.35	P-105	26,280 181,200	26,950 185,800	46,000 20,460
				J-55	12,940 89,200	13,100 90,300	35,000 15,570
				C-75	17,640 121,600	17,870 123,200	48,000 21,350
1.660 42.2	.191 4.85		3.02 4.49	N-80	18,820 130,000	19,060 131,400	51,000 22,680
				P-105	24,700 170,300	25,010 172,400	67,000 29,800
				J-55	11,200 77,200	11,070 76,300	48,000 21,350
				C-75	15,270 105,300	15,100 104,100	66,000 29,360
				N-80	16,290 112,300	16,100 111,100	71,000 31,580
				P-105	21,380 147,400	21,140 145,800	93,000 41,370

## Performance Data on Selected Heavy Weight and Non-API Tubing

O.D. (in.) (mm)	Wall Thickness (in.) (mm)	Weight (lb/ft) (kg/m)		Grade	Collapse Pressure (psi) (kPa)	Internal Yield Pressure (psi) (kPa)	Tensile Strength (lb) (daN)
		Plain End	Nominal - Dependent on Type of Joint				
1.660 42.2	.198		3.24	J-55	11,560 79,700	11,480 79,200	50,000 22,240
	5.03		4.82	C-75	15,760 108,700	15,660 108,000	68,000 30,250
1.900 48.3	.200		3.64	J-55	10,360 71,400	10,130 69,800	73,000 32,470
	5.08		5.42	C-75	14,130 97,400	13,820 95,290	80,000 35,580
1.900 48.3	.219		4.19	N-80	15,070 103,900	14,740 101,600	84,000 37,360
	5.56		6.23	P-105	19,780 136,400	19,340 133,300	110,000 48,930
1.900 48.3	.219		4.19	J-55	11,220 77,400	11,090 76,500	64,000 28,470
	5.56		6.23	C-75	15,300 105,500	15,130 104,300	87,000 38,700
1.900 48.3	.219		4.19	N-80	16,320 112,500	16,140 111,300	93,000 41,370
	5.56		6.23	P-105	21,420 147,700	21,180 146,000	121,000 53,820

A

# A

## Performance Data on Selected Heavy Weight and Non-API Tubing

O.D. (in.) (mm)	Wall Thickness (in.) (mm)	Weight (lb/ft) (kg/m)		Grade	Collapse Pressure (psi) (kPa)	Internal Yield Pressure (psi) (kPa)	Tensile Strength (lb) (daN)
		Plain End	Nominal - Dependent on Type of Joint				
2.875 73.0	.276 7.01	6.48	7.7 - 7.9 11.46 - 11.75	J-55	9,550 65,800	9,250 63,800	124,000 55,160
				C-75	13,020 89,800	12,600 86,900	169,000 75,170
				N-80	13,890 95,800	13,450 92,700	180,000 80,060
				P-105	18,230 125,700	17,650 121,700	236,000 104,980
				J-55	11,470 79,100	11,390 78,500	149,000 66,280
	.340 8.64		9.5 14.14	C-75	15,640 107,800	15,520 107,000	203,000 90,300
				N-80	16,690 115,100	16,560 114,200	217,000 96,520
2.875 73.0				P-105	21,900 151,000	21,730 149,800	285,000 126,770
				J-55	12,110 83,500	12,120 83,600	157,000 69,830
	.362 9.19		9.7 - 10.4 14.43 - 15.48	C-75	16,510 113,800	16,530 114,000	214,000 69,190
				N-80	17,610 121,400	17,630 121,600	229,000 101,860
				P-105	23,100 159,300	23,140 159,600	300,000 133,440

## Performance Data on Selected Heavy Weight and Non-API Tubing

O.D. (in.) (mm)	Wall Thickness (in.) (mm)	Weight (lb/ft) (kg/m)		Grade	Collapse Pressure (psi) (kPa)	Internal Yield Pressure (psi) (kPa)	Tensile Strength (lb) (daN)
		Plain End	Nominal - Dependent on Type of Joint				
	.392 <b>9.96</b>		10.7 <b>15.92</b>	J-55	12,960 <b>89,400</b>	13,120 <b>90,500</b>	168,000 <b>74,730</b>
				C-75	17,670 <b>121,800</b>	17,890 <b>123,400</b>	229,000 <b>101,860</b>
	N-80		18,850 <b>130,000</b>	19,090 <b>131,600</b>	245,000 <b>108,980</b>		
	P-105		24,740 <b>170,600</b>	25,050 <b>172,700</b>	321,000 <b>142,780</b>		
2.875 <b>73.0</b>	.405 <b>10.28</b>		10.7 - 11.0 <b>15.92 - 16.37</b>	J-55	13,310 <b>91,800</b>	13,570 <b>93,600</b>	173,000 <b>76,950</b>
				C-75	18,150 <b>125,100</b>	18,490 <b>127,500</b>	236,000 <b>104,970</b>
	N-80		19,360 <b>133,500</b>	19,730 <b>136,000</b>	251,000 <b>111,640</b>		
	P-105		25,410 <b>175,200</b>	25,890 <b>178,500</b>	329,000 <b>146,340</b>		
	.440 <b>11.18</b>		11.65 <b>17.34</b>	J-55	14,260 <b>98,300</b>	14,730 <b>101,600</b>	185,000 <b>82,290</b>
				C-75	19,440 <b>134,000</b>	20,090 <b>138,500</b>	252,000 <b>112,090</b>
	N-80		20,740 <b>143,000</b>	21,430 <b>147,800</b>	269,000 <b>119,650</b>		
	P-105		27,220 <b>187,700</b>	28,120 <b>193,900</b>	353,000 <b>157,010</b>		

A

# A

## Performance Data on Selected Heavy Weight and Non-API Tubing

O.D. (in.) (mm)	Wall Thickness (in.) (mm)	Weight (lb/ft) (kg/m)		Grade	Collapse Pressure (psi) (kPa)	Internal Yield Pressure (psi) (kPa)	Tensile Strength (lb) (daN)
		Plain End	Nominal - Dependent on Type of Joint				
	.368 <b>9.35</b>	12.31	12.7 - 12.8 <b>18.90 - 19.05</b>	J-55	10,350 <b>71,400</b>	10,120 <b>69,800</b>	199,000 <b>88,520</b>
				C-75	14,110 <b>97,300</b>	13,800 <b>95,200</b>	272,000 <b>120,900</b>
				N-80	15,060 <b>103,800</b>	14,730 <b>101,600</b>	290,000 <b>128,900</b>
				P-105	19,760 <b>136,200</b>	19,320 <b>133,200</b>	380,000 <b>169,000</b>
				J-55	11,520 <b>79,400</b>	11,440 <b>78,900</b>	222,000 <b>98,750</b>
				C-75	15,710 <b>108,300</b>	15,600 <b>107,600</b>	302,000 <b>134,330</b>
3.500 <b>88.9</b>	.413 <b>10.49</b>	13.6	13.7 <b>20.39</b>	N-80	16,760 <b>115,600</b>	16,640 <b>114,700</b>	322,000 <b>143,230</b>
				P-105	21,990 <b>151,600</b>	21,840 <b>150,600</b>	423,000 <b>188,150</b>
				J-55	12,300 <b>84,800</b>	12,370 <b>85,300</b>	237,000 <b>105,420</b>
	.449 <b>11.40</b>	14.62	14.7 - 15.5 <b>21.87 - 23.06</b>	C-75	16,770 <b>115,600</b>	16,870 <b>116,300</b>	323,000 <b>143,670</b>
				N-80	17,890 <b>123,400</b>	17,990 <b>124,000</b>	345,000 <b>153,460</b>
				P-105	23,480 <b>161,900</b>	23,610 <b>162,800</b>	452,000 <b>201,050</b>

## Performance Data on Selected Heavy Weight and Non-API Tubing

O.D. (in.) (mm)	Wall Thickness (in.) (mm)	Weight (lb/ft) (kg/m)		Grade	Collapse Pressure (psi) (kPa)	Internal Yield Pressure (psi) (kPa)	Tensile Strength (lb) (daN)
		Plain End	Nominal - Dependent on Type of Joint				
	.476 12.9		15.8	J-55	12,930 89,200	13,090 90,300	249,000 110,760
			23.51	C-75	17,630 121,600	17,850 123,100	339,000 150,790
				N-80	18,800 129,600	19,040 131,300	362,000 161,020
				P-105	24,680 170,200	24,990 172,300	475,000 211,280
3.500 88.9	.488 12.39	15.68	15.8	J-55	13,200 91,000	13,420 92,500	254,000 112,280
			23.51	C-75	18,000 124,100	18,300 126,200	346,000 153,900
				N-80	19,200 132,400	19,520 134,600	369,000 164,130
				P-105	25,200 173,800	25,610 176,600	485,000 215,730
	.510 12.95		16.7	J-55	13,690 94,400	14,020 96,700	264,000 117,430
			24.85	C-75	18,670 128,700	19,130 131,900	359,000 159,680
				N-80	19,920 137,300	20,400 140,700	383,000 170,360
				P-105	26,140 180,200	26,770 145,600	503,000 223,730

A



# A

## Performance Data on Selected Heavy Weight and Non-API Tubing

O.D. (in.) (mm)	Wall Thickness (in.) (mm)	Weight (lb/ft) (kg/m)		Grade	Collapse Pressure (psi) (kPa)	Internal Yield Pressure (psi) (kPa)	Tensile Strength (lb) (daN)
		Plain End	Nominal - Dependent on Type of Joint				
3.500 88.9	.530 13.46		17.05 25.37	J-55  C-75  N-80  P-105	14,130 97,400  19,270 132,900  20,560 141,800  26,980 186,000  7,300 50,300  9,790 67,500  10,270 70,800  12,690 87,500  8,330 57,400  11,350 78,300  12,110 83,500  15,900 109,600	14,580 100,500  19,880 137,100  21,200 146,200  27,830 191,900  6,880 47,400  9,390 64,700  10,010 69,000  13,140 90,600  7,940 54,700  10,830 74,700  11,550 79,600  15,160 104,500	272,000 120,990  371,000 165,020  396,000 176,140  519,000 230,850  183,000 81,400  250,000 111,200  267,000 118,760  350,000 155,680  209,000 92,960  285,000 126,770  304,000 135,220  400,000 179,920
	4.000 101.6	.286 7.26		11.0 17.28	J-55  C-75  N-80  P-105		
	.330 8.38	12.93	13.0 - 13.4 - 14.0 19.34 - 19.94 - 20.80	J-55  C-75  N-80  P-105			

## Performance Data on Selected Heavy Weight and Non-API Tubing

O.D. (in.) (mm)	Wall Thickness (in.) (mm)	Weight (lb/ft) (kg/m)		Grade	Collapse Pressure (psi) (kPa)	Internal Yield Pressure (psi) (kPa)	Tensile Strength (lb) (daN)
		Plain End	Nominal - Dependent on Type of Joint				
	.380 9.65	14.66	14.08	J-55	9,460 65,200	9,140 63,000	238,000 105,860
			22.02	C-75	12,900 88,900	12,470 86,000	324,000 144,120
				N-80	13,760 94,900	13,300 91,700	346,000 153,900
				P-105	18,060 124,500	17,460 120,400	454,000 201,940
4.000 101.6	.430 10.92	16.36		J-55	10,550 72,700	10,350 71,400	265,000 117,870
				C-75	14,390 99,200	14,110 97,300	362,000 161,020
				N-80	15,350 105,800	15,050 103,800	386,000 171,690
				P-105	20,150 138,900	19,750 136,200	506,000 225,070
	.500 12.70			J-55	12,030 82,900	12,030 82,900	302,000 134,330
				C-75	16,410 113,100	16,410 113,100	412,000 183,260
				N-80	17,500 120,700	17,500 120,700	440,000 195,710
				P-105	22,970 158,400	22,970 158,400	577,000 256,650

A

# A

## Performance Data on Selected Heavy Weight and Non-API Tubing

O.D. (in.) (mm)	Wall Thickness (in.) (mm)	Weight (lb/ft) (kg/m)		Grade	Collapse Pressure (psi) (kPa)	Internal Yield Pressure (psi) (kPa)	Tensile Strength (lb) (daN)
		Plain End	Nominal - Dependent on Type of Joint				
4.000 <b>101.6</b>	.610		22.5 - 22.8	J-55	14,220 <b>98,000</b>	14,680 <b>101,200</b>	357,000 <b>158,790</b>
	<b>15.49</b>		<b>33.48 - 33.92</b>	C-75	19,390 <b>133,700</b>	20,020 <b>138,000</b>	487,000 <b>216,620</b>
	.205 <b>5.21</b>	9.4	9.5 <b>14.14</b>	N-80	20,680 <b>142,600</b>	21,350 <b>147,200</b>	520,000 <b>231,300</b>
				P-105	27,140 <b>187,100</b>	28,020 <b>193,200</b>	682,000 <b>303,350</b>
	.224 <b>5.69</b>	10.23	10.5 <b>15.62</b>	J-55	3,310 <b>22,800</b>	4,380 <b>30,200</b>	151,000 <b>67,160</b>
				C-75	4,010 <b>27,600</b>	4,790 <b>33,000</b>	165,000 <b>73,390</b>
4.500 <b>114.3</b>	.250 <b>6.35</b>	11.35	11.6 <b>17.26</b>	N-80	4,960 <b>34,200</b>	5,350 <b>36,900</b>	184,000 <b>81,840</b>
				P-105	6,130 <b>42,300</b>	7,290 <b>50,300</b>	250,000 <b>111,200</b>
	2.90 <b>7.37</b>	13.04	13.5 <b>20.09</b>	J-55	6,350 <b>43,800</b>	7,780 <b>53,600</b>	267,000 <b>118,760</b>
				C-75	7,660 <b>52,100</b>	10,690 <b>73,700</b>	350,000 <b>155,680</b>
			N-80	6,420 <b>44,300</b>	6,200 <b>42,700</b>	211,000 <b>93,850</b>	
			P-105	8,170 <b>56,300</b>	8,460 <b>58,300</b>	288,000 <b>128,100</b>	

## Performance Data on Selected Heavy Weight and Non-API Tubing

O.D. (in.) (mm)	Wall Thickness (in.) (mm)	Weight (lb/ft) (kg/m)		Grade	Collapse Pressure (psi) (kPa)	Internal Yield Pressure (psi) (kPa)	Tensile Strength (lb) (daN)
		Plain End	Nominal - Dependent on Type of Joint				
	2.90	13.04	13.5	J-55	8,540 600	9,020 634	307,000 139,300
	7.37	19.41	20.09	C-75	10,350 728	11,840 832	403,000 182,800
	.337	14.98	15.1 - 15.5	J-55	7,620 536	7,210 507	242,000 109,800
	8.56	22.29	22.47 - 23.07	C-75	10,390 730	9,830 691	331,000 150,100
4.500 114.3	.373	16.44	16.9	L/N-80	11,090 780	10,480 737	353,000 160,100
	9.47	24.47	25.15	P-105	13,820 972	13,760 967	463,000 210,000
	.373	16.44	16.9	C-75	11,400 801	10,880 765	363,000 164,700
	9.47	24.47	25.15	L/N-80	12,160 855	11,600 816	387,000 175,500
	.430	18.69	19.2	P-105	15,960 1,122	15,230 1,071	508,000 230,400
	10.92	27.81	28.57	J-55	9,510 669	9,200 647	302,000 137,000
	.430	18.69	19.2	C-75	12,960 876	12,540 882	412,000 186,900
	10.92	27.81	28.57	L/N-90	13,830 972	13,380 941	439,000 199,100

A

# A

## Performance Data on Selected Heavy Weight and Non-API Tubing

O.D. (in.) (mm)	Wall Thickness (in.) (mm)	Weight (lb/ft) (kg/m)		Grade	Collapse Pressure (psi) (kPa)	Internal Yield Pressure (psi) (kPa)	Tensile Strength (lb) (daN)
		Plain End	Nominal - Dependent on Type of Joint				
4.500 114.3	.430 10.92	18.69 27.81	19.2 28.57	P-105	18,150 1,276	17,560 1,235	577,000 261,700
	.500 12.70	21.36 31.79	21.6 32.14	J-55	10,860 764	10,690 752	346,000 156,900
					14,810 1,041	14,580 1,025	471,000 213,600
	.560 14.22	23.56 35.06	24.6 36.61	J-55	15,800 1,111	15,560 1,094	503,000 228,200
					20,740 1,458	20,420 1,436	660,000 299,400
	.630 16.00	26.04 38.75	26.5 39.44	C-75	11,990 843	11,980 842	381,000 172,800
					16,340 1,149	16,330 1,148	520,000 235,900
	.630 16.00	26.04 38.75	26.5 39.44	L/N-80	17,430 1,225	17,420 1,225	555,000 251,700
					22,880 1,609	22,870 1,608	728,000 330,200
	.630 16.00	26.04 38.75	26.5 39.44	P-105	13,240 931	13,480 948	421,000 191,000
					18,060 1,270	18,380 1,292	575,000 260,800
	.630 16.00	26.04 38.75	26.5 39.44	L/N-80	19,260 1,354	19,600 1,378	613,000 278,1000
25,280 1,777					25,730 1,809	804,000 364,700	

**Schlumberger**

**Appendix B  
CASING DATA**

**B**

# B

## API Casing Dimensional Data

Casing Size Outside Diameter (in.)	Weight (lb/ft)	Inside Diameter (in.)	Drift Diameter (in.)	Wall Thickness (in.)	Outside Area $A_o$ (sq. in.)	Inside Area $A_i$ (sq. in.)	Cross-sectional Area $A_s$ (sq. in.)	Moment of Inertia-I (in. <sup>4</sup> )	Ratio of O.D. to I.D.-R
4 1/2	9.50	4.090	3.965	.205	15.904	13.138	2.766	6.393	1.100
	10.50	4.052	3.927	.224	15.904	12.895	3.009	6.896	1.111
	11.60	4.000	3.875	.250	15.904	12.566	3.338	7.563	1.125
	13.50	3.920	3.795	.290	15.904	12.069	3.835	8.538	1.148
	15.10	3.826	3.701	.337	15.904	11.497	4.407	9.610	1.176
	16.60	3.754	3.629	.373	15.904	11.068	4.836	10.380	1.199
4 3/4	18.80	3.640	3.515	.430	15.904	10.406	5.498	11.512	1.236
	16.00	4.082	3.957	.334	17.721	13.087	4.634	11.360	1.164
	18.00	4.000	3.875	.375	17.721	12.566	5.155	12.422	1.188
	20.00	3.910	3.785	.420	17.721	12.007	5.714	13.516	1.215
	21.00	3.850	3.725	.450	17.721	11.642	6.079	14.204	1.234
	11.50	4.560	4.435	4.435	.220	19.635	16.331	3.304	9.456
5	13.00	4.494	4.369	.253	19.635	15.862	3.773	10.658	1.113
	15.00	4.408	4.283	.296	19.635	15.261	4.374	12.147	1.134
	18.00	4.276	4.151	.362	19.635	14.360	5.275	14.269	1.169
	20.30	4.184	4.059	.408	19.635	13.749	5.886	15.637	1.195
	20.80	4.156	4.031	.422	19.635	13.566	6.069	16.035	1.203
	21.00	4.154	4.029	.423	19.635	13.553	6.082	16.063	1.204
23.20	4.044	3.919	.478	19.635	12.844	6.791	17.551	1.236	
24.20	4.000	3.875	.500	19.635	12.566	7.069	18.113	1.250	





# B

## API Casing Dimensional Data

Casing Size		Weight (lb/ft)	Inside Diameter (in.)	Drift Diameter (in.)	Wall Thickness (in.)	Outside Area $A_o$ (sq. in.)	Inside Area $A_i$ (sq. in.)	Cross-sectional Area $A_s$ (sq. in.)	Moment of Inertia-I (in. <sup>4</sup> )	Ratio of O.D. to I.D.-R
Outside Diameter (in.)										
5 1/2		13.00	5.044	4.919	.228	23.758	19.982	3.776	13.144	1.090
		14.00	5.012	4.887	.244	23.758	19.729	4.029	13.943	1.097
		15.00	4.974	4.849	.263	23.758	19.431	4.327	14.872	1.106
		15.50	4.950	4.825	.275	23.758	19.244	4.514	15.447	1.111
		17.00	4.892	4.767	.304	23.758	18.796	4.962	16.804	1.124
		20.00	4.778	4.653	.361	23.758	17.930	5.828	19.335	1.151
5 3/4		23.00	4.670	4.545	.415	23.758	17.129	6.629	21.571	1.178
		25.00	4.580	4.455	.460	23.758	16.475	7.283	23.319	1.201
		26.00	4.548	4.423	.476	23.758	16.245	7.513	23.916	1.209
		14.00	5.290	5.165	.230	25.967	21.979	3.988	15.218	1.087
6		17.00	5.190	5.065	.280	25.967	21.156	4.811	18.043	1.108
		19.50	5.090	4.965	.330	25.967	20.348	5.619	20.710	1.130
		22.50	4.990	4.865	.380	25.967	19.556	6.411	23.224	1.152
		25.20	4.890	4.765	.430	25.967	18.781	7.186	25.591	1.176
6		15.00	5.524	5.399	.238	28.274	23.966	4.308	17.910	1.086
		16.00	5.500	5.375	.250	28.274	23.758	4.516	18.699	1.091
		17.00	5.450	5.325	.275	28.274	23.328	4.946	20.310	1.101
		18.00	5.424	5.299	.288	28.274	23.106	5.168	21.131	1.106
		20.00	5.352	5.227	.324	28.274	22.497	5.777	23.342	1.121
		23.00	5.240	5.115	.380	28.274	21.565	6.709	26.609	1.145
	26.00	5.132	5.007	.434	28.274	20.685	7.589	29.567	1.169	

## API Casing Dimensional Data

Casing Size		Weight (lb/ft)	Inside Diameter (in.)	Drift Diameter (in.)	Wall Thickness (in.)	Outside Area $A_o$ (sq. in.)	Inside Area $A_i$ (sq. in.)	Cross-sectional Area $A_s$ (sq. in.)	Moment of Inertia-I (in. <sup>4</sup> )	Ratio of O.D. to I.D.-R
Outside Diameter (in.)										
6 5/8	13.00	6.255	6.130	.185	34.472	30.729	3.743	19.420	1.059	
	17.00	6.135	6.010	.245	34.472	29.561	4.911	25.022	1.080	
	20.00	6.049	5.924	.288	34.472	28.738	5.734	28.840	1.095	
	22.00	5.989	5.864	.318	34.472	28.171	6.301	31.409	1.106	
	24.00	5.921	5.796	.352	34.472	27.535	6.937	34.229	1.119	
	26.00	5.855	5.730	.385	34.472	26.924	7.548	36.874	1.132	
	28.00	5.791	5.666	.417	34.472	26.339	8.133	39.356	1.144	
	29.00	5.761	5.636	.432	34.472	26.067	8.405	40.491	1.150	
	32.00	5.675	5.550	.475	34.472	25.294	9.178	43.648	1.167	
	17.00	6.538	6.413	.231	38.484	33.572	4.912	28.168	1.071	
	20.00	6.456	6.331	.272	38.484	32.735	5.749	32.583	1.084	
	7	22.00	6.398	6.273	.301	38.484	32.150	6.334	35.607	1.094
23.00		6.366	6.241	.317	38.484	31.829	6.655	37.240	1.100	
24.00		6.336	6.211	.332	38.484	31.530	6.954	38.749	1.105	
26.00		6.276	6.151	.362	38.484	30.935	7.549	41.703	1.115	
28.00		6.214	6.089	.393	38.484	30.327	8.157	44.668	1.126	
29.00		6.184	6.059	.408	38.484	30.035	8.449	46.071	1.132	
30.00		6.154	6.029	.423	38.484	29.744	8.740	47.454	1.137	
32.00		6.094	5.969	.453	38.484	29.167	9.317	50.160	1.149	
33.70		6.048	5.923	.476	38.484	28.729	9.755	52.181	1.157	
34.00		6.040	5.915	.480	38.484	28.653	9.831	52.528	1.159	
35.00		6.004	5.879	.498	38.484	28.312	10.172	54.072	1.166	
35.30		6.000	5.875	.500	38.484	28.274	10.210	54.242	1.167	
38.00	5.920	5.795	.540	38.484	27.525	10.959	57.567	1.182		
40.00	5.836	5.711	.582	38.484	26.750	11.734	60.917	1.199		

B

**API Casing Dimensional Data**

Casing Size Outside Diameter (in.)	Casing Size Weight (lb/ft)	Inside Diameter (in.)	Drift Diameter (in.)	Wall Thickness (in.)	Outside Area $A_o$ (sq. in.)	Inside Area $A_i$ (sq. in.)	Crossectional Area $A_s$ (sq. in.)	Moment of Inertia-I (in. <sup>4</sup> )	Ratio of O.D. to I.D.-R
7 <sup>5</sup> / <sub>8</sub>	20.00	7.125	7.000	.250	45.664	39.871	5.793	39.426	1.070
	24.00	7.025	6.900	.300	45.664	38.760	6.904	46.380	1.085
	26.40	6.969	6.844	.328	45.664	38.144	7.520	50.147	1.094
	29.70	6.875	6.750	.375	45.664	37.122	8.542	56.268	1.109
	33.70	6.765	6.640	.430	45.664	35.944	9.720	63.120	1.127
	36.00	6.705	6.580	.460	45.664	35.309	10.355	66.719	1.137
	38.00	6.655	6.530	.485	45.664	34.784	10.880	69.046	1.146
	39.00	6.625	6.500	.500	45.664	34.472	11.192	71.370	1.151
	45.00	6.445	6.320	.590	45.664	32.624	13.040	81.236	1.183
	45.30	6.435	6.310	.595	45.664	32.523	13.141	81.760	1.185
	45.30	6.560	6.500	.595	47.173	33.798	13.375	86.178	1.181
	8	26.00	7.386	7.261	.307	50.265	42.846	7.419	54.976
8 <sup>1</sup> / <sub>8</sub>	28.00	7.485	7.360	.320	51.849	44.002	7.847	59.849	1.086
	32.00	7.385	7.260	.370	51.849	42.834	9.015	67.919	1.100
	35.50	7.285	7.160	.420	51.849	41.682	10.167	75.669	1.115
	39.50	7.185	7.060	.470	51.849	40.546	11.303	83.105	1.131
	24.00	8.097	7.972	.264	58.426	51.492	6.934	60.656	1.065
	28.00	8.017	7.892	.304	58.426	50.479	7.947	68.871	1.076
8 <sup>5</sup> / <sub>8</sub>	32.00	7.921	7.796	.352	58.426	49.278	9.148	78.411	1.089
	36.00	7.825	7.700	.400	58.426	48.090	10.336	87.610	1.102
	38.00	7.775	7.650	.425	58.426	47.478	10.948	92.269	1.109
	40.00	7.725	7.600	.450	58.426	46.869	11.557	96.839	1.117
	43.00	7.651	7.526	.487	58.426	45.975	12.451	103.441	1.127
	44.00	7.625	7.500	.500	58.426	45.664	12.762	105.716	1.131
	48.00	7.537	7.412	.544	58.426	44.616	13.810	113.245	1.144
	49.00	7.511	7.386	.557	58.426	44.308	14.118	115.419	1.148

## API Casing Dimensional Data

Casing Size Outside Diameter (in.)	Weight (lb/ft)	Inside Diameter (in.)	Drift Diameter (in.)	Wall Thickness (in.)	Outside Area $A_o$ (sq. in.)	Inside Area $A_i$ (sq. in.)	Cross-sectional Area $A_s$ (sq. in.)	Moment of Inertia-I (in. <sup>4</sup> )	Ratio of O.D. to I.D.-R
9	34.00	8.290	8.134	.355	63.617	53.976	9.641	90.222	1.086
	38.00	8.196	8.040	.402	63.617	52.759	10.858	100.560	1.098
	40.00	8.150	7.994	.425	63.617	52.168	11.449	105.491	1.104
	45.00	8.032	7.876	.484	63.617	50.668	12.949	117.764	1.121
	50.20	7.910	7.754	.545	63.617	49.141	14.476	129.897	1.138
	55.00	7.812	7.656	.594	63.617	47.931	15.686	139.244	1.152
	29.30	9.063	8.907	.281	72.760	64.511	8.249	90.107	1.062
	32.30	9.001	8.845	.312	72.760	63.631	9.129	99.076	1.069
	36.00	8.921	8.765	.352	72.760	62.505	10.255	110.379	1.079
	38.00	8.885	8.760	.370	72.760	62.002	10.758	115.368	1.083
9 <sup>5</sup> / <sub>8</sub>	40.00	8.835	8.679	.395	72.760	61.306	11.454	122.196	1.089
	42.00	8.799	8.643	.413	72.760	60.807	11.953	127.041	1.094
	43.50	8.755	8.599	.435	72.760	60.201	12.559	132.882	1.099
	47.00	8.681	8.525	.472	72.760	59.187	13.573	142.510	1.109
	53.50	8.535	8.379	.545	72.760	57.213	15.547	160.796	1.128
	58.40	8.435	8.279	.595	72.760	55.880	16.880	172.791	1.141
	61.10	8.375	8.219	.625	71.760	55.088	17.672	179.786	1.149
	71.80	8.125	7.969	.750	72.760	51.849	20.911	207.356	1.185
	33.00	9.384	9.228	.308	78.540	69.162	9.378	110.227	1.066
	41.50	9.200	9.044	.400	78.540	66.476	12.064	139.215	1.087
10	45.50	9.120	8.964	.440	78.540	65.325	13.215	151.288	1.096
	50.50	9.016	8.860	.492	78.540	63.844	14.696	166.515	1.109
	55.50	8.908	8.752	.546	78.540	62.323	16.217	181.780	1.123
	61.20	8.790	8.634	.605	78.540	60.683	17.857	197.835	1.138

B

**API Casing Dimensional Data**

Outside Diameter (in.)	Casing Size		Inside Diameter (in.)	Drift Diameter (in.)	Wall Thickness (in.)	Outside Area $A_o$ (sq. in.)	Inside Area $A_i$ (sq. in.)	Cross-sectional Area $A_s$ (sq. in.)	Moment of Inertia-I (in. <sup>4</sup> )	Ratio of O.D. to I.D.-R
	Weight (lb/ft)									
10 <sup>3</sup> / <sub>4</sub>	32.75		10.192	10.036	.279	90.762	81.585	9.177	125.874	1.055
	35.75		10.136	9.980	.307	90.762	80.691	10.071	137.420	1.061
	40.00		10.054	9.898	.348	90.762	79.390	11.372	153.984	1.069
	40.50		10.050	9.894	.350	90.762	79.327	11.435	154.782	1.070
	45.00		9.960	9.804	.395	90.762	77.913	12.849	172.480	1.079
	45.50		9.950	9.794	.400	90.762	77.756	13.006	174.417	1.080
	48.00		9.902	9.746	.424	90.762	77.008	13.754	183.634	1.086
	51.00		9.850	9.694	.450	90.762	76.201	14.561	193.469	1.091
	54.00		9.784	9.628	.483	90.762	75.183	15.579	205.730	1.099
	55.50		9.760	9.604	.495	90.762	74.815	15.947	210.127	1.101
	60.70		9.660	9.504	.545	90.762	73.290	17.472	228.103	1.113
	65.70		9.560	9.404	.595	90.762	71.780	18.982	245.530	1.124
71.10		9.450	9.294	.650	90.762	70.138	20.624	264.078	1.138	
81.00		9.250	9.094	.750	90.762	67.201	23.561	296.181	1.162	
38.00		11.150	10.994	.300	108.434	97.643	10.791	176.968	1.054	
42.00		11.084	10.928	.333	108.434	96.490	11.944	194.773	1.060	
47.00		11.000	10.844	.375	108.434	95.033	13.401	216.979	1.068	
50.00		10.950	10.794	.400	108.434	94.171	14.263	229.957	1.073	
54.00		10.880	10.724	.435	108.434	92.971	15.463	247.830	1.080	
60.00		10.772	10.616	.489	108.434	91.134	17.300	274.737	1.091	
61.00		10.770	10.614	.490	108.434	91.101	17.333	275.228	1.091	
65.00		10.682	10.526	.534	108.434	89.618	18.816	296.550	1.100	
40.00		11.384	11.228	.308	113.097	101.784	11.313	193.454	1.054	

## API Casing Dimensional Data

Casing Size Outside Diameter (in.)	Weight (lb/ft)	Inside Diameter (in.)	Drift Diameter (in.)	Wall Thickness (in.)	Outside Area $A_o$ (sq. in.)	Inside Area $A_i$ (sq. in.)	Crosssectional Area $A_s$ (sq. in.)	Moment of Inertia-I (in. <sup>4</sup> )	Ratio of O.D. to I.D.-R
13	40.00	12.438	12.282	.281	132.732	121.504	11.228	227.163	1.045
	45.00	12.360	12.204	.320	132.732	119.985	12.747	256.356	1.052
	50.00	12.282	12.126	.359	132.732	118.475	14.257	285.002	1.058
	54.00	12.220	12.064	.390	132.732	117.282	15.450	307.386	1.064
13 <sup>3/8</sup>	48.00	12.715	12.559	.330	140.500	126.976	13.524	287.861	1.052
	54.50	12.615	12.459	.380	140.500	124.987	15.513	327.750	1.060
	61.00	12.515	12.359	.430	140.500	123.013	17.487	366.702	1.069
	68.00	12.415	12.259	.480	140.500	121.055	19.445	404.731	1.077
	72.00	12.347	12.191	.514	140.500	119.733	20.767	430.071	1.083
	77.00	12.275	12.119	.550	140.500	118.340	22.160	456.449	1.090
	83.00	12.175	12.019	.600	140.500	116.420	24.080	492.323	1.099
	83.50	12.175	12.019	.600	140.500	116.420	24.080	492.323	1.099
14	85.00	12.159	12.003	.608	140.500	116.114	24.386	497.982	1.100
	98.00	11.937	11.781	.719	140.500	111.913	28.587	574.219	1.120
	50.00	13.344	13.156	.328	153.938	139.850	14.088	329.366	1.049
	55.00	15.376	15.188	.312	201.062	185.685	15.377	473.248	1.041
16	65.00	15.250	15.062	.375	201.062	182.654	18.408	562.084	1.049
	70.00	15.198	15.010	.401	201.062	181.410	19.652	598.110	1.053
	75.00	15.124	14.936	.438	201.062	179.648	21.414	648.745	1.058
	84.00	15.010	14.822	.495	201.062	176.950	24.112	725.308	1.066
	109.00	14.688	14.500	.656	201.062	169.440	31.622	935.335	1.089
	118.00	14.570	14.382	.715	201.062	166.728	34.334	1,004.873	1.0988
18	80.00	17.180	16.992	.410	254.469	231.812	22.657	876.752	1.048

B

# B

## API Casing Dimensional Data

Outside Diameter (in.)	Casing Size		Inside Diameter (in.)	Drift Diameter (in.)	Wall Thickness (in.)	Outside Area $A_o$ (sq. in.)	Inside Area $A_i$ (sq. in.)	Cross-sectional Area $A_s$ (sq. in.)	Moment of Inertia-I (in. <sup>4</sup> )	Ratio of O.D. to I.D.-R
	Weight (lb/ft)									
18 <sup>5</sup> / <sub>8</sub>	78.00		17.855	17.667	.385	272.447	250.386	22.061	917.886	1.043
	87.50		17.755	17.567	.435	272.447	247.589	24.858	1,028.716	1.049
	96.50		17.655	17.467	.485	272.447	244.808	27.639	1,137.689	1.055
20	90.00		19.166	18.978	.417	314.159	288.504	25.655	1,230.354	1.044
	94.00		19.124	18.936	.438	314.159	287.241	26.918	1,288.224	1.046
	106.50		19.000	18.812	.500	314.159	283.528	30.631	1,456.864	1.053
21 <sup>1</sup> / <sub>2</sub>	133.00		18.730	18.542	.635	314.159	275.528	38.631	1,812.812	1.068
	92.50		20.710	20.522	.395	363.050	336.860	26.190	1,458.696	1.038
	103.00		20.610	20.422	.445	363.050	333.615	29.435	1,631.846	1.043
24 <sup>1</sup> / <sub>2</sub>	114.00		20.510	20.322	.495	363.050	330.385	32.665	1,802.494	1.048
	88.00		23.850	23.662	.325	471.435	446.752	24.683	1,803.519	1.027
	100.50		23.750	23.562	.375	471.435	443.013	28.422	2,068.224	1.032
	113.00		23.650	23.462	.425	471.435	439.290	32.145	2,329.607	1.036

## API Casing Sizes and Capacities

O.D. in.	Weight lb/ft	I.D. in.	Capacity			
			Gallons per Lineal Foot	Cubic Feet Lineal Foot	Barrels per Lineal Foot	Lineal Feet per Barrel
4½	9.50	4.090	0.6825	0.0912	0.01624	61.539
	10.50	4.052	0.6698	0.0895	0.01594	62.699
	11.60	4.000	0.6528	0.0872	0.01554	64.340
	12.60	3.958	0.6391	0.0854	0.01521	65.712
	13.50	3.920	0.6269	0.0838	0.01492	66.993
	15.10	3.826	0.5972	0.0798	0.01421	70.325
	16.60	3.754	0.5749	0.0768	0.01368	73.048
	17.70	3.697	0.5576	0.0745	0.01327	75.318
18.80	3.640	0.5405	0.0722	0.01287	77.696	
4¾	16.00	4.082	0.6798	0.0908	0.01618	61.781
5	11.50	4.560	0.8483	0.1134	0.02019	49.507
	13.00	4.494	0.8239	0.1101	0.01961	50.972
	15.00	4.408	0.7927	0.1059	0.01887	52.980
	18.00	4.276	0.7459	0.0997	0.01776	56.302
	20.30	4.184	0.7142	0.0954	0.01700	58.805
	21.00	4.154	0.7040	0.0941	0.01676	59.658
	23.20	4.044	0.6672	0.0891	0.01588	62.947
5½	13.00	5.044	1.0380	0.1387	0.02471	40.462
	14.00	5.012	1.0249	0.1370	0.02440	40.980
	15.00	4.974	1.0094	0.1349	0.02403	41.609
	15.50	4.950	0.9997	0.1336	0.02380	42.013
	17.00	4.892	0.9764	0.1305	0.02324	43.015
	20.00	4.778	0.9314	0.1245	0.02217	45.093
	23.00	4.670	0.8898	0.1189	0.02118	47.202
26.00	4.548	0.8439	0.1128	0.02009	49.769	
5¾	14.00	5.290	1.1417	0.1526	0.02718	36.786
	17.00	5.190	1.0989	0.1469	0.02616	38.217
	19.50	5.090	1.0570	0.1413	0.02516	39.734
	22.50	4.990	1.0159	0.1358	0.02418	41.342
	25.20	4.890	0.9756	0.1304	0.02322	43.051
6	15.00	5.524	1.2449	0.1664	0.02964	33.736
	16.00	5.500	1.2342	0.1649	0.02938	34.031
	17.00	5.450	1.2118	0.1619	0.02885	34.658
	18.00	5.424	1.2003	0.1604	0.02857	34.991
	20.00	5.352	1.1686	0.1562	0.02782	35.939
	23.00	5.240	1.1202	0.1497	0.02667	37.492
	26.00	5.140	1.0779	0.1440	0.02566	38.965

B



## API Casing Sizes and Capacities

B

O.D. in.	Weight lb/ft	I.D. in.	Capacity			
			Gallons per Lineal Foot	Cubic Feet Lineal Foot	Barrels per Lineal Foot	Lineal Feet per Barrel
$6\frac{5}{8}$	13.00	6.255	1.5963	0.2133	0.03800	26.311
	17.00	6.135	1.5356	0.2052	0.03656	27.350
	20.00	6.049	1.4928	0.1995	0.03554	28.134
	22.00	5.989	1.4634	0.1956	0.03484	28.700
	24.00	5.921	1.4303	0.1912	0.03405	29.363
	26.00	5.855	1.3986	0.1869	0.03330	30.029
	28.00	5.791	1.3682	0.1829	0.03257	30.696
	29.00	5.761	1.3541	0.1810	0.03223	31.017
	32.00	5.675	1.3139	0.1756	0.03128	31.964
	34.00	5.595	1.2772	0.1707	0.03040	32.885
7	17.00	6.538	1.7440	0.2331	0.04152	24.083
	20.00	6.456	1.7005	0.2273	0.04048	24.698
	22.00	6.398	1.6701	0.2232	0.03976	25.148
	23.00	6.366	1.6534	0.2210	0.03936	25.402
	24.00	6.336	1.6379	0.2189	0.03899	25.643
	26.00	6.276	1.6070	0.2148	0.03826	26.135
	28.00	6.214	1.5754	0.2105	0.03750	26.659
	29.00	6.184	1.5602	0.2085	0.03714	26.919
	30.00	6.154	1.5451	0.2065	0.03678	27.182
	32.00	6.094	1.5151	0.2025	0.03607	27.720
	33.70	6.048	1.4923	0.1944	0.03553	28.143
	34.00	6.040	1.4884	0.1989	0.03543	28.218
	35.00	6.004	1.4707	0.1966	0.03501	28.557
	35.30	6.000	1.4688	0.1963	0.03497	28.595
	38.00	5.920	1.4298	0.1911	0.03404	29.373
40.00	5.836	1.3896	0.1857	0.03308	30.225	
41.00	5.820	1.3819	0.1847	0.03290	30.391	
44.00	5.720	1.3349	0.1784	0.03178	31.463	
$7\frac{5}{8}$	20.00	7.125	2.0712	0.2768	0.04931	20.278
	24.00	7.025	2.0135	0.2691	0.04793	20.859
	26.40	6.969	1.9815	0.2648	0.04717	21.196
	29.70	6.875	1.9284	0.2577	0.04591	21.799
	33.70	6.765	1.8672	0.2496	0.04445	22.493
	36.00	6.705	1.8342	0.2451	0.04367	22.898
	38.00	6.655	1.8069	0.2415	0.04302	23.243
	39.00	6.625	1.7907	0.2393	0.04263	23.454
	45.30	6.435	1.6894	0.2258	0.04022	24.860

## API Casing Sizes and Capacities

O.D. in.	Weight lb/ft	I.D. in.	Capacity			
			Gallons per Lineal Foot	Cubic Feet Lineal Foot	Barrels per Lineal Foot	Lineal Feet per Barrel
7 <sup>3</sup> / <sub>4</sub>	46.10	6.560	1.7558	0.2347	0.04180	23.921
8	26.00	7.386	2.2257	0.2975	0.05299	18.870
8 <sup>1</sup> / <sub>8</sub>	28.00	7.485	2.2858	0.3055	0.05442	18.374
	32.00	7.385	2.2251	0.2974	0.05297	18.875
	35.50	7.285	2.1653	0.2894	0.05155	19.397
	39.50	7.185	2.1062	0.2815	0.05014	19.941
8 <sup>5</sup> / <sub>8</sub>	24.00	8.097	2.6749	0.3575	0.06368	15.701
	28.00	8.017	2.6223	0.3505	0.06243	16.016
	32.00	7.921	2.5598	0.3421	0.06094	16.407
	36.00	7.825	2.4982	0.3339	0.05947	16.812
	38.00	7.775	2.4663	0.3296	0.05872	17.029
	40.00	7.725	2.4347	0.3254	0.05796	17.250
	43.00	7.651	2.3883	0.3192	0.05686	17.585
	44.00	7.625	2.3721	0.3170	0.05647	17.706
	48.00	7.537	2.3176	0.3098	0.05518	18.121
49.00	7.511	2.3017	0.3076	0.05480	18.247	
8 <sup>3</sup> / <sub>4</sub>	49.70	7.636	2.3789	0.3180	0.05664	17.655
9	34.00	8.290	2.8039	0.3748	0.06675	14.979
	38.00	8.196	2.7407	0.3663	0.06525	15.324
	40.00	8.150	2.7100	0.3622	0.06452	15.498
	45.00	8.032	2.6321	0.3518	0.06266	15.957
	50.20	7.910	2.5527	0.3412	0.06077	16.453
55.00	7.812	2.4899	0.3328	0.05928	16.868	
9 <sup>5</sup> / <sub>8</sub>	29.30	9.063	3.3512	0.4479	0.07978	12.533
	32.30	9.001	3.3055	0.4418	0.07870	12.706
	36.00	8.921	3.2470	0.4340	0.07730	12.935
	38.00	8.885	3.2208	0.4305	0.07668	13.040
	40.00	8.835	3.1847	0.4257	0.07582	13.188
	42.00	8.799	3.1588	0.4222	0.07520	13.296
	43.50	8.755	3.1273	0.4180	0.07445	13.430
	47.00	8.681	3.0746	0.4110	0.07320	13.660
	53.50	8.535	2.9721	0.3973	0.07076	14.131
	58.40	8.435	2.9028	0.3880	0.06911	14.468
	61.10	8.375	2.8617	0.3825	0.06813	14.676
	71.80	8.125	2.6934	0.3600	0.06412	15.593

B

## API Casing Sizes and Capacities

B

O.D. in.	Weight lb/ft	I.D. in.	Capacity			
			Gallons per Lineal Foot	Cubic Feet Lineal Foot	Barrels per Lineal Foot	Lineal Feet per Barrel
9 <sup>3</sup> / <sub>4</sub>	59.20	8.560	2.9895	0.3996	0.07117	14.049
9 <sup>7</sup> / <sub>8</sub>	62.80	8.625	3.0351	0.4057	0.07226	13.838
10	33.00	9.384	3.5928	0.4802	0.08554	11.690
	41.50	9.200	3.4533	0.4616	0.08221	12.162
	45.50	9.120	3.3935	0.4536	0.08079	12.376
	50.50	9.016	3.3165	0.4433	0.07896	12.664
	55.50	8.908	3.2375	0.4327	0.07708	12.973
	61.20	8.790	3.1523	0.4213	0.07505	13.323
10 <sup>3</sup> / <sub>4</sub>	32.75	10.192	4.2381	0.5665	0.10090	9.910
	35.75	10.136	4.1917	0.5603	0.09980	10.020
	40.50	10.050	4.1209	0.5508	0.09811	10.192
10 <sup>3</sup> / <sub>4</sub>	45.50	9.950	4.0393	0.5399	0.09617	10.398
	48.00	9.902	4.0004	0.5347	0.09524	10.499
	51.00	9.850	3.9585	0.5291	0.09424	10.610
	54.00	9.784	3.9056	0.5220	0.09298	10.753
	55.50	9.760	3.8865	0.5195	0.09253	10.806
	60.70	9.660	3.8072	0.5089	0.09064	11.031
	65.70	9.560	3.7288	0.4984	0.08877	11.263
	71.10	9.450	3.6435	0.4870	0.08674	11.527
	76.00	9.350	3.5668	0.4768	0.08492	11.775
	81.00	9.250	3.4909	0.4666	0.08311	12.031
11 <sup>3</sup> / <sub>4</sub>	38.00	11.150	5.0723	0.6780	0.12076	8.280
	42.00	11.084	5.0124	0.6700	0.11934	8.379
	47.00	11.000	4.9368	0.6599	0.11753	8.507
	54.00	10.880	4.8296	0.6456	0.11498	8.696
	60.00	10.772	4.7342	0.6328	0.11271	8.871
	65.00	10.682	4.6554	0.6223	0.11084	9.021
	71.00	10.586	4.5721	0.6111	0.10885	9.186
11 <sup>7</sup> / <sub>8</sub>	71.80	10.711	4.6808	0.6257	0.11144	8.973
12	40.00	11.384	5.2874	0.7068	0.12588	7.943
12 <sup>3</sup> / <sub>4</sub>	43.00	12.130	6.0031	0.8024	0.14292	6.996
	53.00	11.970	5.8458	0.7814	0.13918	7.184

# API Casing Performance Properties

Size Outside Diameter (in.)	Grade	Weight Per Foot with Couplings (lb/ft)	Inside Diameter (in.)	Thread & Coupling		Extreme Line		Collapse* Resistance (Pressure) (psi)	Internal Yield (Burst) Pressure*				Joint Yield Strength (1000 lbs)*				
				Drift Diameter (in.)	Coupling Outside Diameter (in.)	Drift Diameter (in.)	Box Outside Diameter (in.)		Plain End or Extreme Line (psi)	Round Thread (psi)	Long (psi)	Buttress Thread (psi)	Thread & Coupling Joint	Buttress Thread	Extreme Line Joint		
4 1/2	F-25*	9.50	4.090	3.965	5.000	-	-	1,920	-	1,990	-	-	69	71	-	-	
	H-40	9.50	4.090	3.965	5.000	-	-	2,770	3,190	3,190	-	-	111	77	-	-	
	J-55	9.50	4.090	3.965	5.000	-	-	3,310	4,380	4,380	-	-	152	101	-	-	
	J-55	10.50	4.052	3.927	5.000	-	-	4,010	4,790	4,790	-	-	165	132	-	203	
	J-55	11.60	4.000	3.875	5.000	-	-	4,960	5,350	5,350	5,350	5,350	184	154	162	225	
	K-55	9.50	4.090	3.965	5.000	-	-	3,310	4,380	4,380	-	-	152	112	-	-	
	K-55	10.50	4.052	3.927	5.000	-	-	4,010	4,790	4,790	-	-	165	146	-	249	
	K-55	11.60	4.000	3.875	5.000	-	-	4,960	5,350	5,350	5,350	5,350	184	170	180	277	
	C-75	11.60	4.000	3.875	5.000	-	-	6,130	7,290	-	7,290	7,290	250	-	212	288	-
	C-75	13.50	3.920	3.795	5.000	-	-	8,170	8,460	-	8,460	8,460	288	-	257	331	-
	N-80	11.60	4.000	3.875	5.000	-	-	6,350	7,780	-	7,780	7,780	267	-	223	304	-
	N-80	13.50	3.920	3.795	5.000	-	-	8,540	9,020	-	9,020	9,020	307	-	270	349	-
	C-95	11.60	4.000	3.875	5.000	-	-	7,010	9,240	-	9,240	9,240	317	-	234	325	-
	C-95	13.50	3.920	3.795	5.000	-	-	9,650	10,710	-	10,710	10,710	364	-	284	374	-
	P-110	11.60	4.000	3.875	5.000	-	-	7,560	10,690	-	10,690	10,690	367	-	279	385	-
	P-110	13.50	3.920	3.795	5.000	-	-	10,670	12,410	-	12,410	12,410	422	-	338	443	-
P-110	15.10	3.826	3.701	5.000	-	-	14,320	14,420	-	14,420	13,460	485	-	406	509	-	
V-150*	15.10	3.826	3.701	5.000	-	-	18,110	-	-	19,660	18,360	661	-	519	683	-	
F-25*	11.50	4.560	4.435	5.563	-	-	1,820	-	1,930	-	-	83	84	-	-	-	
J-55	11.50	4.560	4.435	5.563	-	-	3,060	4,240	4,240	4,240	-	-	182	133	-	-	
J-55	13.00	4.494	4.369	5.563	-	-	4,140	4,870	4,870	4,870	4,870	208	169	182	252	-	
J-55	15.00	4.408	4.283	5.563	4.151	5.360	5,550	5,700	5,700	5,700	5,700	241	207	223	293	328	
K-55	11.50	4.560	4.435	5.563	-	-	3,060	4,240	4,240	4,240	-	-	281	147	-	-	
K-55	13.00	4.494	4.369	5.563	-	-	4,140	4,870	4,870	4,870	4,870	208	186	201	309	-	

\* Collapse resistance, internal yield pressure, body yield strength, and joint yield strength are minimum values with no safety factor.  
 \* Not API standard, it is shown for information only.

A – Hydril TS  
 B – Hydril FJ-P  
 C – Hydril Super FJ-P  
 D – Hydril Super EU



# B

## API Casing Performance Properties

Size Outside Diameter (in.)	Grade	Weight Per Foot with Couplings (lb/ft)	Inside Diameter (in.)	Thread & Coupling			Extreme Line		Collapse* Resistance (Pressure) (psi)	Internal Yield (Burst) Pressure*				Body* Yield Strength (1000 lbs)*					
				Drift Diameter (in.)	Coupling Outside Diameter (in.)	Drift Diameter (in.)	Box Outside Diameter (in.)	Plain End or Extreme Line (psi)		Round Thread Short (psi)	Round Thread Long (psi)	Buttress Thread (psi)	Body* Yield Strength (1000 lbs)	Round Thread Short	Round Thread Long	Buttress Thread	Extreme Line Joint		
5	K-55	15.00	4.408	4.283	5.563	4.151	5.360	5.550	5.700	5.700	5.700	5.700	5.700	241	228	246	359	416	
	C-75	15.00	4.408	4.283	5.563	4.151	5.360	6.970	7.770	7.770	7.770	7.770	7.770	328	295	375	375	416	
	C-75	18.00	4.276	4.151	5.563	4.151	5.360	10,000	9,500	9,500	9,500	9,500	9,500	396	376	452	452	446	
	C-75 <sup>x</sup>	20.30	4.184	-	-	-	4.059	5.094 <sup>c</sup>	11,240	10,710	-	-	-	-	369 <sup>a</sup>	-	-	-	529 <sup>b</sup>
	C-75 <sup>x</sup>	23.20	4.044	-	-	-	3.919	5.094 <sup>c</sup>	12,970	12,550	-	-	-	-	369 <sup>a</sup>	-	-	-	529 <sup>b</sup>
	N-80	15.00	4.408	4.283	5.563	4.151	5.360	7,250	8,290	8,290	8,290	8,290	8,290	350	311	396	396	437	
	N-80	18.00	4.276	4.151	5.563	4.151	5.360	10,490	10,140	10,140	10,140	10,140	10,140	422	396	477	477	469	
	N-80 <sup>x</sup>	20.30	4.184	-	-	-	4.059	5.250 <sup>a</sup>	11,990	11,420	-	-	-	-	388 <sup>a</sup>	284 <sup>b</sup>	363 <sup>c</sup>	363 <sup>c</sup>	556 <sup>b</sup>
	N-80 <sup>x</sup>	23.20	4.044	-	-	-	3.919	5.094 <sup>c</sup>	13,380	13,380	-	-	-	-	388 <sup>a</sup>	294 <sup>b</sup>	363 <sup>c</sup>	363 <sup>c</sup>	556 <sup>b</sup>
	C-95	15.00	4.408	4.283	5.563	4.151	5.360	8,090	9,840	9,840	9,840	9,840	9,840	416	326	424	424	459	
	C-95	18.00	4.276	4.151	5.563	4.151	5.360	12,010	12,040	12,040	12,040	12,040	11,770	501	416	512	512	493	
	C-95 <sup>x</sup>	20.30	4.184	-	-	-	4.059	5.250 <sup>a</sup>	14,250	13,560	-	-	-	-	-	-	-	-	584 <sup>b</sup>
	C-95 <sup>x</sup>	23.20	4.044	-	-	-	3.919	5.094 <sup>c</sup>	16,430	15,890	-	-	-	-	-	-	-	-	584 <sup>b</sup>
	P-110	15.00	4.408	4.283	5.563	4.151	5.360	8,830	11,400	11,400	11,400	11,400	11,400	481	388	503	503	547	
	P-110	18.00	4.276	4.151	5.563	4.151	5.360	13,450	13,940	13,940	13,940	13,940	13,620	580	495	606	606	587	
	P-110 <sup>x</sup>	20.30	4.184	-	-	-	4.059	5.094 <sup>c</sup>	16,490	15,710	-	-	-	-	485 <sup>a</sup>	354 <sup>b</sup>	454 <sup>c</sup>	454 <sup>c</sup>	696 <sup>b</sup>
	P-110 <sup>x</sup>	23.20	4.044	-	-	-	3.919	5.094 <sup>c</sup>	19,020	18,400	-	-	-	-	485 <sup>a</sup>	354 <sup>b</sup>	454 <sup>c</sup>	454 <sup>c</sup>	696 <sup>b</sup>
	V-150 <sup>x</sup>	15.00	4.408	4.283	5.563	-	-	-	10,260	-	-	15,540	15,540	656	497	685	-	-	
	V-150 <sup>x</sup>	18.00	4.276	4.151	5.563	-	-	-	16,860	-	-	19,000	18,580	791	634	826	-	-	
	V-150 <sup>x</sup>	20.80	4.156	4.031	5.563	-	-	-	22,860	-	-	20,280	18,580	910	755	847	-	-	
V-150 <sup>x</sup>	24.20	4.000	3.875	5.563	-	-	-	27,000	-	-	20,280	18,580	1,060	905	847	-	-		
F-25 <sup>x</sup>	13.00	5.044	4.919	6.050	-	-	-	1,660	-	1,810	-	-	94	95	-	-	-		
H-40	14.00	5.012	4.887	6.050	-	-	-	2,630	3,110	3,110	-	-	161	130	-	-	-		
J-55	14.00	5.012	4.887	6.050	-	-	-	3,120	4,270	4,270	-	-	222	172	-	-	-		

\*Collapse resistance, internal yield pressure, body yield strength, and joint yield strength are minimum values with no safety factor.  
<sup>x</sup> Not API standard, it is shown for information only.

A – Hydril TS  
 B – Hydril FJ-P  
 C – Hydril Super FJ-P  
 D – Hydril Super EU

# API Casing Performance Properties

Size Outside Diameter (in.)	Grade	Weight Per Foot with Couplings (lb/ft)	Inside Diameter (in.)	Thread & Coupling		Extreme Line		Collapse* Resistance (Pressure) (psi)	Internal Yield (Burst) Pressure*				Body* Yield Strength (1000 lbs)	Joint Yield Strength (1000 lbs)*				
				Drift Diameter (in.)	Coupling Outside Diameter (in.)	Drift Diameter (in.)	Box Outside Diameter (in.)		Plain End or Extreme Line (psi)	Round Thread (psi)	Long (psi)	Buttress Thread (psi)		Round Thread (psi)	Long (psi)	Buttress Thread (psi)	Extreme Line Joint (psi)	
5 1/2	J-55	15.50	4.950	4.825	6.050	4.653	5.860	4.040	4.810	4.810	4.810	4.810	248	202	217	300	339	
	J-55	17.00	4.892	4.767	6.050	4.653	5.860	4.910	5.320	5.320	5.320	5.320	273	229	247	329	372	
	K-55	14.00	5.012	4.887	6.050	-	-	-	3,120	4,270	-	-	222	189	-	-	-	-
	K-55	15.50	4.950	4.825	6.050	4.653	5.860	4.040	4.810	4.810	4.810	4.810	248	222	239	366	429	
	K-55	17.00	4.892	4.767	6.050	4.653	5.860	4.910	5.320	5.320	5.320	5.320	273	252	272	402	471	
	C-75	17.00	4.892	4.767	6.050	4.653	5.860	6.070	7,250	-	7,250	7,250	372	-	327	423	471	
	C-75	20.00	4.778	4.653	6.050	4.653	5.860	8.440	8,610	-	8,610	8,430	437	-	403	497	497	
	C-75	23.00	4.670	4.545	6.050	4.545	5.860	10.460	9,900	-	9,260	8,430	497	-	473	550	549	
	C-75 <sup>x</sup>	26.00	4.548	-	-	-	4.423	5.656 <sup>c</sup>	11,860	11,360	-	-	-	4323 <sup>a</sup>	-	-	-	678 <sup>b</sup>
	N-80	17.00	4.892	4.767	6.050	4.653	5.860	6.280	7,740	7,740	7,740	7,740	397	-	348	446	496	
	N-80	20.00	4.778	4.653	6.050	4.653	5.860	8.830	9,190	9,190	9,190	8,990	466	-	428	524	523	
	N-80	23.00	4.670	4.545	6.050	4.545	5.860	11,160	10,560	10,560	-	9,880	530	-	502	579	577	
	N-80 <sup>x</sup>	26.00	4.548	-	-	-	4.423	5.656 <sup>c</sup>	12,650	12,120	-	-	-	455 <sup>a</sup>	315 <sup>b</sup>	451 <sup>c</sup>	713 <sup>b</sup>	
	C-95	17.00	4.892	4.767	6.050	4.653	5.860	6.930	9,190	9,190	9,190	9,190	471	-	374	480	521	
	C-95	20.00	4.778	4.653	6.050	4.653	5.860	10,000	10,910	10,910	-	10,910	554	-	460	563	549	
	C-95	23.00	4.670	4.545	6.050	4.545	5.860	12,920	12,540	12,540	-	11,730	630	-	540	608	606	
	C-95 <sup>x</sup>	26.00	4.548	-	-	-	4.423	5.656 <sup>c</sup>	15,020	14,390	-	-	-	-	-	-	-	749 <sup>b</sup>
	P-110	17.00	4.892	4.767	6.050	4.653	5.860	7.460	10,640	10,640	-	10,640	546	-	445	568	820	
P-110	20.00	4.778	4.653	6.050	4.653	5.860	11,080	12,640	12,640	-	12,640	641	-	548	867	854		
P-110	23.00	4.670	4.545	6.050	4.545	5.860	14,520	14,520	14,520	-	13,580	729	-	643	724	722		
P-110 <sup>x</sup>	26.00	4.548	-	-	-	4.423	5.656 <sup>c</sup>	17,390	16,660	-	-	-	569 <sup>a</sup>	393 <sup>b</sup>	564 <sup>c</sup>	892 <sup>b</sup>		
V-150 <sup>x</sup>	20.00	4.778	4.653	6.050	-	-	-	13,480	-	-	17,320	874	-	701	908	-		
V-150 <sup>x</sup>	23.00	4.670	4.545	6.050	-	-	-	18,390	-	-	18,520	994	-	823	910	-		
V-150 <sup>x</sup>	26.00	4.548	4.423	6.050	-	-	-	23,720	-	-	22,720	-	-	-	-	-	722 <sup>c</sup>	

\* Collapse resistance, internal yield pressure, body yield strength, and joint yield strength are minimum values with no safety factor.  
<sup>x</sup> Not API standard, it is shown for information only.

A – Hydril TS  
 B – Hydril FJ-P  
 C – Hydril Super FJ-P  
 D – Hydril Super EU



# B

## API Casing Performance Properties

Size Outside Diameter (in.)	Grade	Weight Per Foot with Couplings (lb/ft)	Inside Diameter (in.)	Thread & Coupling		Extreme Line		Collapse* Resistance (Pressure) (psi)	Internal Yield (Burst) Pressure*			Joint Yield Strength (1000 lbs)*				
				Drift Diameter (in.)	Coupling Outside Diameter (in.)	Drift Diameter (in.)	Box Outside Diameter (in.)		Plain End or Extreme Line (psi)	Short (psi)	Long (psi)	Buttress Thread (psi)	Body* Yield Strength (1000 lbs)	Round Thread	Buttress Thread	Extreme Line Joint
6	F-25	15.00	5.524	5.399	6.625	-	-	1,540	1,740	-	-	107	108	-	-	-
	H-40	18.00	5.424	5.299	6.625	-	-	2,780	3,360	-	-	206	179	-	-	-
	J-55	18.00	5.424	5.299	6.625	-	-	3,620	4,620	-	-	283	239	279	-	-
	N-80	18.00	5.424	5.299	6.625	-	-	4,740	-	6,720	-	412	-	323	-	-
	N-80	20.00	5.352	5.227	6.625	-	-	5,690	-	7,560	-	461	-	366	-	-
	N-80	23.00	5.240	5.115	6.625	-	-	7,180	-	8,870	-	536	-	432	-	-
	P-110	23.00	5.240	5.115	6.625	-	-	10,380	-	12,190	-	737	-	565	-	-
	P-110	26.00	5.132	5.007	6.625	-	-	12,380	-	13,920	-	833	-	646	-	-
	F-25	17.00	6.135	6.010	7.390	-	-	1,370	-	1,620	-	123	121	-	-	-
	H-40	20.00	6.049	5.924	7.390	-	-	2,520	3,040	3,040	-	229	184	-	-	-
6 <sup>5/8</sup>	J-55	20.00	6.049	5.924	7.390	-	-	2,970	4,180	4,180	4,180	315	245	266	374	-
	J-55	24.00	5.921	5.796	7.390	5.730	7.000	4,560	5,110	5,110	5,110	382	314	340	453	477
	K-55	20.00	6.049	5.924	7.390	-	-	2,970	4,180	4,180	4,180	315	267	290	453	-
	K-55	24.00	5.921	5.796	7.390	5.730	7.000	4,560	5,110	5,110	5,110	382	342	372	548	605
	C-75	24.00	5.921	5.796	7.390	5.730	7.000	5,570	6,970	-	6,970	520	-	453	583	605
	C-75	28.00	5.791	5.666	7.390	5.666	7.000	7,830	8,260	-	8,260	610	-	552	683	648
	C-75	32.00	5.675	5.550	7.390	5.550	7.000	9,830	9,410	-	9,410	688	-	638	771	717
	N-80	24.00	5.921	5.796	7.390	5.730	7.000	5,760	7,440	-	7,440	555	-	481	615	637
	N-80	28.00	5.791	5.666	7.390	5.666	7.000	8,170	8,810	-	8,810	651	-	536	721	682
	N-80	32.00	5.675	5.550	7.390	5.550	7.000	10,320	10,040	-	10,040	734	-	677	814	755
6 <sup>5/8</sup>	C-95	24.00	5.921	5.796	7.390	5.730	7.000	6,290	8,830	-	8,830	659	-	546	665	668
	C-95	28.00	5.791	5.666	7.390	5.666	7.000	9,200	10,460	-	10,460	773	-	885	780	716
	C-95	32.00	5.675	5.550	7.390	5.550	7.000	11,800	11,920	-	11,920	872	-	769	880	793
	P-110	24.00	5.921	5.796	7.390	5.730	7.000	6,710	10,230	-	10,230	763	-	641	786	796
	P-110	28.00	5.791	5.666	7.390	5.666	7.000	10,140	12,120	-	12,120	895	-	781	922	852
	P-110	32.00	5.675	5.550	7.390	5.550	7.000	13,200	13,800	-	13,800	1,009	-	904	1,040	944

\*Collapse resistance, internal yield pressure, body yield strength, and joint yield strength are minimum values with no safety factor.  
 x Not API standard, it is shown for information only.

A – Hydril TS  
 B – Hydril FJ-P

C – Hydril Super FJ-P  
 D – Hydril Super EU

# API Casing Performance Properties

Size Outside Diameter (in.)	Grade	Weight Per Foot with Couplings (lb/ft)	Inside Diameter (in.)	Thread & Coupling		Extreme Line		Collapse* Resistance (Pressure) (psi)	Internal Yield (Burst) Pressure*				Joint Yield Strength (1000 lbs)*			
				Drift Diameter (in.)	Coupling Outside Diameter (in.)	Drift Diameter (in.)	Box Outside Diameter (in.)		Plain End or Extreme Line (psi)	Round Thread (psi)	Short (psi)	Long (psi)	Buttress Thread (psi)	Thread & Coupling Joint	Buttress Thread	Extreme Line Joint
	F-25X	17.00	6.538	6.413	7.656	-	-	1,100	-	1,440	-	123	118	-	-	
	H-40	17.00	6.538	6.413	7.656	-	-	1,450	2,310	2,310	-	196	122	-	-	
	H-40	20.00	6.456	6.331	7.656	-	-	1,980	2,720	2,720	-	230	176	-	-	
	J-55	20.00	6.456	6.331	7.656	-	-	2,270	3,740	3,740	-	316	234	-	-	
	J-55	23.00	6.366	6.241	7.656	6.151	7.390	3,270	4,360	4,360	4,360	366	284	313	432	499
	J-55	26.00	6.276	6.151	7.656	6.151	7.390	4,320	4,980	4,980	4,980	415	334	367	490	506
	K-55	20.00	6.456	6.331	7.656	-	-	2,270	3,740	3,740	-	316	254	-	-	-
	K-55	23.00	6.366	6.241	7.656	6.151	7.390	3,270	4,360	4,360	4,360	366	309	341	522	632
	K-55	26.00	6.276	6.151	7.656	6.151	7.390	4,320	4,980	4,980	4,980	415	364	401	592	641
	C-75	23.00	6.366	6.241	7.656	6.151	7.390	3,770	5,940	-	5,940	499	-	416	557	632
	C-75	26.00	6.276	6.151	7.656	6.151	7.390	5,250	6,790	-	6,790	566	-	489	631	641
	C-75	29.00	6.184	6.059	7.656	6.059	7.390	6,760	7,650	-	7,650	634	-	562	707	685
	C-75	32.00	6.094	5.969	7.656	5.969	7.390	8,230	8,490	-	8,490	699	-	633	779	761
	C-75	35.00	6.004	5.879	7.656	5.879	7.530	9,710	9,340	-	8,660	763	-	703	833	850
	C-75	38.00	5.920	5.795	7.656	5.795	7.530	10,680	10,120	-	8,660	822	-	767	833	917
	N-80	23.00	6.366	6.241	7.656	6.151	7.390	3,830	6,340	-	6,340	532	-	442	588	666
	N-80	26.00	6.276	6.151	7.656	6.151	7.390	5,410	7,240	-	7,240	604	-	519	667	675
	N-80	29.00	6.184	6.059	7.656	6.059	7.390	7,020	8,160	-	8,160	676	-	597	746	721
	N-80	32.00	6.094	5.969	7.656	5.969	7.390	8,600	9,060	-	9,060	745	-	672	823	801
	N-80	35.00	6.004	5.879	7.656	5.879	7.530	10,180	9,960	-	9,240	814	-	746	876	895
	N-80	38.00	5.920	5.795	7.656	5.795	7.530	11,390	10,800	-	9,240	877	-	814	876	965
	C-95	23.00	6.366	6.241	7.656	6.151	7.390	4,150	7,530	-	7,530	632	-	505	636	699
	C-95	26.00	6.276	6.151	7.656	6.151	7.390	5,870	8,600	-	8,600	717	-	593	722	709
	C-95	29.00	6.184	6.059	7.656	6.059	7.390	7,820	9,690	-	9,690	803	-	683	808	757
	C-95	32.00	6.094	5.969	7.656	5.969	7.390	9,730	10,760	-	10,760	885	-	768	891	841
	C-95	35.00	6.004	5.879	7.656	5.879	7.530	11,640	11,830	-	10,970	966	-	853	920	940

\*Collapse resistance, internal yield pressure, body yield strength, and joint yield strength are minimum values with no safety factor.  
 x Not API standard, it is shown for information only.

A – Hydril TS  
 B – Hydril FJ-P

C – Hydril Super FJ-P  
 D – Hydril Super EU





# B

## API Casing Performance Properties

Size Outside Diameter (in.)	Grade	Weight Per Foot with Couplings (lb/ft)	Inside Diameter (in.)	Thread & Coupling		Extreme Line		Collapse* Resistance (Pressure) (psi)	Internal Yield (Burst) Pressure*			Joint Yield Strength (1000 lbs)*				
				Drift Diameter (in.)	Coupling Outside Diameter (in.)	Drift Diameter (in.)	Box Outside Diameter (in.)		Plain End or Extreme Line (psi)	Short (psi)	Long (psi)	Buttress Thread (psi)	Body* Yield Strength (1000 lbs)	Round Thread	Thread & Coupling Joint	Extreme Line Joint
7	C-95	38.00	5.920	5.795	7.656	5.795	7.530	13,420	12,820	10,790	10,050	1,041	931	920	1,013	
	P-110	26.00	6.276	6.151	7.656	6.151	7.390	6,210	9,960	9,960	9,960	830	693	853	844	
	P-110	29.00	6.184	6.059	7.656	6.059	7.390	8,510	11,220	11,220	11,220	929	797	955	902	
	P-110	32.00	6.094	5.969	7.656	5.969	7.390	10,760	12,460	12,460	11,640	1,025	897	1,053	1,002	
	P-110	35.00	6.004	5.879	7.656	5.879	7.530	13,010	13,700	12,700	11,640	1,119	996	1,096	1,118	
	P-110	38.00	5.920	5.795	7.656	5.795	7.530	15,110	14,850	12,700	11,640	1,205	1,087	1,096	1,207	
	V-150x	29.00	6.184	6.059	6.656	6.656	-	9,800	-	15,300	15,300	15,300	1,267	1,049	1,296	-
	V-150x	32.00	6.094	5.969	7.656	7.656	-	13,020	-	16,990	15,870	15,870	1,398	1,180	1,363	-
	V-150x	35.00	6.004	5.879	7.656	7.656	-	16,230	-	17,320	15,870	15,26	1,526	1,311	1,363	-
	V-150x	38.00	5.920	5.795	7.656	7.656	-	19,240	-	17,320	15,870	1,644	1,430	1,430	1,363	-
7 <sup>5/8</sup>	F-25x	20.00	7.125	7.000	8.500	7.000	-	1,100	-	1,430	-	145	138	-	-	
	H-40	24.00	7.025	6.900	8.500	6.900	-	2,040	2,750	2,750	-	276	212	-	-	
	J-55	26.40	6.969	6.844	8.500	6.750	8.010	2,890	4,140	4,140	4,140	414	315	346	483	
	K-55	26.40	6.969	6.844	8.500	6.750	8.010	2,890	4,140	4,140	4,140	414	342	377	581	
	C-75	26.40	6.969	6.844	8.500	6.750	8.010	3,280	5,650	-	5,650	564	-	461	624	
	C-75	29.70	6.875	6.750	8.500	6.750	8.010	4,670	6,450	-	6,450	641	-	542	709	
	C-75	33.70	6.765	6.640	8.500	6.640	8.010	6,320	7,400	-	7,400	729	-	635	806	
	C-75	39.00	6.625	6.500	8.500	6.500	8.010	8,430	8,610	-	8,610	839	-	751	929	
	N-80	26.40	6.969	6.844	8.500	6.750	8.010	3,400	6,020	-	6,020	602	-	490	659	
	N-80	29.70	6.875	6.750	8.500	6.750	8.010	4,790	6,890	-	6,890	683	-	575	749	
7 <sup>7/8</sup>	N-80	33.70	6.765	6.640	8.500	6.640	8.010	6,560	7,900	-	7,900	778	-	674	852	
	N-80	39.00	6.625	6.500	8.500	6.500	8.010	8,810	9,180	-	9,180	895	-	798	981	
	C-95	26.40	6.969	6.844	8.500	6.750	8.010	3,710	7,150	-	7,150	714	-	560	716	
	C-95	29.70	6.875	6.750	8.500	6.750	8.010	5,120	8,180	-	8,180	811	-	659	813	
	C-95	33.70	6.765	6.640	8.500	6.640	8.010	7,260	9,380	-	9,380	923	-	772	925	
	C-95	39.00	6.625	6.500	8.500	6.500	8.010	9,980	10,900	-	10,900	1,063	-	914	1,065	

\* Collapse resistance, internal yield pressure, body yield strength, and joint yield strength are minimum values with no safety factor.  
 x Not API standard, it is shown for information only.

A – Hydril TS  
 B – Hydril FJ-P

C – Hydril Super FJ-P  
 D – Hydril Super EU

# API Casing Performance Properties

Size Outside Diameter (in.)	Grade	Weight Per Foot with Couplings (lb/ft)	Inside Diameter (in.)	Thread & Coupling		Extreme Line		Collapse* Resistance (Pressure) (psi)	Internal Yield (Burst) Pressure*				Body* Yield Strength (1000 lbs)	Joint Yield Strength (1000 lbs)*				
				Drift Diameter (in.)	Outside Diameter (in.)	Drift Diameter (in.)	Box Outside Diameter (in.)		Plain End or Extreme Line (psi)	Round Thread (psi)	Long (psi)	Buttress Thread (psi)		Thread & Coupling Joint (psi)	Buttress Thread (psi)	Extreme Line Joint (psi)		
7 5/8	P-110	29.70	6.875	6.750	8.500	6.750	8.010	5,340	9,470	-	9,470	9,470	940	-	769	960	922	
	P-110	33.70	6.765	6.640	8.500	6.640	8.010	7,850	10,860	-	10,860	10,860	1,069	-	901	1,093	1,008	
	P-110	39.00	6.625	6.500	8.500	6.500	8.010	11,060	12,620	-	12,620	12,620	1,231	-	1,066	1,258	1,120	
	V-150x	33.70	6.765	6.640	8.500	-	-	-	8,860	-	-	14,800	14,800	1,458	-	1,207	1,482	-
	V-150x	39.00	6.625	6.500	8.500	-	-	-	13,450	-	-	17,210	17,210	1,679	-	1,428	1,706	-
	V-150x	45.30	6.435	6.310	8.500	-	-	-	19,680	-	-	19,680	18,350	1,971	-	1,721	1,932	-
8 5/8	F-25	24.00	8.097	7.972	9.625	-	-	950	-	1,340	-	-	173	-	161	-	-	
	H-40	28.00	8.017	7.892	9.625	-	-	1,640	2,470	2,470	-	-	318	-	233	-	-	
	H-40	32.00	7.921	7.796	9.625	-	-	2,210	2,860	2,860	-	-	366	-	279	-	-	
	J-55	24.00	8.097	7.972	9.625	-	-	1,370	2,950	2,950	-	-	381	-	244	-	-	
	J-55	32.00	7.921	7.796	9.625	7.700	9.120	2,530	3,930	3,930	3,930	3,930	503	372	417	579	686	
	J-55	36.00	7.825	7.700	9.625	7.700	9.120	3,450	4,460	4,460	4,460	4,460	568	434	486	654	688	
	K-55	24.00	8.097	7.972	9.625	-	-	1,370	2,950	2,950	-	-	381	-	263	-	-	
	K-55	32.00	7.921	7.796	9.625	7.700	9.120	2,530	3,930	3,930	3,930	3,930	503	402	452	690	869	
	K-55	36.00	7.825	7.700	9.625	7.700	9.120	3,450	4,460	4,460	4,460	4,460	568	468	526	780	871	
	C-75	36.00	7.825	7.700	9.625	7.700	9.120	4,020	6,090	6,090	-	6,090	775	-	648	847	871	
	C-75	40.00	7.725	7.600	9.625	7.600	9.120	5,350	6,850	6,850	-	6,850	867	-	742	947	942	
	C-75	44.00	7.625	7.500	9.625	7.500	9.120	6,680	7,610	7,610	-	7,610	957	-	834	1,046	1,007	
C-75	49.00	7.511	7.386	9.625	7.386	9.120	8,200	8,480	8,480	-	8,480	1,059	-	939	1,157	1,007		
N-80	36.00	7.825	7.700	9.625	7.700	9.120	4,100	6,490	6,490	-	6,490	827	-	688	895	917		
N-80	40.00	7.725	7.600	9.625	7.600	9.120	5,520	7,300	7,300	-	7,300	925	-	788	1,001	992		
N-80	44.00	7.625	7.500	9.625	7.500	9.120	6,950	8,120	8,120	-	8,120	1,021	-	887	1,105	1,060		
N-80	49.00	7.511	7.386	9.625	7.386	9.120	8,570	9,040	9,040	-	9,040	1,129	-	997	1,222	1,060		
C-95	36.00	7.825	7.700	9.625	7.700	9.120	4,360	7,710	7,710	-	7,710	982	-	789	976	963		
C-95	40.00	7.725	7.600	9.625	7.600	9.120	6,010	8,670	8,670	-	8,670	1,098	-	904	1,092	1,042		
C-95	44.00	7.625	7.500	9.625	7.500	9.120	7,730	9,640	9,640	-	9,640	1,212	-	1,017	1,206	1,113		

\* Collapse resistance, internal yield pressure, body yield strength, and joint yield strength are minimum values with no safety factor.  
 x Not API standard, it is shown for information only.

A – Hydril TS  
 B – Hydril FJ-P

C – Hydril Super FJ-P  
 D – Hydril Super EU



# B

## API Casing Performance Properties

Size Outside Diameter (in.)	Grade	Weight Per Foot with Couplings (lb/ft)	Thread & Coupling		Extreme Line		Collapse* Resistance (Pressure) (psi)	Internal Yield (Burst) Pressure*		Joint Yield Strength (1000 lbs)*						
			Inside Diameter (in.)	Drift Diameter (in.)	Coupling Outside Diameter (in.)	Drift Diameter (in.)		Box Outside Diameter (in.)	Plain End or Extreme Line (psi)	Round Thread Short (psi)	Round Thread Long (psi)	Buttress Thread (psi)	Body* Yield Strength (1000 lbs)	Thread & Coupling Joint Round Thread Short	Thread & Coupling Joint Round Thread Long	Thread & Coupling Joint Buttress Thread
8 <sup>5</sup> / <sub>8</sub>	C-95	49.00	7.511	7.386	9.625	7.386	9.120	9.690	10.740	10.740	10.740	10.740	1.341	1.144	1.334	1.113
	P-110	40.00	7.725	7.600	9.625	7.600	9.120	6.380	10.040	10.040	10.040	10.040	1.271	1.055	1.288	1.240
	P-110	44.00	7.625	7.500	9.625	7.500	9.120	8.400	11.160	11.160	11.160	11.160	1.404	1.186	1.423	1.326
	P-110	49.00	7.511	7.386	9.625	7.386	9.120	10.720	12.430	12.430	12.430	12.430	1.563	1.335	1.574	1.326
	V-150 <sup>x</sup>	44.00	7.625	7.500	9.625	–	–	9.640	–	15.220	15.220	15.220	1.914	1.591	1.925	–
	V-150 <sup>x</sup>	49.00	7.511	7.386	9.625	–	–	12.950	–	16.950	16.950	16.950	2.118	1.789	2.130	–
	F-25 <sup>x</sup>	29.30	9.063	8.907	10.625	–	–	860	–	1.280	–	–	208	185	–	–
	H-40	32.30	9.001	8.845	10.625	–	–	1.400	2.270	2.270	2.270	2.270	365	254	–	–
	H-40	36.00	8.921	8.765	10.625	–	–	1.740	2.560	2.560	2.560	2.560	410	294	–	–
	J-55	36.00	8.921	8.765	10.625	–	–	2.020	3.520	3.520	3.520	3.520	564	394	453	639
J-55	40.00	8.835	8.679	10.625	8.599	10.100	2.570	3.950	3.950	3.950	3.950	630	452	520	714	
K-55	36.00	8.921	8.765	10.625	–	–	2.020	3.520	3.520	3.520	3.520	564	423	489	755	
K-55	40.00	8.835	8.679	10.625	8.599	10.100	2.570	3.950	3.950	3.950	3.950	630	486	561	843	
C-75	40.00	8.835	8.679	10.625	8.599	10.100	2.980	5.390	–	5.390	5.390	859	–	694	926	
C-75	43.50	7.755	8.599	10.625	8.599	10.100	3.750	5.930	–	5.930	5.930	942	–	776	1,016	
C-75	47.00	8.681	8.525	10.625	8.525	10.100	4.630	6.440	–	6.440	6.440	1,018	–	852	1,098	
C-75	53.50	8.535	8.379	10.625	8.379	10.100	6.380	7.430	–	7.430	7.430	1,166	–	999	1,257	
N-80	40.00	8.835	8.679	10.625	8.599	10.100	3.090	5.750	–	5.750	5.750	916	–	737	979	
N-80	43.50	8.755	8.599	10.625	8.599	10.100	3.810	6.330	–	6.330	6.330	1,005	–	825	1,074	
N-80	47.00	8.681	8.525	10.625	8.525	10.100	4.750	6.870	–	6.870	6.870	1,086	–	905	1,161	
N-80	53.50	8.535	8.379	10.625	8.379	10.100	6.620	7.930	–	7.930	7.930	1,244	–	1,062	1,329	
C-95	40.00	8.835	8.679	10.625	8.599	10.100	3.330	6.820	–	6.820	6.820	1,088	–	847	1,074	
C-95	43.50	8.755	8.599	10.625	8.599	10.100	4.130	7.510	–	7.510	7.510	1,193	–	948	1,178	
C-95	47.00	8.681	8.525	10.625	8.525	10.100	5.080	8.150	–	8.150	8.150	1,289	–	1,040	1,273	
C-95	53.50	8.535	8.379	10.625	8.379	10.100	7.330	9.410	–	9.410	9.410	1,477	–	1,220	1,458	
P-110	43.50	8.755	8.599	10.625	8.599	10.100	4.430	8.700	–	8.700	8.700	1,381	–	1,106	1,388	

\* Collapse resistance, internal yield pressure, body yield strength, and joint yield strength are minimum values with no safety factor.  
<sup>x</sup> Not API standard, it is shown for information only.

A – Hydril TS  
 B – Hydril FJ-P

C – Hydril Super FJ-P  
 D – Hydril Super EU

# API Casing Performance Properties

Size Outside Diameter (in.)	Grade	Weight Per Foot with Couplings (lb/ft)	Inside Diameter (in.)	Thread & Coupling		Extreme Line		Collapse* Resistance (Pressure) (psi)	Internal Yield (Burst) Pressure*				Joint Yield Strength (1000 lbs)*				
				Drift Diameter (in.)	Coupling Outside Diameter (in.)	Drift Diameter (in.)	Box Outside Diameter (in.)		Plain End or Extreme Line (psi)	Round Thread (psi)	Short (psi)	Long (psi)	Buttress Thread (psi)	Body* Yield Strength (1000 lbs)	Round Thread	Thread & Coupling Joint	Extreme Line Joint
9 5/8	P-110	47.00	8.681	8.525	10.625	8.525	10.100	5.310	9.440	9.440	9.440	9.440	9.440	1.493	1.213	1.500	1.358
	P-110	53.50	8.535	8.379	10.625	8.379	10.100	7.930	10.900	10.900	10.900	10.900	10.900	1.710	1.422	1.718	1.544
	V-150 <sup>x</sup>	53.50	8.535	8.379	10.625	-	-	-	8.970	-	-	14.860	14.860	2.332	1.909	2.321	-
	V-150 <sup>x</sup>	58.40	8.435	8.279	10.625	-	-	-	11.570	-	-	16.230	16.230	2.532	2.098	2.519	-
	V-150 <sup>x</sup>	61.10	8.375	8.219	10.625	-	-	-	13.130	-	-	17.050	16.560	2.651	2.211	2.638	-
	V-150 <sup>x</sup>	71.80	8.125	7.969	10.625	-	-	-	19.640	-	-	18.060	16.560	3.136	2.672	2.692	-
10 3/4	F-25 <sup>x</sup>	32.75	10.192	10.036	11.750	-	-	650	-	1.140	-	-	-	229	196	-	-
	H-40	32.75	10.192	10.036	11.750	-	-	880	1.820	1.820	1.820	1.820	-	367	205	-	-
	H-40	40.50	10.050	9.894	11.750	-	-	1.420	2.280	2.280	2.280	2.280	-	457	314	-	-
	J-55	40.50	10.050	9.894	11.750	-	-	1.580	3.130	3.130	3.130	3.130	-	629	420	-	700
	J-55	45.50	9.950	9.794	11.750	9.794	9.794	11.460	3.580	3.580	3.580	3.580	-	715	493	-	796
	J-55	51.00	9.850	9.694	11.750	9.694	9.694	11.460	2.700	4.030	4.030	4.030	-	801	565	-	891
	K-55	40.50	10.050	9.894	11.750	-	-	1.580	3.130	3.130	3.130	3.130	-	629	450	-	819
	K-55	45.50	9.950	9.794	11.750	9.794	9.794	11.460	2.090	3.580	3.580	3.580	-	715	528	-	931
	K-55	51.00	9.850	9.694	11.750	9.694	9.694	11.460	2.700	4.030	4.030	4.030	-	801	606	-	1,043
	C-75	51.00	9.850	9.694	11.750	9.694	9.694	11.460	3.100	5.490	5.490	5.490	-	1,092	756	-	1,160
	C-75	55.50	9.760	9.604	11.750	9.604	9.604	11.460	3.950	6.040	6.040	6.040	-	1,196	843	-	1,271
	N-80	51.00	9.850	9.694	11.750	9.694	9.694	11.460	3.220	5.860	5.860	5.860	-	1,165	804	-	1,228
	N-80	55.50	9.760	9.604	11.750	9.604	9.604	11.460	4.020	6.450	6.450	6.450	-	1,276	895	-	1,345
	C-95	51.00	9.850	9.694	11.750	9.694	9.694	11.460	3.490	6.960	6.960	6.960	-	1,383	927	-	1,354
	C-95	55.50	9.760	9.604	11.750	9.604	9.604	11.460	4.300	7.660	7.660	7.660	-	1,515	1,032	-	1,483
	P-110	51.00	9.850	9.694	11.750	9.694	9.694	11.460	3.670	8.060	8.060	8.060	-	1,602	1,080	-	1,594
	P-110	55.50	9.760	9.604	11.750	9.604	9.604	11.460	4.630	8.860	8.860	8.860	-	1,754	1,203	-	1,745
	P-110	60.70	9.660	9.504	11.750	9.504	9.504	11.460	5.860	9.760	9.760	9.760	-	1,922	1,338	-	1,912
P-110	65.70	9.560	9.404	11.750	-	-	-	7.490	10.650	10.650	10.650	-	2,088	1,472	-	2,077	
P-110 <sup>x</sup>	71.10	9.450	9.294	11.750	-	-	-	9.280	-	11.240	-	-	10,980	1,618	-	2,418	-

\*Collapse resistance, internal yield pressure, body yield strength, and joint yield strength are minimum values with no safety factor.  
<sup>x</sup> Not API standard, it is shown for information only.

A – Hydril TS  
 B – Hydril FJ-P  
 C – Hydril Super FJ-P  
 D – Hydril Super EU



# B

## API Casing Performance Properties

Size Outside Diameter (in.)	Grade	Weight Per Foot with Couplings (lb/ft)	Inside Diameter (in.)	Thread & Coupling			Extreme Line			Collapse* Resistance (Pressure) (psi)	Internal Yield (Burst) Pressure*				Body* Yield Strength (1000 lbs)			Joint Yield Strength (1000 lbs)*		
				Drift Diameter (in.)	Coupling Outside Diameter (in.)	Drift Diameter (in.)	Box Outside Diameter (in.)	Plain End or Extreme Line (psi)	Round Thread Short (psi)		Round Thread Long (psi)	Buttress Thread (psi)	Body* Yield Strength (1000 lbs)	Thread & Coupling Joint Round Thread Short	Thread & Coupling Joint Round Thread Long	Buttress Thread	Extreme Line	Joint		
10 <sup>3</sup> / <sub>4</sub>	V-150 <sup>x</sup>	65.70	9.560	9.404	11.750	-	-	8.330	-	14.530	-	14.530	2.847	1.978	-	2.799	-			
	V-150 <sup>x</sup>	71.10	9.450	9.294	11.750	-	-	10.890	-	15.330	-	14.970	3.094	2.174	-	2.957	-			
11 <sup>3</sup> / <sub>4</sub>	F-25 <sup>x</sup>	38.00	11.150	10.994	12.750	-	-	620	-	1.120	-	-	270	222	-	-	-			
	H-40	42.00	11.084	10.928	12.750	-	-	1.070	1.980	1.980	-	-	478	307	-	-	-			
	J-55	47.00	11.000	10.844	12.750	-	-	1.510	3.070	3.070	-	3.070	737	477	-	807	-			
	J-55	54.00	10.880	10.724	12.750	-	-	2.070	3.560	3.560	-	3.560	850	568	-	931	-			
	J-55	60.00	10.772	10.616	12.750	-	-	2.660	4.010	4.010	-	4.010	952	649	-	1,042	-			
	K-55	47.00	11.00	10.844	12.750	-	-	1.510	3.070	3.070	-	3.070	737	509	-	935	-			
	K-55	54.00	10.880	10.724	12.750	-	-	2.070	3.560	3.560	-	3.560	850	606	-	1,079	-			
	K-55	60.00	10.772	10.616	12.750	-	-	2.660	4.010	4.010	-	4.010	952	693	-	1,208	-			
	C-75	60.00	10.772	10.616	12.750	-	-	3.070	5.460	5.460	-	5.460	1,298	869	-	1,361	-			
	N-80	60.00	10.772	10.616	12.750	-	-	3.180	5.830	5.830	-	5.830	1,384	924	-	1,440	-			
13 <sup>3</sup> / <sub>16</sub>	C-95	60.00	10.772	10.616	12.750	-	-	3.440	6.920	6.920	-	6.920	1,644	1,066	-	1,596	-			
	F-25 <sup>x</sup>	48.00	12.715	12.559	14.375	-	-	560	-	1.080	-	-	338	260	-	-	-			
	H-40	48.00	12.715	12.559	14.375	-	-	770	1.730	1.730	-	-	541	322	-	-	-			
	J-55	54.50	12.615	12.459	14.375	-	-	1.130	2.730	2.730	-	2.730	853	514	-	909	-			
	J-55	61.00	12.515	12.359	14.375	-	-	1.540	3.090	3.090	-	3.090	962	595	-	1,025	-			
	J-55	68.00	12.415	12.259	14.375	-	-	1.950	3.450	3.450	-	3.450	1,069	675	-	1,140	-			
	K-55	54.50	12.615	12.459	14.375	-	-	1.130	2.730	2.730	-	2.730	853	547	-	1,038	-			
	K-55	61.00	12.515	12.359	14.375	-	-	1.540	3.090	3.090	-	3.090	962	633	-	1,169	-			
	K-55	68.00	12.415	12.259	14.375	-	-	1.950	3.450	3.450	-	3.450	1,069	718	-	1,300	-			
	C-75	72.00	12.347	12.191	14.375	-	-	2.590	5.040	5.040	-	5.040	1,558	978	-	1,598	-			
	C-75 <sup>x</sup>	77.00	12.275	12.119	14.375	-	-	2.990	5.400	5.400	-	5.400	1,662	1,054	-	2,054	-			
	C-75 <sup>x</sup>	85.00	12.159	12.003	14.375	-	-	3.810	5.970	5.970	-	5.970	1,829	1,177	-	2,261	-			
	C-75 <sup>x</sup>	98.00	11.937	11.781	14.375	-	-	5.720	6.270	6.270	-	6.270	2,144	1,408	-	2,296	-			
	N-80	72.00	12.347	12.191	14.375	-	-	2.670	5.380	5.380	-	5.380	1,661	1,040	-	1,693	-			

\* Collapse resistance, internal yield pressure, body yield strength, and joint yield strength are minimum values with no safety factor.  
<sup>x</sup> Not API standard, it is shown for information only.

A – Hydril TS  
 B – Hydril FJ-P  
 C – Hydril Super FJ-P  
 D – Hydril Super EU

# API Casing Performance Properties

Size Outside Diameter (in.)	Grade	Weight Per Foot with Couplings (lb/ft)	Inside Diameter (in.)	Thread & Coupling		Extreme Line		Collapse* Resistance (Pressure) (psi)	Internal Yield (Burst) Pressure*				Joint Yield Strength (1000 lbs)*						
				Drift Diameter (in.)	Coupling Outside Diameter (in.)	Drift Diameter (in.)	Box Outside Diameter (in.)		Plain End or Extreme Line (psi)	Round Thread (psi)	Long (psi)	Buttress Thread (psi)	Body* Yield Strength (1000 lbs)	Round Thread	Long	Buttress Thread	Extreme Line Joint		
13 3/8	N-80x	77.00	12.275	12.119	14.375	-	-	3,100	-	5,760	-	5,760	-	5,760	1,773	1,122	-	2,148	-
	N-80x	85.00	12.159	12.003	14.375	-	-	3,870	-	6,360	-	6,360	-	6,360	1,951	1,252	-	2,364	-
	N-80x	98.00	11.937	11.781	14.375	-	-	5,910	-	6,680	-	6,680	-	6,530	2,287	1,498	-	2,400	-
	C-95	72.00	12.347	12.191	14.375	-	-	2,820	-	6,390	-	6,390	-	6,390	1,973	1,204	-	1,893	-
	P-110x	72.00	12.347	12.191	14.375	-	-	2,880	-	7,400	-	7,400	-	7,400	2,596	1,402	-	2,433	-
	V-150x	72.00	12.347	12.191	14.375	-	-	2,880	-	10,090	-	10,090	-	10,090	3,323	1,887	-	2,978	-
	F-25x	55.00	15.376	15.188	17.000	-	-	290	-	850	-	850	-	-	384	258	-	-	-
	H-40	65.00	15.250	15.062	17.000	-	-	670	-	1,640	-	1,640	-	-	736	439	-	-	-
	J-55	75.00	15.124	14.936	17.000	-	-	1,020	-	2,630	-	2,630	-	2,630	1,178	710	-	1,200	-
	K-55	84.00	15.010	14.822	17.000	-	-	1,410	-	2,980	-	2,980	-	2,980	1,326	817	-	1,351	-
16	K-55	75.00	15.124	14.936	17.000	-	-	1,020	-	2,630	-	2,630	-	2,630	1,178	752	-	1,331	-
	K-55	84.00	15.010	14.822	17.000	-	-	1,410	-	2,980	-	2,980	-	2,980	1,326	865	-	1,499	-
	K-55x	109.00	14.688	14.500	17.000	-	-	2,560	-	3,950	-	3,950	-	3,950	1,739	1,181	-	1,962	-
	C-75x	109.00	14.688	14.500	17.000	-	-	2,980	-	5,380	-	5,380	-	-	2,372	1,499	-	-	-
	N-80x	109.00	14.688	14.500	17.000	-	-	3,080	-	5,740	-	5,740	-	-	2,530	1,594	-	-	-
	H-40	87.50	17.755	17.567	19.625	-	-	630	-	1,630	-	1,630	-	-	994	559	-	-	-
	J-55	87.50	17.755	17.567	19.625	-	-	630	-	2,250	-	2,250	-	-	1,367	754	-	1,329	-
	K-55	87.50	17.755	17.567	19.625	-	-	630	-	2,250	-	2,250	-	-	1,367	794	-	1,427	-
	F-25x	94.00	19.124	18.936	21.000	-	-	410	-	960	-	960	-	-	673	359	-	-	-
	H-40	94.00	19.124	18.936	21.000	-	-	520	-	1,530	-	1,530	-	-	1,077	581	-	-	-
20	J-55	94.00	19.124	18.936	21.000	-	-	520	-	2,110	-	2,110	-	2,110	1,480	784	907	1,402	-
	J-55	106.50	19.000	18.812	21.000	-	-	770	-	2,410	-	2,410	-	2,410	1,685	913	1,057	1,596	-
	J-55	133.00	18.730	19.542	21.000	-	-	1,500	-	3,060	-	3,060	-	3,060	2,125	1,192	1,380	2,012	-
	K-55	94.00	19.124	18.936	21.000	-	-	520	-	2,110	-	2,110	-	2,110	1,480	824	955	1,479	-
	K-55	106.50	19.000	18.812	21.000	-	-	770	-	2,410	-	2,410	-	2,410	1,685	960	1,113	1,683	-
	K-55	133.00	18.730	18.542	21.000	-	-	1,500	-	3,060	-	3,060	-	3,060	2,125	1,453	2,123	-	

\* Collapse resistance, internal yield pressure, body yield strength, and joint yield strength are minimum values with no safety factor.  
 x Not API standard, it is shown for information only.

A – Hydril TS  
 B – Hydril FJ-P  
 C – Hydril Super FJ-P  
 D – Hydril Super EU



**B**

**Schlumberger**

**Appendix C  
ANNULAR VOLUMES**





**C**

## Annular Volume Between One String of Tubing and Casing

Tubing O.D. 1.050 in.

No allowance made for upsets and couplings.

Casing			Capacity			
O.D. in.	Weight lb/ft	I.D. in.	Gallons per Lineal Foot	Cubic Feet per Lineal Foot	Barrels per Lineal Foot	Lineal Feet per Barrel
2 <sup>3</sup> / <sub>8</sub>	4.00	2.041	0.1249	0.0167	0.00297	336.069
	4.70	1.995	0.1174	0.0156	0.00279	357.752
	5.95	1.867	0.0972	0.0129	0.00231	431.959
	6.20	1.853	0.0951	0.0127	0.00226	441.610
	7.70	1.703	0.0733	0.0098	0.00174	572.641
2 <sup>7</sup> / <sub>8</sub>	6.50	2.441	0.1981	0.0264	0.00471	211.994
	7.90	2.323	0.1751	0.0234	0.00417	239.749
	8.70	2.259	0.1632	0.0218	0.00388	257.323
	9.50	2.195	0.1515	0.0202	0.00360	277.065
	10.70	2.091	0.1334	0.0178	0.00317	314.835
	11.00	2.065	0.1289	0.0172	0.00307	325.595
3 <sup>1</sup> / <sub>2</sub>	7.70	3.068	0.3390	0.0453	0.00807	123.878
	9.20	2.992	0.3202	0.0428	0.00762	131.146
	10.20	2.922	0.3033	0.0405	0.00722	138.448
	12.95	2.750	0.2635	0.0352	0.00627	159.356
	15.80	2.548	0.2199	0.0293	0.00523	190.998
	16.70	2.480	0.2059	0.0275	0.00490	203.934
	17.05	2.440	0.1979	0.0264	0.00471	212.207
4	9.50	3.548	0.4686	0.0626	0.01115	89.627
	11.00	3.476	0.4479	0.0598	0.01066	93.755
	11.60	3.428	0.4344	0.0580	0.01034	96.673
	12.60	3.364	0.4167	0.0557	0.00992	100.787
	13.40	3.340	0.4101	0.0548	0.00976	102.400
4 <sup>1</sup> / <sub>2</sub>	9.50	4.090	0.6375	0.0852	0.01517	65.881
	10.50	4.052	0.6249	0.0835	0.01487	67.212
	11.60	4.000	0.6078	0.0812	0.01447	69.101
	12.60	3.958	0.5941	0.0794	0.01414	70.687
	13.50	3.920	0.5819	0.0777	0.01385	72.171
	15.10	3.826	0.5522	0.0738	0.01314	76.053
	16.60	3.754	0.5299	0.0708	0.01261	79.248
	17.70	3.697	0.5126	0.0685	0.01220	81.927
	18.80	3.640	0.4956	0.0662	0.01179	84.747
4 <sup>3</sup> / <sub>4</sub>	16.00	4.082	0.6348	0.0848	0.01511	66.158



## Annular Volume Between One String of Tubing and Casing

Tubing O.D. 1.050 in.

No allowance made for upsets and couplings.

C

Casing			Capacity			
O.D. in.	Weight lb/ft	I.D. in.	Gallons per Lineal Foot	Cubic Feet per Lineal Foot	Barrels per Lineal Foot	Lineal Feet per Barrel
5	11.50	4.560	0.8033	0.1073	0.01912	52.279
	13.00	4.494	0.7790	0.1041	0.01854	53.915
	15.00	4.408	0.7477	0.0999	0.01780	56.167
	18.00	4.276	0.7010	0.0937	0.01669	59.915
	20.30	4.184	0.6692	0.0894	0.01593	62.758
	21.00	4.154	0.6590	0.0880	0.01569	63.729
	23.20	4.044	0.6222	0.0831	0.01481	67.498
5 <sup>1/2</sup>	13.00	5.044	0.9930	0.1327	0.02364	42.295
	14.00	5.012	0.9799	0.1309	0.02333	42.861
	15.00	4.974	0.9644	0.1289	0.02296	43.549
	15.50	4.950	0.9547	0.1276	0.02273	43.993
	17.00	4.892	0.9314	0.1245	0.02217	45.093
	20.00	4.778	0.8864	0.1184	0.02110	47.381
	23.00	4.670	0.8448	0.1129	0.02011	49.716
	26.00	4.548	0.7989	0.1067	0.01902	52.571
5 <sup>3/4</sup>	14.00	5.290	1.0967	0.1466	0.02611	38.295
	17.00	5.190	1.0540	0.1408	0.02509	39.848
	19.50	5.090	1.0120	0.1352	0.02409	41.500
	22.50	4.990	0.9709	0.1297	0.02311	43.258
	25.20	4.890	0.9306	0.1244	0.02215	45.131
6	15.00	5.524	1.2000	0.1604	0.02857	35.000
	16.00	5.500	1.1892	0.1589	0.02831	35.318
	17.00	5.450	1.1668	0.1559	0.02778	35.994
	18.00	5.424	1.1553	0.1544	0.02750	36.353
	20.00	5.352	1.1236	0.1502	0.02675	37.377
	23.00	5.240	1.0752	0.1437	0.02560	39.060
	26.00	5.140	1.0329	0.1380	0.02459	40.661
6 <sup>5/8</sup>	13.00	6.255	1.5513	0.2073	0.03693	27.074
	17.00	6.135	1.4906	0.1992	0.03549	28.176
	20.00	6.049	1.4479	0.1935	0.03447	29.008
	22.00	5.989	1.4184	0.1896	0.03377	29.610
	24.00	5.921	1.3853	0.1851	0.03298	30.317
	26.00	5.855	1.3536	0.1809	0.03222	31.027
	28.00	5.791	1.3232	0.1768	0.03150	31.740
	29.00	5.761	1.3091	0.1750	0.03116	32.083
	32.00	5.675	1.2690	0.1696	0.03021	33.097
	34.00	5.595	1.2322	0.1647	0.02933	34.085

## Annular Volume Between One String of Tubing and Casing

Tubing O.D. 1.050 in.

No allowance made for upsets and couplings.

Casing			Capacity			
O.D. in.	Weight lb/ft	I.D. in.	Gallons per Lineal Foot	Cubic Feet per Lineal Foot	Barrels per Lineal Foot	Lineal Feet per Barrel
7	17.00	6.538	1.6990	0.2271	0.04045	24.720
	20.00	6.456	1.6555	0.2213	0.03941	25.369
	22.00	6.398	1.6251	0.2172	0.03869	25.844
	23.00	6.366	1.6084	0.2150	0.03829	26.112
	24.00	6.336	1.5929	0.2129	0.03792	26.367
	26.00	6.276	1.5620	0.2088	0.03719	26.888
	28.00	6.214	1.5304	0.2045	0.03643	27.443
	29.00	6.184	1.5152	0.2025	0.03607	27.718
	30.00	5.154	1.5001	0.2005	0.03571	27.997
	32.00	6.094	1.4702	0.1965	0.03500	28.568
	33.70	6.048	1.4474	0.1934	0.03446	29.018
	34.00	6.040	1.4434	0.1929	0.03436	29.097
	35.00	6.004	1.4257	0.1905	0.03394	29.458
	35.30	6.000	1.4238	0.1903	0.03389	29.499
	38.00	5.920	1.3849	0.1851	0.03297	30.327
	40.00	5.836	1.3446	0.1797	0.03201	31.236
	41.00	5.820	1.3370	0.1787	0.03183	31.414
44.00	5.720	1.2899	0.1724	0.03071	32.560	



## Annular Volume Between One String of Tubing and Casing

Tubing O.D. 1.315 in.

No allowance made for upsets and couplings.

C

Casing			Capacity			
O.D. in.	Weight lb/ft	I.D. in.	Gallons per Lineal Foot	Cubic Feet per Lineal Foot	Barrels per Lineal Foot	Lineal Feet per Barrel
2 <sup>7/8</sup>	6.50	2.441	0.1725	0.0230	0.00410	243.409
	7.90	2.323	0.1496	0.0200	0.00356	280.723
	8.70	2.259	0.1376	0.0184	0.00327	305.123
	9.50	2.195	0.1260	0.0168	0.00300	333.282
	10.70	2.091	0.1078	0.0144	0.00256	389.489
	11.00	2.065	0.1034	0.0138	0.00246	406.091
3 <sup>1/2</sup>	7.70	3.068	0.3134	0.0419	0.00746	133.982
	9.20	2.992	0.2946	0.0393	0.00701	142.525
	10.20	2.922	0.2778	0.0371	0.00661	151.191
	12.95	2.750	0.2379	0.0318	0.00566	176.477
	15.80	2.548	0.1943	0.0259	0.00462	216.129
	16.70	2.480	0.1803	0.0241	0.00429	232.843
4	9.50	3.548	0.4430	0.0592	0.01054	94.800
	11.00	3.476	0.4224	0.0564	0.01005	99.430
	11.60	3.428	0.4088	0.0546	0.00973	102.718
	12.60	3.364	0.3911	0.0522	0.00931	107.375
	13.40	3.340	0.3845	0.0514	0.00915	109.208
4 <sup>1/2</sup>	9.50	4.090	0.6119	0.0818	0.01456	68.634
	10.50	4.052	0.5993	0.0801	0.01426	70.080
	11.60	4.000	0.5822	0.0778	0.01386	72.136
	12.60	3.958	0.5686	0.0760	0.01353	73.866
	13.50	3.920	0.5563	0.0743	0.01324	75.487
	15.10	3.826	0.5266	0.0704	0.01253	79.745
	16.60	3.754	0.5044	0.0674	0.01200	83.266
	17.70	3.697	0.4870	0.0651	0.01159	86.228
18.80	3.640	0.4700	0.0628	0.01119	89.358	
4 <sup>3/4</sup>	16.00	4.082	0.6092	0.0814	0.01450	68.935
5	11.50	4.560	0.7778	0.1039	0.01851	53.998
	13.00	4.494	0.7534	0.1007	0.01793	55.745
	15.00	4.408	0.7222	0.0965	0.01719	58.156
	18.00	4.276	0.6754	0.0902	0.01608	62.183
	20.30	4.184	0.6436	0.0860	0.01532	65.251
	21.00	4.154	0.6334	0.0846	0.01508	66.302
	23.20	4.044	0.5966	0.0797	0.01420	70.390

## Annular Volume Between One String of Tubing and Casing

Tubing O.D. 1.315 in.

No allowance made for upsets and couplings.

Casing			Capacity			
O.D. in.	Weight lb/ft	I.D. in.	Gallons per Lineal Foot	Cubic Feet per Lineal Foot	Barrels per Lineal Foot	Lineal Feet per Barrel
5 <sup>1/2</sup>	13.00	5.044	0.9674	0.1293	0.02303	43.413
	14.00	5.012	0.9543	0.1275	0.02272	44.010
	15.00	4.974	0.9388	0.1255	0.02235	44.736
	15.50	4.950	0.9291	0.1242	0.02212	45.203
	17.00	4.892	0.9058	0.1210	0.02156	46.366
	20.00	4.778	0.8608	0.1150	0.02049	48.788
	23.00	4.670	0.8192	0.1095	0.01950	51.267
	26.00	4.548	0.7733	0.1033	0.01841	54.309
5 <sup>3/4</sup>	14.00	5.290	1.0711	0.1431	0.02550	39.209
	17.00	5.190	1.0284	0.1374	0.02448	40.839
	19.50	5.090	0.9864	0.1318	0.02348	42.576
	22.50	4.990	0.9453	0.1263	0.02250	44.428
	25.20	4.890	0.9050	0.1209	0.02154	46.407
6	15.00	5.524	1.1744	0.1569	0.02796	35.762
	16.00	5.500	1.1636	0.1555	0.02770	36.094
	17.00	5.450	1.1413	0.1525	0.02717	36.800
	18.00	5.424	1.1297	0.1510	0.02689	37.176
	20.00	5.352	1.0981	0.1467	0.02614	38.248
	23.00	5.240	1.0497	0.1403	0.02499	40.011
	26.00	5.140	1.0073	0.1346	0.02398	41.694
6 <sup>5/8</sup>	13.00	6.255	1.5257	0.2039	0.03632	27.528
	17.00	6.135	1.4650	0.1958	0.03488	28.668
	20.00	6.049	1.4223	0.1901	0.03386	29.529
	22.00	5.989	1.3928	0.1861	0.03316	30.154
	24.00	5.921	1.3598	0.1817	0.03237	30.887
	26.00	5.855	1.3281	0.1775	0.03162	31.624
	28.00	5.791	1.2977	0.1734	0.03089	32.365
	29.00	5.761	1.2835	0.1715	0.03056	32.722
	32.00	5.675	1.2434	0.1662	0.02960	33.778
	34.00	5.595	1.2066	0.1613	0.02872	34.808



## Annular Volume Between One String of Tubing and Casing

Tubing O.D. 1.315 in.

No allowance made for upsets and couplings.

C

Casing			Capacity			
O.D. in.	Weight lb/ft	I.D. in.	Gallons per Lineal Foot	Cubic Feet per Lineal Foot	Barrels per Lineal Foot	Lineal Feet per Barrel
7	17.00	6.538	1.6734	0.2237	0.03984	25.098
	20.00	6.456	1.6299	0.2178	0.03880	25.767
	22.00	6.398	1.5995	0.2138	0.03808	26.257
	23.00	6.366	1.5829	0.2115	0.03768	26.534
	24.00	6.336	1.5673	0.2095	0.03731	26.797
	26.00	6.276	1.5364	0.2053	0.03658	27.335
	28.00	6.214	1.5048	0.2011	0.03582	27.909
	29.00	6.184	1.4897	0.1991	0.03546	28.194
	30.00	6.154	1.4746	0.1971	0.03510	28.482
	32.00	6.094	1.4446	0.1931	0.03439	29.074
	33.70	6.048	1.4218	0.1900	0.03385	29.540
	34.00	6.040	1.4178	0.1895	0.03375	29.622
	35.00	6.004	1.4002	0.1871	0.03333	29.996
	35.30	6.000	1.3982	0.1869	0.03329	30.038
	38.00	5.920	1.3593	0.1817	0.03236	30.898
	40.00	5.836	1.3190	0.1763	0.03140	31.842
	41.00	5.820	1.3114	0.1753	0.03122	32.026
44.00	5.720	1.2643	0.1690	0.03010	33.219	

## Annular Volume Between One String of Tubing and Casing

Tubing O.D. 1.660 in.

No allowance made for upsets and couplings.

Casing			Capacity			
O.D. in.	Weight lb/ft	I.D. in.	Gallons per Lineal Foot	Cubic Feet per Lineal Foot	Barrels per Lineal Foot	Lineal Feet per Barrel
2 <sup>7</sup> / <sub>8</sub>	6.50	2.441	0.1306	0.0174	0.00311	321.411
	7.90	2.323	0.1077	0.0144	0.00256	389.832
	8.70	2.259	0.0957	0.0128	0.00228	438.530
	9.50	2.195	0.0841	0.0112	0.00200	499.141
	10.70	2.091	0.0659	0.0088	0.00157	636.762
	11.00	2.065	0.0615	0.0082	0.00146	682.371
3 <sup>1</sup> / <sub>2</sub>	7.70	3.068	0.2716	0.0363	0.00646	154.639
	9.20	2.992	0.2528	0.0337	0.00601	166.133
	10.20	2.922	0.2359	0.0315	0.00561	178.027
	12.95	2.750	0.1961	0.0262	0.00466	214.159
	15.80	2.548	0.1524	0.0203	0.00362	275.494
	16.70	2.480	0.1385	0.0185	0.00329	303.240
4	9.50	3.548	0.4011	0.0536	0.00955	104.695
	11.00	3.476	0.3805	0.0508	0.00906	110.372
	11.60	3.428	0.3670	0.0490	0.00873	114.438
	12.60	3.364	0.3492	0.0466	0.00831	120.249
	13.40	3.340	0.3427	0.0458	0.00815	122.552
4 <sup>1</sup> / <sub>2</sub>	9.50	4.090	0.5700	0.0762	0.01357	73.676
	10.50	4.052	0.5574	0.0745	0.01327	75.344
	11.60	4.000	0.5403	0.0722	0.01286	77.726
	12.60	3.958	0.5267	0.0704	0.01254	79.738
	13.50	3.920	0.5145	0.0687	0.01225	81.631
	15.10	3.826	0.4848	0.0648	0.01154	86.633
	16.60	3.754	0.4625	0.0618	0.01101	90.804
	17.70	3.697	0.4452	0.0595	0.01060	94.338
4 <sup>3</sup> / <sub>4</sub>	18.80	3.640	0.4281	0.0572	0.01019	98.098
	16.00	4.082	0.5674	0.0758	0.01350	74.022
5	11.50	4.560	0.7359	0.0983	0.01752	57.070
	13.00	4.494	0.7115	0.0951	0.01694	59.026
	15.00	4.408	0.6803	0.0909	0.01619	61.736
	18.00	4.276	0.6335	0.0846	0.01508	66.293
	20.30	4.184	0.6018	0.0804	0.01432	69.791
	21.00	4.154	0.5916	0.0790	0.01408	70.995
	23.20	4.044	0.5548	0.0741	0.01320	75.703

C



## Annular Volume Between One String of Tubing and Casing

Tubing O.D. 1.660 in.

No allowance made for upsets and couplings.

C

Casing			Capacity			
O.D. in.	Weight lb/ft	I.D. in.	Gallons per Lineal Foot	Cubic Feet per Lineal Foot	Barrels per Lineal Foot	Lineal Feet per Barrel
5 <sup>1/2</sup>	13.00	5.044	0.9256	0.1237	0.02203	45.377
	14.00	5.012	0.9124	0.1219	0.02172	46.030
	15.00	4.974	0.8969	0.1199	0.02135	46.824
	15.50	4.950	0.8872	0.1186	0.02112	47.337
	17.00	4.892	0.8639	0.1154	0.02057	48.613
	20.00	4.778	0.8190	0.1094	0.01949	51.283
	23.00	4.670	0.7773	0.1039	0.01850	54.029
	26.00	4.548	0.7314	0.0977	0.01741	57.418
5 <sup>3/4</sup>	14.00	5.290	1.0293	0.1375	0.02450	40.804
	17.00	5.190	0.9865	0.1318	0.02348	42.573
	19.50	5.090	0.9446	0.1262	0.02249	44.463
	22.50	4.990	0.9034	0.1207	0.02151	46.487
	25.20	4.890	0.8631	0.1153	0.02055	48.658
6	15.00	5.524	1.1325	0.1513	0.02696	37.085
	16.00	5.500	1.1217	0.1499	0.02670	37.441
	17.00	5.450	1.0994	0.1469	0.02617	38.202
	18.00	5.424	1.0878	0.1454	0.02590	38.607
	20.00	5.352	1.0562	0.1411	0.02514	39.764
	23.00	5.240	1.0078	0.1347	0.02399	41.674
	26.00	5.140	0.9654	0.1290	0.02298	43.502
6 <sup>5/8</sup>	13.00	6.255	1.4838	0.1983	0.03532	28.305
	17.00	6.135	1.4232	0.1902	0.03388	29.511
	20.00	6.049	1.3804	0.1845	0.03286	30.425
	22.00	5.989	1.3509	0.1805	0.03216	31.089
	24.00	5.921	1.3179	0.1761	0.03137	31.868
	26.00	5.855	1.2862	0.1719	0.03062	32.654
	28.00	5.791	1.2558	0.1678	0.02989	33.445
	29.00	5.761	1.2416	0.1659	0.02956	33.825
	32.00	5.675	1.2015	0.1606	0.02860	34.955
	34.00	5.595	1.1647	0.1557	0.02773	36.059

## Annular Volume Between One String of Tubing and Casing

Tubing O.D. 1.660 in.

No allowance made for upsets and couplings.

Casing			Capacity			
O.D. in.	Weight lb/ft	I.D. in.	Gallons per Lineal Foot	Cubic Feet per Lineal Foot	Barrels per Lineal Foot	Lineal Feet per Barrel
7	17.00	6.538	1.6315	0.2181	0.03884	25.742
	20.00	6.456	1.5881	0.2122	0.03781	26.447
	22.00	6.398	1.5576	0.2082	0.03708	26.963
	23.00	6.366	1.5410	0.2059	0.03669	27.255
	24.00	6.336	1.5254	0.2039	0.03631	27.533
	26.00	6.276	1.4948	0.1997	0.03558	28.101
	28.00	6.214	1.4630	0.1955	0.03483	28.708
	29.00	6.184	1.4478	0.1935	0.03447	29.009
	30.00	6.154	1.4327	0.1915	0.03411	29.315
	32.00	6.094	1.4027	0.1875	0.03339	29.941
	33.70	6.048	1.3799	0.1844	0.03285	30.436
	34.00	6.040	1.3760	0.1839	0.03276	30.523
	35.00	6.004	1.3583	0.1815	0.03234	30.921
	35.30	6.000	1.3563	0.1813	0.03229	30.965
	38.00	5.920	1.3174	0.1761	0.03136	31.880
	40.00	5.836	1.2771	0.1707	0.03040	32.886
41.00	5.820	1.2695	0.1697	0.03022	33.083	
44.00	5.720	1.2224	0.1634	0.02910	34.357	



## Annular Volume Between One String of Tubing and Casing

Tubing O.D. 1.900 in.

No allowance made for upsets and couplings.

C

Casing			Capacity			
O.D. in.	Weight lb/ft	I.D. in.	Gallons per Lineal Foot	Cubic Feet per Lineal Foot	Barrels per Lineal Foot	Lineal Feet per Barrel
3 <sup>1/2</sup>	7.70	3.068	0.2367	0.0316	0.00563	177.409
	9.20	2.992	0.2179	0.0291	0.00518	192.704
	10.20	2.922	0.2010	0.0268	0.00478	108.892
	12.95	2.750	0.1612	0.0215	0.00383	260.453
	15.80	2.548	0.1175	0.0157	0.00279	357.159
	16.70	2.480	0.1036	0.0138	0.00246	405.228
	17.05	2.440	0.0956	0.0127	0.00227	439.256
4	9.50	3.548	0.3663	0.0489	0.00872	141.658
	11.00	3.476	0.3456	0.0462	0.00823	121.502
	11.60	3.428	0.3321	0.0444	0.00790	126.448
	12.60	3.364	0.3144	0.0420	0.00748	133.581
	13.40	3.340	0.3078	0.0411	0.00732	136.429
4 <sup>1/2</sup>	9.50	4.090	0.5352	0.0715	0.01274	78.474
	10.50	4.052	0.5226	0.0698	0.01244	80.370
	11.60	4.000	0.5055	0.0675	0.01203	83.086
	12.60	3.958	0.4918	0.0657	0.01171	85.390
	13.50	3.920	0.4796	0.0641	0.01142	87.564
	15.10	3.826	0.4499	0.0601	0.01071	93.345
	16.60	3.754	0.4276	0.0571	0.01018	98.205
	17.70	3.697	0.4103	0.0548	0.00977	102.352
18.80	3.640	0.3932	0.0525	0.00936	106.793	
4 <sup>3/4</sup>	16.00	4.082	0.5325	0.0711	0.01267	78.867
5	11.50	4.560	0.7010	0.0937	0.01669	59.908
	13.00	4.494	0.6767	0.0904	0.01611	62.066
	15.00	4.408	0.6454	0.0862	0.01536	65.070
	18.00	4.276	0.5987	0.0800	0.01425	70.153
	20.30	4.184	0.5669	0.0757	0.01349	74.082
	21.00	4.154	0.5567	0.0744	0.01325	75.440
	23.20	4.044	0.5199	0.0695	0.01237	80.778

## Annular Volume Between One String of Tubing and Casing

Tubing O.D. 1.900 in.

No allowance made for upsets and couplings.

Casing			Capacity			
O.D. in.	Weight lb/ft	I.D. in.	Gallons per Lineal Foot	Cubic Feet per Lineal Foot	Barrels per Lineal Foot	Lineal Feet per Barrel
5 <sup>1/2</sup>	13.00	5.044	0.8907	0.1190	0.02120	47.153
	14.00	5.012	0.8776	0.1173	0.02089	47.858
	15.00	4.974	0.8621	0.1152	0.02052	48.717
	15.50	4.950	0.8524	0.1139	0.02029	49.273
	17.00	4.892	0.8291	0.1108	0.01974	50.657
	20.00	4.778	0.7841	0.1048	0.01866	53.562
	23.00	4.670	0.7425	0.0992	0.01767	56.566
	26.00	4.548	0.6966	0.0931	0.01658	60.291
5 <sup>3/4</sup>	14.00	5.290	0.9944	0.1329	0.02367	42.235
	17.00	5.190	0.9517	0.1272	0.02265	44.132
	19.50	5.090	0.9097	0.1216	0.02166	46.167
	22.50	4.990	0.8686	0.1161	0.02068	48.353
	25.20	4.890	0.8283	0.1107	0.01972	50.706
6	15.00	5.524	1.0977	0.1467	0.02613	38.262
	16.00	5.500	1.0869	0.1452	0.02587	38.642
	17.00	5.450	1.0645	0.1423	0.02534	39.453
	18.00	5.424	1.0530	0.1407	0.02507	39.885
	20.00	5.352	1.0213	0.1365	0.02431	41.121
	23.00	5.240	0.9729	0.1300	0.02316	43.167
	26.00	5.140	0.9306	0.1244	0.02215	45.131
6 <sup>5/8</sup>	13.00	6.255	1.4490	0.1936	0.03449	28.986
	17.00	6.135	1.3883	0.1855	0.03305	30.252
	20.00	6.049	1.3456	0.1798	0.03203	31.213
	22.00	5.989	1.3161	0.1759	0.03133	31.912
	24.00	5.921	1.2830	0.1715	0.03054	32.734
	26.00	5.855	1.2513	0.1672	0.02979	33.563
	28.00	5.791	1.2209	0.1632	0.02906	34.399
	29.00	5.761	1.2068	0.1613	0.02873	34.802
	32.00	5.675	1.1667	0.1559	0.02777	35.999
	34.00	5.595	1.1299	0.1510	0.02690	37.171



## Annular Volume Between One String of Tubing and Casing

Tubing O.D. 1.900 in.

No allowance made for upsets and couplings.

C

Casing			Capacity			
O.D. in.	Weight lb/ft	I.D. in.	Gallons per Lineal Foot	Cubic Feet per Lineal Foot	Barrels per Lineal Foot	Lineal Feet per Barrel
7	17.00	6.538	1.5967	0.2134	0.03801	26.304
	20.00	6.456	1.5532	0.2076	0.03696	27.040
	22.00	6.398	1.5228	0.2035	0.03625	27.580
	23.00	6.366	1.5061	0.2013	0.03586	27.886
	24.00	6.336	1.4906	0.1992	0.03548	28.176
	26.00	6.276	1.4597	0.1951	0.03475	28.772
	28.00	6.214	1.4281	0.1909	0.03400	29.409
	29.00	6.184	1.4129	0.1888	0.03364	29.725
	30.00	6.154	1.3978	0.1868	0.03328	30.046
	32.00	6.094	1.3678	0.1828	0.03256	30.705
	33.70	6.048	1.3451	0.1798	0.03202	31.225
	34.00	6.040	1.3411	0.1792	0.03193	31.317
	35.00	6.004	1.3234	0.1769	0.03151	31.735
	35.30	6.000	1.3215	0.1766	0.03146	31.782
	38.00	5.920	1.2826	0.1714	0.03053	32.746
	40.00	5.836	1.2423	0.1660	0.02957	33.808
41.00	5.820	1.2347	0.1650	0.02939	34.017	
44.00	5.720	1.1876	0.1587	0.02827	35.365	
7 <sup>5</sup> / <sub>8</sub>	20.00	7.125	1.9239	0.2571	0.04580	21.830
	24.00	7.025	1.8662	0.2494	0.04443	22.506
	26.40	6.969	1.8342	0.2451	0.04367	22.898
	29.70	6.875	1.7811	0.2380	0.04240	23.580
	33.70	6.765	1.7199	0.2299	0.04094	24.420
	36.00	6.705	1.6869	0.2255	0.04016	24.897
	38.00	6.655	1.6597	0.2218	0.03951	25.306
	39.00	6.625	1.6434	0.2196	0.03912	25.556
45.30	6.435	1.5422	0.2061	0.03671	27.234	
7 <sup>3</sup> / <sub>4</sub>	46.10	6.560	1.5030	0.2009	0.03578	27.943

## Annular Volume Between One String of Tubing and Casing

Tubing O.D. 2.063 in.

No allowance made for upsets and couplings.

Casing			Capacity			
O.D. in.	Weight lb/ft	I.D. in.	Gallons per Lineal Foot	Cubic Feet per Lineal Foot	Barrels per Lineal Foot	Lineal Feet per Barrel
4 <sup>1/2</sup>	9.50	4.090	0.5088	0.0680	0.01211	82.539
	10.50	4.052	0.4962	0.0663	0.01181	84.639
	11.60	4.000	0.4791	0.0640	0.01140	87.656
	12.60	3.958	0.4655	0.0622	0.01108	90.224
	13.50	3.920	0.4533	0.0605	0.01079	92.655
	15.10	3.826	0.4235	0.0566	0.01008	99.153
	16.60	3.754	0.4013	0.0536	0.00955	104.654
	17.70	3.697	0.3840	0.0513	0.00914	109.377
	18.80	3.640	0.3669	0.0490	0.00873	114.463
4 <sup>3/4</sup>	16.00	4.082	0.5061	0.0676	0.01205	82.974
5	11.50	4.560	0.6747	0.0901	0.01606	62.248
	13.00	4.494	0.6503	0.0869	0.01548	64.582
	15.00	4.408	0.6191	0.0827	0.01474	67.840
	18.00	4.276	0.5723	0.0765	0.01362	73.384
	20.30	4.184	0.5405	0.0722	0.01287	77.694
	21.00	4.154	0.5303	0.0709	0.01262	79.189
	23.20	4.044	0.4935	0.0659	0.01175	85.092
5 <sup>1/2</sup>	13.00	5.044	0.8643	0.1155	0.02058	48.590
	14.00	5.012	0.8512	0.1137	0.02026	49.340
	15.00	4.974	0.8357	0.1117	0.01989	50.254
	15.50	4.950	0.8260	0.1104	0.01966	50.845
	17.00	4.892	0.8027	0.1073	0.01911	52.320
	20.00	4.778	0.7577	0.1012	0.01804	55.425
	23.00	4.670	0.7161	0.0957	0.01705	58.647
	26.00	4.548	0.6702	0.0896	0.01595	62.662
5 <sup>3/4</sup>	14.00	5.290	0.9681	0.1294	0.02304	43.384
	17.00	5.190	0.9253	0.1236	0.02203	45.389
	19.50	5.090	0.8834	0.1180	0.02103	47.544
	22.50	4.990	0.8422	0.1125	0.02005	49.866
	25.20	4.890	0.8019	0.1072	0.01909	52.372



## Annular Volume Between One String of Tubing and Casing

Tubing O.D. 2.063 in.

No allowance made for upsets and couplings.

C

Casing			Capacity			
O.D. in.	Weight lb/ft	I.D. in.	Gallons per Lineal Foot	Cubic Feet per Lineal Foot	Barrels per Lineal Foot	Lineal Feet per Barrel
6	15.00	5.524	1.0713	0.1432	0.02550	39.203
	16.00	5.500	1.0605	0.1417	0.02525	39.603
	17.00	5.450	1.0382	0.1387	0.02471	40.455
	18.00	5.424	1.0266	0.1372	0.02444	40.909
	20.00	5.352	0.9950	0.1330	0.02369	42.211
	23.00	5.240	0.9466	0.1265	0.02253	44.369
	26.00	5.140	0.9042	0.1208	0.02152	46.447
6 <sup>5</sup> / <sub>8</sub>	13.00	6.255	1.4226	0.1901	0.03387	29.523
	17.00	6.135	1.3619	0.1820	0.03242	30.838
	20.00	6.049	1.3192	0.1763	0.03140	31.837
	22.00	5.989	1.2897	0.1724	0.03070	32.564
	24.00	5.921	1.2567	0.1679	0.02992	33.420
	26.00	5.855	1.2250	0.1637	0.02916	34.286
	28.00	5.791	1.1946	0.1596	0.02844	35.158
	29.00	5.761	1.1804	0.1578	0.02810	35.580
	32.00	5.675	1.1403	0.1524	0.02715	36.832
	34.00	5.595	1.1035	0.1475	0.02627	38.059
7	17.00	6.538	1.5703	0.2099	0.03738	26.746
	20.00	6.456	1.5268	0.2041	0.03635	27.507
	22.00	6.398	1.4964	0.2000	0.03562	28.066
	23.00	6.366	1.4798	0.1978	0.03523	28.382
	24.00	6.336	1.4642	0.1957	0.03486	28.684
	26.00	6.276	1.4333	0.1916	0.03412	29.301
	28.00	6.214	1.4017	0.1873	0.03337	29.962
	29.00	6.184	1.3866	0.1853	0.03301	30.290
	30.00	6.154	1.3715	0.1833	0.03265	30.623
	32.00	6.094	1.3415	0.1793	0.03194	31.308
	33.70	6.048	1.3187	0.1762	0.03139	31.849
	34.00	6.040	1.3148	0.1757	0.03130	31.944
	35.00	6.004	1.2971	0.1733	0.03088	32.380
	35.30	6.000	1.2951	0.1731	0.03083	32.429
	38.00	5.920	1.2562	0.1679	0.02990	33.433
	40.00	5.836	1.2159	0.1625	0.02895	34.541
41.00	5.820	1.2083	0.1615	0.02876	34.759	
44.00	5.720	1.1612	0.1552	0.02764	36.168	

## Annular Volume Between One String of Tubing and Casing

Tubing O.D. 2.063 in.

No allowance made for upsets and couplings.

Casing			Capacity			
O.D. in.	Weight lb/ft	I.D. in.	Gallons per Lineal Foot	Cubic Feet per Lineal Foot	Barrels per Lineal Foot	Lineal Feet per Barrel
7 <sup>5</sup> / <sub>8</sub>	20.00	7.125	1.8975	0.2536	0.04517	22.133
	24.00	7.025	1.8398	0.2459	0.04380	22.828
	26.40	6.969	1.8078	0.2416	0.04304	23.232
	29.70	6.875	1.7547	0.2345	0.04177	23.935
	33.70	6.765	1.6935	0.2263	0.04032	24.800
	36.00	6.705	1.6606	0.2219	0.03953	25.292
	38.00	6.655	1.6333	0.2183	0.03888	25.714
	39.00	6.625	1.6170	0.2161	0.03850	25.973
	45.30	6.435	1.5158	0.2026	0.03609	27.707
7 <sup>3</sup> / <sub>4</sub>	46.10	6.560	1.4767	0.1974	0.03515	28.442





## Annular Volume Between One String of Tubing and Casing

Tubing O.D. 2.375 in.

No allowance made for upsets and couplings.

C

Casing			Capacity			
O.D. in.	Weight lb/ft	I.D. in.	Gallons per Lineal Foot	Cubic Feet per Lineal Foot	Barrels per Lineal Foot	Lineal Feet per Barrel
4 <sup>1/2</sup>	9.50	4.090	0.4523	0.0604	0.01077	92.847
	10.50	4.052	0.4397	0.0587	0.01046	95.512
	11.60	4.000	0.4226	0.0565	0.01006	99.372
	12.60	3.958	0.4090	0.0546	0.00973	102.686
	13.50	3.920	0.3968	0.0530	0.00944	105.846
	15.10	3.826	0.3671	0.0490	0.00874	114.412
	16.60	3.754	0.3448	0.0460	0.00821	121.800
	17.70	3.697	0.3275	0.0437	0.00779	128.244
18.80	3.640	0.3104	0.0414	0.00739	135.293	
4 <sup>3/4</sup>	16.00	4.082	0.4497	0.0601	0.01070	93.398
5	11.50	4.560	0.6182	0.0826	0.01471	67.936
	13.00	4.494	0.5938	0.0793	0.01413	70.725
	15.00	4.408	0.5626	0.0752	0.01339	74.652
	18.00	4.276	0.5158	0.0689	0.01228	81.420
	20.30	4.184	0.4841	0.0647	0.01152	86.761
	21.00	4.154	0.4738	0.0633	0.01128	88.629
23.20	4.044	0.4371	0.0584	0.01040	96.089	
5 <sup>1/2</sup>	13.00	5.044	0.8078	0.1079	0.01923	51.988
	14.00	5.012	0.7947	0.1062	0.01892	52.847
	15.00	4.974	0.7792	0.1041	0.01855	53.897
	15.50	4.950	0.7695	0.1028	0.01832	54.577
	17.00	4.892	0.7462	0.0997	0.01776	56.281
	20.00	4.778	0.7012	0.0937	0.01669	59.890
	23.00	4.670	0.6596	0.0881	0.01570	63.670
26.00	4.548	0.6137	0.0820	0.01461	68.430	
5 <sup>3/4</sup>	14.00	5.290	0.9116	0.1218	0.02170	46.073
	17.00	5.190	0.8688	0.1161	0.02068	48.340
	19.50	5.090	0.8269	0.1105	0.01968	50.792
	22.50	4.990	0.7857	0.1050	0.01870	53.451
	25.20	4.890	0.7454	0.0996	0.01774	56.341
6	15.00	5.524	1.0148	0.1356	0.02416	41.386
	16.00	5.500	1.0040	0.1342	0.02390	41.831
	17.00	5.450	0.9817	0.1312	0.02337	42.783
	18.00	5.424	0.9701	0.1296	0.02309	43.291
	20.00	5.352	0.9385	0.1254	0.02234	44.751
	23.00	5.240	0.8901	0.1189	0.02119	47.185
26.00	5.140	0.8477	0.1133	0.02018	49.542	

## Annular Volume Between One String of Tubing and Casing

Tubing O.D. 2.375 in.

No allowance made for upsets and couplings.

Casing			Capacity			
O.D. in.	Weight lb/ft	I.D. in.	Gallons per Lineal Foot	Cubic Feet per Lineal Foot	Barrels per Lineal Foot	Lineal Feet per Barrel
6 <sup>5</sup> / <sub>8</sub>	13.00	6.255	1.3661	0.1826	0.03252	30.743
	17.00	6.135	1.3055	0.1745	0.03108	32.172
	20.00	6.049	1.2627	0.1688	0.03006	33.261
	22.00	5.989	1.2332	0.1648	0.02936	34.056
	24.00	5.921	1.2002	0.1604	0.02857	34.994
	26.00	5.855	1.1685	0.1562	0.02782	35.943
	28.00	5.791	1.1381	0.1521	0.02709	36.904
	29.00	5.761	1.1239	0.1502	0.02676	37.368
	32.00	5.675	1.0838	0.1448	0.02580	38.751
	34.00	5.595	1.0470	0.1399	0.02492	40.113
7	17.00	6.538	1.5138	0.2023	0.03604	27.744
	20.00	6.456	1.4704	0.1965	0.03500	28.564
	22.00	6.398	1.4399	0.1924	0.03428	29.167
	23.00	6.366	1.4233	0.1902	0.03388	29.509
	24.00	6.336	1.4077	0.1881	0.03351	29.835
	26.00	6.276	1.3769	0.1840	0.03278	30.504
	28.00	6.214	1.3453	0.1798	0.03203	31.220
	29.00	6.184	1.3301	0.1778	0.03166	31.576
	30.00	6.154	1.3150	0.1757	0.03130	31.939
	32.00	6.094	1.2850	0.1717	0.03059	32.684
	33.70	6.048	1.2622	0.1687	0.03005	33.274
	34.00	6.040	1.2583	0.1682	0.02995	33.379
	35.00	6.004	1.2406	0.1658	0.02953	33.854
	35.30	6.000	1.2386	0.1655	0.02949	33.908
	38.00	5.920	1.1997	0.1603	0.02856	35.008
40.00	5.836	1.1594	0.1549	0.02760	36.224	
41.00	5.820	1.1518	0.1539	0.02742	36.463	
44.00	5.720	1.1047	0.1476	0.02630	38.017	
7 <sup>5</sup> / <sub>8</sub>	20.00	7.125	1.8411	0.2461	0.04383	22.813
	24.00	7.025	1.7833	0.2383	0.04245	23.551
	26.40	6.969	1.7513	0.2341	0.04169	23.981
	29.70	6.875	1.6983	0.2270	0.04043	24.731
	33.70	6.765	1.6370	0.2188	0.03897	25.656
	36.00	6.705	1.6041	0.2144	0.03819	26.183
	38.00	6.655	1.5768	0.2107	0.03754	26.636
	39.00	6.625	1.5606	0.2086	0.03715	26.913
	45.30	6.435	1.4593	0.1950	0.03474	28.780



## Annular Volume Between One String of Tubing and Casing

Tubing O.D. 2.375 in.

No allowance made for upsets and couplings.

C

Casing			Capacity			
O.D. in.	Weight lb/ft	I.D. in.	Gallons per Lineal Foot	Cubic Feet per Lineal Foot	Barrels per Lineal Foot	Lineal Feet per Barrel
7 <sup>3</sup> / <sub>4</sub>	46.10	6.560	1.4202	0.1898	0.03381	29.574
8	26.00	7.386	1.9956	0.2667	0.04751	21.046
8 <sup>1</sup> / <sub>8</sub>	28.00	7.485	2.0556	0.2747	0.04894	20.431
	32.00	7.385	1.9950	0.2666	0.04749	21.053
	35.50	7.285	1.9351	0.2586	0.04607	21.704
	39.50	7.185	1.8761	0.2507	0.04466	22.387
8 <sup>5</sup> / <sub>8</sub>	24.00	8.097	2.4447	0.3268	0.05820	17.180
	28.00	8.017	2.3921	0.3197	0.05695	17.557
	32.00	7.921	2.3297	0.3114	0.05546	18.028
	36.00	7.825	2.2680	0.3031	0.05400	18.518
	38.00	7.775	2.2362	0.2989	0.05324	18.782
	40.00	7.725	2.2046	0.2947	0.05248	19.051
	43.00	7.651	2.1582	0.2885	0.05138	19.461
	44.00	7.625	2.1420	0.2863	0.05099	19.608
	48.00	7.537	2.0875	0.2790	0.04970	20.119
49.00	7.511	2.0715	0.2769	0.04932	20.274	
8 <sup>3</sup> / <sub>4</sub>	49.70	7.636	2.1488	0.2872	0.05116	19.545
9 <sup>5</sup> / <sub>8</sub>	29.30	9.063	3.1210	0.4172	0.07430	13.457
	32.30	9.001	3.0753	0.4111	0.07322	13.657
	36.00	8.921	3.0168	0.4032	0.07182	13.921
	38.00	8.885	2.9907	0.3997	0.07120	14.043
	40.00	8.835	2.9545	0.3949	0.07034	14.215
	42.00	8.799	2.9286	0.3914	0.06972	14.341
	43.50	8.755	2.8971	0.3872	0.06897	14.497
	47.00	8.681	2.8445	0.3802	0.06772	14.765
	53.50	8.535	2.7419	0.3665	0.06528	15.317
	58.40	8.435	2.6727	0.3572	0.06363	15.714
	61.10	8.375	2.6316	0.3517	0.06265	15.960
	71.80	8.125	2.4633	0.3292	0.05864	17.050
9 <sup>3</sup> / <sub>4</sub>	59.20	8.560	2.7594	0.3688	0.06569	15.221
9 <sup>7</sup> / <sub>8</sub>	62.80	8.625	2.8050	0.3749	0.06678	14.973

## Annular Volume Between One String of Tubing and Casing

Tubing O.D. 2.375 in.

No allowance made for upsets and couplings.

Casing			Capacity			
O.D. in.	Weight lb/ft	I.D. in.	Gallons per Lineal Foot	Cubic Feet per Lineal Foot	Barrels per Lineal Foot	Lineal Feet per Barrel
10	33.00	9.384	3.3626	0.4495	0.08006	12.490
	41.50	9.200	3.2231	0.4308	0.07673	13.031
	45.50	9.120	3.1633	0.4228	0.07531	13.277
	50.50	9.016	3.0864	0.4125	0.07348	13.608
	55.50	8.908	3.0074	0.4020	0.07160	13.965
	61.20	8.790	2.9222	0.3906	0.06957	14.372
10 <sup>3/4</sup>	32.75	11.192	4.0080	0.5357	0.09542	10.479
	35.75	10.136	3.9615	0.5295	0.09432	10.602
	40.50	10.050	3.8907	0.5201	0.09263	10.795
	45.50	9.950	3.8091	0.5091	0.09069	11.026
	48.00	9.902	3.7702	0.5039	0.08976	11.140
	51.00	9.850	3.7283	0.4983	0.08876	11.265
	54.00	9.784	3.6755	0.4913	0.08750	11.427
	55.50	9.760	3.6563	0.4887	0.08705	11.487
	60.70	9.660	3.5771	0.4781	0.08516	11.741
	65.70	9.560	3.4987	0.4676	0.08330	12.004
	71.10	9.450	3.4134	0.4562	0.08126	12.304
	76.00	9.350	3.3367	0.4460	0.07944	12.587
81.00	9.250	3.2608	0.4358	0.07763	12.880	
11 <sup>3/4</sup>	38.00	11.150	4.8422	0.6472	0.11528	8.673
	42.00	11.084	4.7823	0.6392	0.11386	8.782
	47.00	11.000	4.7066	0.6291	0.11206	8.923
	54.00	10.880	4.5995	0.6148	0.10950	9.131
	60.00	10.772	4.5041	0.6020	0.10723	9.325
	65.00	10.682	4.4253	0.5915	0.10536	9.491
	71.00	10.586	4.3420	0.5804	0.10337	9.673

C

## Annular Volume Between One String of Tubing and Casing

Tubing O.D. 2.875 in.

No allowance made for upsets and couplings.

C

Casing			Capacity			
O.D. in.	Weight lb/ft	I.D. in.	Gallons per Lineal Foot	Cubic Feet per Lineal Foot	Barrels per Lineal Foot	Lineal Feet per Barrel
4 <sup>1/2</sup>	9.50	4.090	0.3452	0.0461	0.00822	121.647
	10.50	4.052	0.3326	0.0444	0.00791	126.264
	11.60	4.000	0.3155	0.0421	0.00751	133.099
	12.60	3.958	0.3019	0.0403	0.00718	139.111
	13.50	3.920	0.2897	0.0387	0.00689	144.976
	15.10	3.826	0.2600	0.0347	0.00619	161.540
	16.60	3.754	0.2377	0.0317	0.00566	176.670
	17.70	3.697	0.2204	0.0294	0.00524	190.560
18.80	3.640	0.2033	0.0271	0.00484	206.550	
4 <sup>3/4</sup>	16.00	4.082	0.3426	0.0457	0.00815	122.594
5	11.50	4.560	0.5111	0.0683	0.01216	82.171
	13.00	4.494	0.4867	0.0650	0.01158	86.287
	15.00	4.408	0.4555	0.0608	0.01084	92.203
	18.00	4.276	0.4087	0.0546	0.00973	102.753
	20.30	4.184	0.3770	0.0503	0.00897	111.408
	21.00	4.154	0.3667	0.0490	0.00873	114.508
	23.20	4.044	0.3300	0.0441	0.00785	127.275
5 <sup>1/2</sup>	13.00	5.044	0.7007	0.0936	0.01668	59.933
	14.00	5.012	0.6876	0.0919	0.01637	61.078
	15.00	4.974	0.6721	0.0898	0.01600	62.484
	15.50	4.950	0.6624	0.0885	0.01577	63.401
	17.00	4.892	0.6391	0.0854	0.01521	65.711
	20.00	4.778	0.5941	0.0794	0.01414	70.685
	23.00	4.670	0.5525	0.0738	0.01315	76.011
	26.00	4.548	0.5066	0.0677	0.01206	82.894
5 <sup>3/4</sup>	14.00	5.290	0.8045	0.1075	0.01915	52.206
	17.00	5.190	0.7617	0.1018	0.01813	55.137
	19.50	5.090	0.7198	0.0962	0.01713	58.350
	22.50	4.990	0.6786	0.0907	0.01615	61.886
	25.20	4.890	0.6383	0.0853	0.01519	65.793
6	15.00	5.524	0.9077	0.1213	0.02161	46.269
	16.00	5.500	0.8969	0.1199	0.02135	46.826
	17.00	5.450	0.8746	0.1169	0.02082	48.022
	18.00	5.424	0.8630	0.1153	0.02054	48.663
	20.00	5.352	0.8314	0.1111	0.01979	50.516
	23.00	5.240	0.7830	0.1046	0.01864	53.639
	26.00	5.140	0.7406	0.0990	0.01763	56.706

## Annular Volume Between One String of Tubing and Casing

Tubing O.D. 2.875 in.

No allowance made for upsets and couplings.

Casing			Capacity			
O.D. in.	Weight lb/ft	I.D. in.	Gallons per Lineal Foot	Cubic Feet per Lineal Foot	Barrels per Lineal Foot	Lineal Feet per Barrel
$6\frac{5}{8}$	13.00	6.255	1.2590	0.1683	0.02997	33.359
	17.00	6.135	1.1984	0.1601	0.02853	35.047
	20.00	6.049	1.1556	0.1544	0.02751	36.344
	22.00	5.989	1.1261	0.1505	0.02681	37.925
	24.00	5.921	1.0931	0.1461	0.02602	38.422
	26.00	5.855	1.0614	0.1418	0.02527	39.570
	28.00	5.791	1.0310	0.1378	0.02454	40.737
	29.00	5.761	0.0168	0.1359	0.02421	41.304
	32.00	5.675	0.9767	0.1305	0.02325	43.000
	34.00	5.595	0.9399	0.1256	0.02237	44.683
7	17.00	6.538	1.4067	0.1880	0.03349	29.856
	20.00	6.456	1.3633	0.1822	0.03245	30.808
	22.00	6.398	1.3328	0.1781	0.03173	31.511
	23.00	6.366	1.3162	0.1759	0.03133	31.910
	24.00	6.336	1.3006	0.1738	0.03096	32.291
	26.00	6.276	1.2698	0.1697	0.03023	33.077
	28.00	6.214	1.2382	0.1655	0.02948	33.921
	29.00	6.184	1.2230	0.1634	0.02911	34.341
	30.00	6.154	1.2079	0.1614	0.02875	34.771
	32.00	6.094	1.1779	0.1574	0.02804	35.656
	33.70	6.048	1.1551	0.1544	0.02750	36.359
	34.00	6.040	1.1512	0.1538	0.02740	36.484
	35.00	6.004	1.1335	0.1515	0.02698	37.053
	35.30	6.000	1.1315	0.1512	0.02694	37.117
	38.00	5.920	1.0926	0.1460	0.02601	38.439
40.00	5.836	1.0523	0.1406	0.02505	39.911	
41.00	5.820	1.0447	0.1396	0.02487	40.201	
44.00	5.720	0.9976	0.1333	0.02375	42.099	
$7\frac{5}{8}$	20.00	7.125	1.7340	0.2317	0.04128	24.222
	24.00	7.025	1.6762	0.2240	0.03990	25.056
	26.40	6.969	1.6443	0.2198	0.03914	25.543
	29.70	6.875	1.5912	0.2127	0.03788	26.395
	33.70	6.765	1.5299	0.2045	0.03642	27.452
	36.00	6.705	1.4970	0.2001	0.03564	28.056
	38.00	6.655	1.4697	0.1964	0.03499	28.577
	39.00	6.625	1.4534	0.1942	0.03460	28.896
	45.30	6.435	1.3522	0.1807	0.03219	31.060



## Annular Volume Between One String of Tubing and Casing

Tubing O.D. 2.875 in.

No allowance made for upsets and couplings.

C

Casing			Capacity			
O.D. in.	Weight lb/ft	I.D. in.	Gallons per Lineal Foot	Cubic Feet per Lineal Foot	Barrels per Lineal Foot	Lineal Feet per Barrel
7 <sup>3</sup> / <sub>4</sub>	46.10	6.560	1.3131	0.1755	0.03126	31.986
8	26.00	7.386	1.8885	0.2524	0.04496	22.240
8 <sup>1</sup> / <sub>8</sub>	28.00 32.00 35.50 39.50	7.485 7.385 7.285 7.185	1.9485 1.8879 1.8280 1.7690	0.2604 0.2523 0.2443 0.2364	0.04639 0.04494 0.04352 0.04211	21.554 22.247 22.975 23.742
8 <sup>5</sup> / <sub>8</sub>	24.00 28.00 32.00 36.00 38.00 40.00 43.00 44.00 48.00 49.00	8.097 8.017 7.921 7.825 7.775 7.725 7.651 7.625 7.537 7.511	2.3376 2.2850 2.2226 2.1609 2.1291 2.0975 2.0511 2.0349 1.9804 1.9644	0.3124 0.3054 0.2971 0.2888 0.2846 0.2803 0.2741 0.2720 0.2647 0.2626	0.05565 0.05440 0.05291 0.05145 0.05069 0.04993 0.04883 0.04844 0.04715 0.04677	17.967 18.380 18.896 19.436 19.726 20.024 20.477 20.640 21.207 21.380
9 <sup>3</sup> / <sub>4</sub>	49.70	7.636	2.0417	0.2729	0.04861	20.571
9	34.00 38.00 40.00 45.00 50.20 55.00	8.290 8.196 8.150 8.032 7.910 7.812	2.4667 2.4034 2.3728 2.2948 2.2155 2.1526	0.3297 0.3212 0.3171 0.3067 0.2961 0.2877	0.05872 0.05722 0.05649 0.05463 0.05274 0.05125	17.027 17.475 17.701 18.302 18.957 19.511
9 <sup>5</sup> / <sub>8</sub>	29.30 32.30 36.00 38.00 40.00 42.00 43.50 47.00 53.50 58.40 61.10 71.80	9.063 9.001 8.921 8.885 8.835 8.799 8.755 8.681 8.535 8.435 8.375 8.125	3.0139 2.9682 2.9097 2.8836 2.8474 2.8215 2.7900 2.7374 2.6348 2.5656 2.5245 2.3562	0.4028 0.3967 0.3889 0.3854 0.3806 0.3771 0.3729 0.3659 0.3522 0.3429 0.3374 0.3149	0.07175 0.07067 0.06927 0.06865 0.06779 0.06717 0.06642 0.06517 0.06273 0.06108 0.06010 0.05609	13.935 14.149 14.434 14.565 14.750 14.885 15.053 15.343 15.940 16.370 16.637 17.825

## Annular Volume Between One String of Tubing and Casing

Tubing O.D. 2.875 in.

No allowance made for upsets and couplings.

Casing			Capacity			
O.D. in.	Weight lb/ft	I.D. in.	Gallons per Lineal Foot	Cubic Feet per Lineal Foot	Barrels per Lineal Foot	Lineal Feet per Barrel
9 <sup>3</sup> / <sub>4</sub>	59.20	8.560	2.6523	0.3545	0.06314	15.835
9 <sup>7</sup> / <sub>8</sub>	62.80	8.625	2.6979	0.3606	0.06423	15.568
10	33.00	9.384	3.2555	0.4351	0.07751	12.901
	41.50	9.200	3.1160	0.4165	0.07419	13.478
	45.50	9.120	3.0562	0.4085	0.07276	13.742
	50.50	9.016	2.9793	0.3982	0.07093	14.097
	55.50	8.908	2.9003	0.3877	0.06905	14.481
	61.20	8.790	2.8151	0.3763	0.06702	14.919
10 <sup>3</sup> / <sub>4</sub>	32.75	10.192	3.9009	0.5214	0.09287	10.766
	35.75	10.136	3.8544	0.5152	0.09177	10.896
	40.50	10.050	3.7836	0.5057	0.09008	11.100
	45.50	9.950	3.7020	0.4948	0.08814	11.345
	48.00	9.902	3.6631	0.4896	0.08721	11.465
	51.00	9.850	3.6212	0.4840	0.08621	11.598
	54.00	9.784	3.5684	0.4770	0.08495	11.770
	55.50	9.760	3.5492	0.4744	0.08450	11.833
	60.70	9.660	3.4700	0.4638	0.08261	12.103
	65.70	9.560	3.3916	0.4533	0.08075	12.383
	71.10	9.450	3.3063	0.4419	0.07871	12.703
	76.00	9.350	3.2296	0.4317	0.07689	13.005
81.00	9.250	3.1537	0.4215	0.07508	13.318	
11 <sup>3</sup> / <sub>4</sub>	38.00	11.150	4.7351	0.6329	0.11273	8.870
	42.00	11.084	4.6752	0.6249	0.11131	8.983
	47.00	11.000	4.5995	0.6148	0.10951	9.131
	54.00	10.880	4.4924	0.6005	0.10695	9.349
	60.00	10.772	4.3970	0.5877	0.10468	9.552
	65.00	10.682	4.3182	0.5772	0.10281	9.726
	71.00	10.586	4.2349	0.5661	0.10082	9.917





## Annular Volume Between One String of Tubing and Casing

Tubing O.D. 3.500 in.

No allowance made for upsets and couplings.

C

Casing			Capacity			
O.D. in.	Weight lb/ft	I.D. in.	Gallons per Lineal Foot	Cubic Feet per Lineal Foot	Barrels per Lineal Foot	Lineal Feet per Barrel
5 <sup>1/2</sup>	13.00	5.044	0.5382	0.0719	0.01281	78.035
	14.00	5.012	0.5251	0.0701	0.01250	79.986
	15.00	4.974	0.5096	0.0681	0.01213	82.416
	15.50	4.950	0.4999	0.0668	0.01190	84.018
	17.00	4.892	0.4766	0.0637	0.01134	88.124
	20.00	4.778	0.4316	0.0576	0.01027	97.307
	23.00	4.670	0.3900	0.0521	0.00928	107.694
	26.00	4.548	0.3441	0.0460	0.00819	122.054
5 <sup>3/4</sup>	14.00	5.290	0.6419	0.0858	0.01528	65.427
	17.00	5.190	0.5991	0.0800	0.01426	70.096
	19.50	5.090	0.5572	0.0744	0.01326	75.372
	22.50	4.990	0.5161	0.0689	0.01228	81.378
	25.20	4.890	0.4758	0.0636	0.01132	88.272
6	15.00	5.524	0.7451	0.0996	0.01774	56.362
	16.00	5.500	0.7344	0.0981	0.01748	57.191
	17.00	5.450	0.7120	0.0951	0.01695	58.985
	18.00	5.424	0.7005	0.0936	0.01667	59.956
	20.00	5.352	0.6688	0.0894	0.01592	62.794
	23.00	5.240	0.6204	0.0829	0.01477	67.692
	26.00	5.140	0.5781	0.0772	0.01376	72.651
6 <sup>5/8</sup>	13.00	6.255	1.0965	0.1465	0.02610	38.304
	17.00	6.135	1.0358	0.1384	0.02466	40.548
	20.00	6.049	0.9930	0.1327	0.02364	42.293
	22.00	5.989	0.9636	0.1288	0.02294	43.586
	24.00	5.921	0.9305	0.1243	0.02215	45.134
	26.00	5.855	0.8988	0.1201	0.02140	46.726
	28.00	5.791	0.8684	0.1160	0.02067	48.363
	29.00	5.761	0.8543	0.1142	0.02034	49.163
	32.00	5.675	0.8141	0.1088	0.01938	51.586
	34.00	5.595	0.7774	0.1039	0.01850	54.027
	7	17.00	6.538	1.2442	0.1663	0.02962
20.00		6.456	1.2007	0.1605	0.02858	34.979
22.00		6.398	1.1703	0.1564	0.02786	35.888
23.00		6.366	1.1536	0.1542	0.02746	36.406
24.00		6.336	1.1381	0.1521	0.02709	36.904
26.00		6.276	1.1072	0.1480	0.02636	37.933

## Annular Volume Between One String of Tubing and Casing

Tubing O.D. 3.500 in.

No allowance made for upsets and couplings.

Casing			Capacity			
O.D. in.	Weight lb/ft	I.D. in.	Gallons per Lineal Foot	Cubic Feet per Lineal Foot	Barrels per Lineal Foot	Lineal Feet per Barrel
7	28.00	6.214	1.0756	0.1437	0.02560	39.047
	29.00	6.184	1.0604	0.1417	0.02524	39.606
	30.00	6.154	1.0453	0.1397	0.02488	40.178
	32.00	6.094	1.0153	0.1357	0.02417	41.364
	33.70	6.048	0.9925	0.1326	0.02363	42.314
	34.00	6.040	0.9886	0.1321	0.02353	42.483
	35.00	6.004	0.9709	0.1297	0.02311	43.257
	35.30	6.000	0.9690	0.1295	0.02307	43.344
	38.00	5.920	0.9300	0.1243	0.02214	45.158
	40.00	5.836	0.8898	0.1189	0.02118	47.202
	41.00	5.820	0.8821	0.1179	0.02100	47.609
	44.00	5.720	0.8351	0.1116	0.01988	50.294
7 <sup>5</sup> / <sub>8</sub>	20.00	7.125	1.5714	0.2100	0.03741	26.727
	24.00	7.025	1.5137	0.2023	0.03603	27.747
	26.40	6.969	1.4817	0.1980	0.03527	28.346
	29.70	6.875	1.4286	0.1909	0.03401	29.399
	33.70	6.765	1.3674	0.1827	0.03255	30.715
	36.00	6.705	1.3344	0.1783	0.03177	31.474
	38.00	6.655	1.3071	0.1747	0.03112	32.130
	39.00	6.625	1.2909	0.1725	0.03073	32.535
45.30	6.435	1.1896	0.1590	0.02832	35.304	
7 <sup>3</sup> / <sub>4</sub>	46.10	6.560	1.1505	0.1538	0.02739	36.505
8	26.00	7.386	1.7259	0.2307	0.04109	24.334
8 <sup>1</sup> / <sub>8</sub>	28.00	7.485	1.7860	0.2387	0.04252	23.516
	32.00	7.385	1.7253	0.2306	0.04107	24.343
	35.50	7.285	1.6655	0.2226	0.03965	25.218
	39.50	7.185	1.6064	0.2147	0.03824	26.145
8 <sup>5</sup> / <sub>8</sub>	24.00	8.097	2.1751	0.2907	0.05178	19.309
	28.00	8.017	2.1225	0.2837	0.05053	19.788
	32.00	7.921	2.0600	0.2753	0.04904	20.388
	36.00	7.825	1.9984	0.2671	0.04757	21.017
	38.00	7.775	1.9665	0.2628	0.04682	21.357
	40.00	7.725	1.9349	0.2586	0.04606	21.706
	43.00	7.651	1.8885	0.2524	0.04496	22.240
	44.00	7.625	1.8723	0.2502	0.04457	22.432
	48.00	7.537	1.8178	0.2430	0.04328	23.104
	49.00	7.511	1.8019	0.2408	0.04290	23.308



## Annular Volume Between One String of Tubing and Casing

Tubing O.D. 3.500 in.

No allowance made for upsets and couplings.

C

Casing			Capacity			
O.D. in.	Weight lb/ft	I.D. in.	Gallons per Lineal Foot	Cubic Feet per Lineal Foot	Barrels per Lineal Foot	Lineal Feet per Barrel
8 <sup>3</sup> / <sub>4</sub>	49.70	7.636	1.8791	0.2512	0.04474	22.350
9	34.00	8.290	2.3041	0.3080	0.05485	18.228
	38.00	8.196	2.2409	0.2995	0.05335	18.742
	40.00	8.150	2.2102	0.2954	0.05262	19.003
	45.00	8.032	2.1323	0.2850	0.05076	19.697
	50.20	7.910	2.0529	0.2744	0.04887	20.458
	55.00	7.812	1.9901	0.2660	0.04738	21.104
9 <sup>5</sup> / <sub>8</sub>	29.30	9.063	2.8514	0.3811	0.06788	14.729
	32.30	9.001	2.8057	0.3750	0.06680	14.969
	36.00	8.921	2.7472	0.3672	0.06540	15.288
	38.00	8.885	2.7210	0.3637	0.06478	15.435
	40.00	8.835	2.6849	0.3589	0.06392	15.643
	42.00	8.799	2.6590	0.3554	0.06330	15.795
	43.50	8.755	2.6275	0.3512	0.06255	15.985
	47.00	8.681	2.5748	0.3442	0.06130	16.311
	53.50	8.535	2.4723	0.3304	0.05886	16.988
	58.40	8.435	2.4030	0.3212	0.05721	17.478
	61.10	8.375	2.3619	0.3157	0.05623	17.782
71.80	8.125	2.1936	0.2932	0.05222	19.146	
9 <sup>3</sup> / <sub>4</sub>	59.20	8.560	2.4897	0.3328	0.05927	16.869
9 <sup>7</sup> / <sub>8</sub>	62.80	8.625	2.5353	0.3389	0.06036	16.566
10	33.00	9.384	3.0930	0.4134	0.07364	13.579
	41.50	9.200	2.9535	0.3948	0.07031	14.220
	45.50	9.120	2.8937	0.3868	0.06889	14.514
	50.50	9.016	2.8167	0.3765	0.06706	14.911
	55.50	8.908	2.7377	0.3659	0.06518	15.341
	61.20	8.790	2.6525	0.3545	0.06315	15.834
10 <sup>3</sup> / <sub>4</sub>	32.75	10.192	3.7383	0.4997	0.08900	11.235
	35.75	10.136	3.6919	0.4935	0.08790	11.376
	40.50	10.050	3.6211	0.4840	0.08621	11.599
	45.50	9.950	3.5395	0.4731	0.08427	11.866
	48.00	9.902	3.5006	0.4679	0.08334	11.998
	51.00	9.850	3.4587	0.4623	0.08234	12.143
	54.00	9.784	3.4058	0.4552	0.08108	12.332

## Annular Volume Between One String of Tubing and Casing

Tubing O.D. 3.500 in.

No allowance made for upsets and couplings.

Casing			Capacity			
O.D. in.	Weight lb/ft	I.D. in.	Gallons per Lineal Foot	Cubic Feet per Lineal Foot	Barrels per Lineal Foot	Lineal Feet per Barrel
10 <sup>3</sup> / <sub>4</sub>	55.50	9.760	3.3867	0.4527	0.08063	12.401
	60.70	9.660	3.3074	0.4421	0.07874	12.698
	65.70	9.560	3.2290	0.4316	0.07688	13.007
	71.10	9.450	3.1437	0.4202	0.07484	13.360
	76.00	9.350	3.0670	0.4099	0.07302	13.694
	81.00	9.250	2.9911	0.3998	0.07121	14.041
11 <sup>3</sup> / <sub>4</sub>	38.00	11.150	4.5725	0.6112	0.10886	9.185
	42.00	11.084	4.5126	0.6032	0.10744	9.307
	47.00	11.000	4.4370	0.5931	0.10563	9.466
	54.00	10.880	4.3298	0.5788	0.10308	9.700
	60.00	10.772	4.2344	0.5660	0.10081	9.918
	65.00	10.682	4.1556	0.5555	0.09894	10.106
71.00	10.586	4.0723	0.5443	0.09695	10.313	
11 <sup>7</sup> / <sub>8</sub>	71.80	10.711	4.1810	0.5589	0.09954	10.045
12	40.00	11.384	4.7876	0.6400	0.11398	8.772
13	43.00	12.130	5.5033	0.7356	0.13102	7.631
	53.00	11.970	5.3460	0.7146	0.12728	7.856
	40.00	12.438	5.8121	0.7769	0.13837	7.226
	45.00	12.360	5.7331	0.7663	0.13650	7.325
	50.00	12.282	5.6547	0.7559	0.13463	7.427
	54.00	12.220	5.5927	0.7476	0.13315	7.509
	48.00	12.715	6.0963	0.8149	0.14514	6.889
54.50	12.615	5.9930	0.8011	0.14268	7.008	
13 <sup>3</sup> / <sub>8</sub>	61.00	12.515	5.8905	0.7874	0.14024	7.130
	68.00	12.415	5.7887	0.7738	0.13782	7.255
	72.00	12.347	5.7200	0.7646	0.13618	7.342
	77.00	12.275	5.6477	0.7549	0.13446	7.436
	83.00	12.175	5.5480	0.7416	0.13209	7.570
	85.00	12.159	5.5321	0.7395	0.13171	7.592
	92.00	12.031	5.4057	0.7226	0.12870	7.769
98.00	11.937	5.3138	0.7103	0.12651	7.904	

C

## Annular Volume Between One String of Tubing and Casing

Tubing O.D. 3.500 in.

No allowance made for upsets and couplings.

C

Casing			Capacity			
O.D. in.	Weight lb/ft	I.D. in.	Gallons per Lineal Foot	Cubic Feet per Lineal Foot	Barrels per Lineal Foot	Lineal Feet per Barrel
8 <sup>3</sup> / <sub>4</sub>	49.70	7.636	1.8791	0.2512	0.04474	22.350
9	34.00	8.290	2.3041	0.3080	0.05485	18.228
	38.00	8.196	2.2409	0.2995	0.05335	18.742
	40.00	8.150	2.2102	0.2954	0.05262	19.003
	45.00	8.032	2.1323	0.2850	0.05076	19.697
	50.20	7.910	2.0529	0.2744	0.04887	20.458
	55.00	7.812	1.9901	0.2660	0.04738	21.104
9 <sup>5</sup> / <sub>8</sub>	29.30	9.063	2.8514	0.3811	0.06788	14.729
	32.30	9.001	2.8057	0.3750	0.06680	14.969
	36.00	8.921	2.7472	0.3672	0.06540	15.288
	38.00	8.885	2.7210	0.3637	0.06478	15.435
	40.00	8.835	2.6849	0.3589	0.06392	15.643
	42.00	8.799	2.6590	0.3554	0.06330	15.795
	43.50	8.755	2.6275	0.3512	0.06255	15.985
	47.00	8.681	2.5748	0.3442	0.06130	16.311
	53.50	8.535	2.4723	0.3304	0.05886	16.988
	58.40	8.435	2.4030	0.3212	0.05721	17.478
	61.10	8.375	2.3619	0.3157	0.05623	17.782
71.80	8.125	2.1936	0.2932	0.05222	19.146	
9 <sup>3</sup> / <sub>4</sub>	59.20	8.560	2.4897	0.3328	0.05927	16.869
9 <sup>7</sup> / <sub>8</sub>	62.80	8.625	2.5353	0.3389	0.06036	16.566
10	33.00	9.384	3.0930	0.4134	0.07364	13.579
	41.50	9.200	2.9535	0.3948	0.07031	14.220
	45.50	9.120	2.8937	0.3868	0.06889	14.514
	50.50	9.016	2.8167	0.3765	0.06706	14.911
	55.50	8.908	2.7377	0.3659	0.06518	15.341
	61.20	8.790	2.6525	0.3545	0.06315	15.834
10 <sup>3</sup> / <sub>4</sub>	32.75	10.192	3.7383	0.4997	0.08900	11.235
	35.75	10.136	3.6919	0.4935	0.08790	11.376
	40.50	10.050	3.6211	0.4840	0.08621	11.599
	45.50	9.950	3.5395	0.4731	0.08427	11.866
	48.00	9.902	3.5006	0.4679	0.08334	11.998
	51.00	9.850	3.4587	0.4623	0.08234	12.143
	54.00	9.784	3.4058	0.4552	0.08108	12.332

## Annular Volume Between One String of Tubing and Casing

Tubing O.D. 3.500 in.

No allowance made for upsets and couplings.

Casing			Capacity			
O.D. in.	Weight lb/ft	I.D. in.	Gallons per Lineal Foot	Cubic Feet per Lineal Foot	Barrels per Lineal Foot	Lineal Feet per Barrel
10 <sup>3/4</sup>	55.50	9.760	3.3867	0.4527	0.08063	12.401
	60.70	9.660	3.3074	0.4421	0.07874	12.698
	65.70	9.560	3.2290	0.4316	0.07688	13.007
	71.10	9.450	3.1437	0.4202	0.07484	13.360
	76.00	9.350	3.0670	0.4099	0.07302	13.694
	81.00	9.250	2.9911	0.3998	0.07121	14.041
11 <sup>3/4</sup>	38.00	11.150	4.5725	0.6112	0.10886	9.185
	42.00	11.084	4.5126	0.6032	0.10744	9.307
	47.00	11.000	4.4370	0.5931	0.10563	9.466
	54.00	10.880	4.3298	0.5788	0.10308	9.700
	60.00	10.772	4.2344	0.5660	0.10081	9.918
	65.00	10.682	4.1556	0.5555	0.09894	10.106
71.00	10.586	4.0723	0.5443	0.09695	10.313	
11 <sup>7/8</sup>	71.80	10.711	4.1810	0.5589	0.09954	10.045
12	40.00	11.384	4.7876	0.6400	0.11398	8.772
13	43.00	12.130	5.5033	0.7356	0.13102	7.631
	53.00	11.970	5.3460	0.7146	0.12728	7.856
	40.00	12.438	5.8121	0.7769	0.13837	7.226
	45.00	12.360	5.7331	0.7663	0.13650	7.325
	50.00	12.282	5.6547	0.7559	0.13463	7.427
	54.00	12.220	5.5927	0.7476	0.13315	7.509
	48.00	12.715	6.0963	0.8149	0.14514	6.889
54.50	12.615	5.9930	0.8011	0.14268	7.008	
13 <sup>3/8</sup>	61.00	12.515	5.8905	0.7874	0.14024	7.130
	68.00	12.415	5.7887	0.7738	0.13782	7.255
	72.00	12.347	5.7200	0.7646	0.13618	7.342
	77.00	12.275	5.6477	0.7549	0.13446	7.436
	83.00	12.175	5.5480	0.7416	0.13209	7.570
	85.00	12.159	5.5321	0.7395	0.13171	7.592
	92.00	12.031	5.4057	0.7226	0.12870	7.769
98.00	11.937	5.3138	0.7103	0.12651	7.904	

C

## Annular Volume Between One String of Tubing and Casing

Tubing O.D. 4.000 in.

No allowance made for upsets and couplings.

C

Casing			Capacity			
O.D. in.	Weight lb/ft	I.D. in.	Gallons per Lineal Foot	Cubic Feet per Lineal Foot	Barrels per Lineal Foot	Lineal Feet per Barrel
5 <sup>1/2</sup>	13.00	5.044	0.3852	0.0514	0.00917	109.028
	14.00	5.012	0.3721	0.0497	0.00885	112.875
	15.00	4.974	0.3566	0.0476	0.00849	117.776
	15.50	4.950	0.3469	0.0463	0.00825	121.075
	17.00	4.892	0.3236	0.0432	0.00770	129.788
	20.00	4.778	0.2786	0.0372	0.00663	150.739
	23.00	4.670	0.2370	0.0316	0.00564	177.218
	26.00	4.548	0.1911	0.0255	0.00455	219.764
5 <sup>3/4</sup>	14.00	5.290	0.4889	0.0653	0.01164	85.900
	17.00	5.190	0.4461	0.0596	0.01062	94.132
	19.50	5.090	0.4042	0.0540	0.00962	103.899
	22.50	4.990	0.3631	0.0485	0.00864	115.666
	25.20	4.890	0.3228	0.0431	0.00768	130.109
6	15.00	5.524	0.5921	0.0791	0.01409	70.924
	16.00	5.500	0.5814	0.0777	0.01384	72.241
	17.00	5.450	0.5590	0.0747	0.01331	75.128
	18.00	5.424	0.5475	0.0731	0.01303	76.710
	20.00	5.352	0.5158	0.0689	0.01228	81.418
	23.00	5.240	0.4674	0.0624	0.01112	89.847
6 <sup>5/8</sup>	13.00	6.255	0.9435	0.1261	0.02246	44.516
	17.00	6.135	0.8828	0.1180	0.02101	47.575
	20.00	6.049	0.8400	0.1123	0.02000	49.996
	22.00	5.989	0.8106	0.1083	0.01929	51.813
	24.00	5.921	0.7775	0.1039	0.01851	54.015
	26.00	5.855	0.7458	0.0997	0.01775	56.312
	28.00	5.791	0.7154	0.0956	0.01703	58.705
	29.00	5.761	0.7013	0.0937	0.01669	59.889
	32.00	5.675	0.6611	0.0883	0.01574	63.523
	34.00	5.595	0.6244	0.0834	0.01486	67.266
7	17.00	6.538	1.0912	0.1458	0.02598	38.490
	20.00	6.456	1.0477	0.1400	0.02494	40.087
	22.00	6.398	1.0173	0.1359	0.02422	41.286
	23.00	6.366	1.0006	0.1337	0.02382	41.973
	24.00	6.336	0.9851	0.1316	0.02345	42.636
	26.00	6.276	0.9542	0.1275	0.02271	44.015
	28.00	6.214	0.9226	0.1233	0.02196	45.522

## Annular Volume Between One String of Tubing and Casing

Tubing O.D. 4.000 in.

No allowance made for upsets and couplings.

Casing			Capacity			
O.D. in.	Weight lb/ft	I.D. in.	Gallons per Lineal Foot	Cubic Feet per Lineal Foot	Barrels per Lineal Foot	Lineal Feet per Barrel
7	29.00	6.184	0.9074	0.1213	0.02160	46.283
	30.00	6.154	0.8923	0.1192	0.02124	47.067
	32.00	6.094	0.8623	0.1152	0.02053	48.703
	33.70	6.048	0.8395	0.1122	0.01998	50.025
	34.00	6.040	0.8356	0.1117	0.01989	50.261
	35.00	6.004	0.8179	0.1093	0.01947	51.348
	35.30	6.000	0.8160	0.1090	0.01942	51.472
	38.00	5.920	0.7770	0.1038	0.01850	54.049
	40.00	5.836	0.7368	0.0984	0.01754	57.004
	41.00	5.820	0.7291	0.0974	0.01736	57.599
44.00	5.720	0.6821	0.0911	0.01624	61.575	
7 <sup>5</sup> / <sub>8</sub>	20.00	7.125	1.4184	0.1896	0.03377	29.610
	24.00	7.025	1.3607	0.1818	0.03239	30.867
	26.40	6.969	1.3287	0.1776	0.03163	31.610
	29.70	6.875	1.2756	0.1705	0.03037	32.925
	33.70	6.765	1.2144	0.1623	0.02891	34.585
	36.00	6.705	1.1814	0.1579	0.02812	35.550
	38.00	6.655	1.1541	0.1542	0.02747	36.390
	39.00	6.625	1.1379	0.1521	0.02709	36.909
	45.30	6.435	1.0366	0.1385	0.02468	40.514
7 <sup>3</sup> / <sub>4</sub>	46.10	6.560	0.9975	0.1333	0.02375	42.104
8	26.00	7.386	1.5729	0.2102	0.03745	26.701
8 <sup>1</sup> / <sub>8</sub>	28.00	7.485	1.6330	0.2182	0.03888	25.719
	32.00	7.385	1.5723	0.2101	0.03743	26.712
	35.50	7.285	1.5125	0.2021	0.03601	27.769
	39.50	7.185	1.4534	0.1942	0.03460	28.897
8 <sup>5</sup> / <sub>8</sub>	24.00	8.097	2.0221	0.2703	0.04814	20.771
	28.00	8.017	1.9695	0.2632	0.04689	21.325
	32.00	7.921	1.9070	0.2549	0.04540	22.023
	36.00	7.825	1.8454	0.2466	0.04393	22.759
	38.00	7.775	1.8135	0.2424	0.04317	23.159
	40.00	7.725	1.7819	0.2382	0.04242	23.570
	43.00	7.651	1.7355	0.2320	0.04132	24.200
	44.00	7.625	1.7193	0.2298	0.04093	24.428
	48.00	7.537	1.6648	0.2225	0.03963	25.227
	49.00	7.511	1.6489	0.2204	0.03925	25.471





## Annular Volume Between One String of Tubing and Casing

Tubing O.D. 4.000 in.

No allowance made for upsets and couplings.

C

Casing			Capacity			
O.D. in.	Weight lb/ft	I.D. in.	Gallons per Lineal Foot	Cubic Feet per Lineal Foot	Barrels per Lineal Foot	Lineal Feet per Barrel
8 <sup>3</sup> / <sub>4</sub>	49.70	7.636	1.7261	0.2307	0.04109	24.331
9	34.00	8.290	2.1511	0.2875	0.05121	19.525
	38.00	8.196	2.0879	0.2791	0.04971	20.116
	40.00	8.150	2.0572	0.2750	0.04898	20.416
	45.00	8.032	1.9793	0.2645	0.04712	21.219
	50.20	7.910	1.8999	1.8999	0.2539	0.04523
9 <sup>5</sup> / <sub>8</sub>	55.00	7.812	1.8371	0.2455	0.04373	22.862
	29.30	9.063	2.6984	0.3607	0.06424	15.565
	32.30	9.001	2.6527	0.3546	0.06315	15.833
	36.00	8.921	2.5942	0.3467	0.06176	16.190
	38.00	8.885	2.5680	0.3432	0.06114	16.355
	40.00	8.835	2.5319	0.3384	0.06028	16.588
	42.00	8.799	2.5060	0.3349	0.05966	16.760
	43.50	8.755	2.4745	0.3307	0.05891	16.973
	47.00	8.681	2.4218	0.3237	0.05766	17.342
	53.50	8.535	2.3193	0.3100	0.05522	18.109
9 <sup>3</sup> / <sub>4</sub>	58.40	8.435	2.2500	0.3007	0.05357	18.666
	61.10	8.375	2.2089	0.2952	0.05259	19.014
9 <sup>7</sup> / <sub>8</sub>	62.80	8.625	3.3823	0.3184	0.05672	17.630
10	71.80	8.125	2.0406	0.2727	0.04858	20.582
	33.00	9.384	2.9400	0.3930	0.06999	14.286
	41.50	9.200	2.8005	0.3743	0.06667	14.997
	45.50	9.120	2.7407	0.3663	0.06525	15.324
	50.50	9.016	2.6637	0.3560	0.06342	15.767
10 <sup>3</sup> / <sub>4</sub>	55.50	8.908	2.5847	0.3455	0.06154	16.249
	61.20	8.790	2.4995	0.3341	0.05951	16.803
	32.75	10.192	3.5853	0.4792	0.08536	11.714
	35.75	10.136	3.5389	0.4730	0.08425	11.868
	40.50	10.050	3.4681	0.4636	0.08257	12.110
	45.50	9.950	3.3865	0.4526	0.08062	12.402
	48.00	9.902	3.3476	0.4474	0.07970	12.546
51.00	9.850	3.3057	0.4418	0.07870	12.705	
54.00	9.784	3.2528	0.4348	0.07744	12.912	
55.50	9.760	3.2337	0.4322	0.07699	12.988	

## Annular Volume Between One String of Tubing and Casing

Tubing O.D. 4.000 in.

No allowance made for upsets and couplings.

Casing			Capacity			
O.D. in.	Weight lb/ft	I.D. in.	Gallons per Lineal Foot	Cubic Feet per Lineal Foot	Barrels per Lineal Foot	Lineal Feet per Barrel
10 <sup>3</sup> / <sub>4</sub>	60.70	9.660	3.1544	0.4216	0.07510	13.314
	65.70	9.560	3.0760	0.4111	0.07323	13.654
	71.10	9.450	2.9907	0.3997	0.07120	14.043
	76.00	9.350	2.9140	0.3895	0.06937	14.413
	81.00	9.250	2.8381	0.3793	0.06757	14.798
11 <sup>3</sup> / <sub>4</sub>	38.00	11.150	4.4195	0.5907	0.10522	9.503
	42.00	11.084	4.3596	0.5827	0.10379	9.634
	47.00	11.000	4.2840	0.5726	0.10199	9.804
	54.00	10.880	4.1768	0.5583	0.09944	10.055
	60.00	10.772	4.0814	0.5455	0.09717	10.290
	65.00	10.682	4.0026	0.5350	0.09529	10.493
71.00	10.586	3.9193	0.5239	0.09331	10.716	
11 <sup>7</sup> / <sub>8</sub>	71.80	10.711	4.0280	0.5384	0.09590	10.427
12	40.00	11.384	4.6346	0.6195	0.11034	9.062
12 <sup>3</sup> / <sub>4</sub>	43.00	12.130	5.3503	0.7152	0.12738	7.850
	53.00	11.970	5.1930	0.6941	0.12364	8.087
13	40.00	12.438	5.6591	0.7564	0.13473	7.421
	45.00	12.360	5.5801	0.7459	0.13285	7.526
	50.00	12.282	5.5017	0.7354	0.13099	7.634
	54.00	12.220	5.4397	0.7271	0.12951	7.721
13 <sup>3</sup> / <sub>8</sub>	48.00	12.715	5.9433	0.7944	0.14150	7.066
	54.50	12.615	5.8400	0.7806	0.13904	7.191
	61.00	12.515	5.7375	0.7669	0.13660	7.320
	68.00	12.415	5.6357	0.7533	0.13418	7.452
	72.00	12.347	5.5670	0.7441	0.13254	7.544
	77.00	12.275	5.4947	0.7345	0.13082	7.643
	83.00	12.175	5.3950	0.7211	0.12844	7.785
	85.00	12.159	5.3791	0.7190	0.12807	7.808
	92.00	12.031	5.2527	0.7021	0.12506	7.995
	98.00	11.937	5.1608	0.6898	0.12287	8.138



## Annular Volume Between One String of Tubing and Casing

Tubing O.D. 4.500 in.

No allowance made for upsets and couplings.

C

Casing			Capacity			
O.D. in.	Weight lb/ft	I.D. in.	Gallons per Lineal Foot	Cubic Feet per Lineal Foot	Barrels per Lineal Foot	Lineal Feet per Barrel
6	15.00	5.524	0.4187	0.0559	0.00997	100.290
	16.00	5.500	0.4080	0.0545	0.00971	102.944
	17.00	5.450	0.3856	0.0515	0.00918	108.906
	18.00	5.424	0.3741	0.0500	0.00890	112.264
	20.00	5.352	0.3424	0.0457	0.00815	122.641
	23.00	5.240	0.2940	0.0393	0.00700	142.827
	26.00	5.140	0.2517	0.0336	0.00599	166.857
6 <sup>5/8</sup>	13.00	6.255	0.7701	0.1029	0.01833	54.539
	17.00	6.135	0.7094	0.0948	0.01689	59.203
	20.00	6.049	0.6666	0.0891	0.01587	62.999
	22.00	5.989	0.6372	0.0851	0.01517	65.913
	24.00	5.921	0.6041	0.0807	0.01438	69.518
	26.00	5.855	0.5724	0.0765	0.01362	73.368
	28.00	5.791	0.5420	0.0724	0.01290	77.485
	29.00	5.761	0.5279	0.0705	0.01256	79.560
	32.00	5.675	0.4877	0.0652	0.01161	86.105
	34.00	5.595	0.4510	0.0602	0.01073	93.128
7	17.00	6.538	0.9178	0.1226	0.02185	45.762
	20.00	6.456	0.8743	0.1168	0.02081	48.037
	22.00	6.398	0.8439	0.1128	0.02009	49.768
	23.00	6.366	0.8272	0.1105	0.01969	50.771
	24.00	6.336	0.8117	0.1085	0.01932	51.744
	26.00	6.276	0.7808	0.1043	0.01859	53.789
	28.00	6.214	0.7492	0.1001	0.01783	56.058
	29.00	6.184	0.7340	0.0981	0.01747	57.217
	30.00	6.154	0.7189	0.0961	0.01711	58.418
	32.00	6.094	0.6889	0.0921	0.01640	60.961
	33.70	6.048	0.6661	0.0890	0.01586	63.046
	34.00	6.040	0.6622	0.0885	0.01576	63.422
	35.00	6.004	0.6445	0.0861	0.01534	65.162
	35.30	6.000	0.6426	0.0859	0.01529	65.361
	38.00	5.920	0.6036	0.0806	0.01437	69.573
	40.00	5.836	0.5634	0.0753	0.01341	74.549
41.00	5.820	0.5557	0.0742	0.01323	75.569	
44.00	5.720	0.5087	0.0680	0.0121	82.564	

## Annular Volume Between One String of Tubing and Casing

Tubing O.D. 4.500 in.

No allowance made for upsets and couplings.

Casing			Capacity			
O.D. in.	Weight lb/ft	I.D. in.	Gallons per Lineal Foot	Cubic Feet per Lineal Foot	Barrels per Lineal Foot	Lineal Feet per Barrel
7 <sup>5</sup> / <sub>8</sub>	20.00	7.125	1.2450	0.1664	0.02964	33.734
	24.00	7.025	1.1873	0.1587	0.02826	35.375
	26.40	6.969	1.1553	0.1544	0.02750	36.354
	29.70	6.875	1.1022	0.1473	0.02624	38.105
	33.70	6.765	1.0410	0.1391	0.02479	40.346
	36.00	6.705	1.0080	0.1347	0.02400	41.665
	38.00	6.655	0.9807	0.1311	0.02335	42.823
	39.00	6.625	0.9645	0.1289	0.02296	43.545
	45.30	6.435	0.8632	0.1154	0.02055	48.652
7 <sup>3</sup> / <sub>4</sub>	46.10	6.560	0.8241	0.1101	0.01962	50.963
8	26.00	7.386	1.3995	0.1870	0.03332	30.010
8 <sup>1</sup> / <sub>8</sub>	28.00	7.485	1.4596	0.1951	0.03475	28.775
	32.00	7.385	1.3989	0.1870	0.03330	30.023
	35.50	7.285	1.3391	0.1790	0.03188	31.365
	39.50	7.185	1.2800	0.1711	0.03047	32.811
8 <sup>5</sup> / <sub>8</sub>	24.00	8.097	1.8487	0.2471	0.04401	22.719
	28.00	8.017	1.7961	0.2400	0.04276	23.384
	32.00	7.921	1.7336	0.2317	0.04127	24.226
	36.00	7.825	1.6720	0.2235	0.03980	25.120
	38.00	7.775	1.6401	0.2192	0.03905	25.607
	40.00	7.725	1.6085	0.2150	0.03829	26.110
	43.00	7.651	1.5621	0.2088	0.03719	26.886
	44.00	7.625	1.5459	0.2066	0.03680	27.168
	48.00	7.537	1.4914	0.1993	0.03551	28.160
49.00	7.511	1.4755	0.1972	0.03513	28.465	
8 <sup>3</sup> / <sub>4</sub>	49.70	7.636	1.5527	0.2075	0.03697	27.048
9	34.00	8.290	1.9777	0.2643	0.04708	21.236
	38.00	8.196	1.9145	0.2559	0.04558	21.938
	40.00	8.150	1.8838	0.2518	0.04485	22.295
	45.00	8.032	1.8059	0.2414	0.04299	23.257
	50.20	7.910	1.7265	0.2308	0.04110	24.326
	55.00	7.812	1.6637	0.2223	0.03961	25.245
9 <sup>5</sup> / <sub>8</sub>	29.30	9.063	2.5250	0.3375	0.06011	16.633
	32.30	9.001	2.4793	0.3314	0.05903	16.940
	36.00	8.921	2.4208	0.3236	0.05763	17.349



## Annular Volume Between One String of Tubing and Casing

Tubing O.D. 4.500 in.

No allowance made for upsets and couplings.

C

Casing			Capacity			
O.D. in.	Weight lb/ft	I.D. in.	Gallons per Lineal Foot	Cubic Feet per Lineal Foot	Barrels per Lineal Foot	Lineal Feet per Barrel
9 <sup>5</sup> / <sub>8</sub>	42.00	8.799	2.3326	0.3118	0.05553	18.005
	43.50	8.755	2.3011	0.3076	0.05478	18.252
	47.00	8.681	2.2484	0.3005	0.05353	18.679
	53.50	8.535	2.1459	0.2868	0.05109	19.572
	58.40	8.435	2.0766	0.2776	0.04944	20.225
	61.10	8.375	2.0355	0.2721	0.04846	20.633
	71.80	8.125	1.8672	0.2496	0.04445	22.493
9 <sup>3</sup> / <sub>4</sub>	59.20	8.560	2.1633	0.2891	0.05150	19.414
9 <sup>7</sup> / <sub>8</sub>	62.80	8.625	2.2089	0.2952	0.05259	19.014
10	33.00	9.384	2.7666	0.3698	0.06587	15.181
	41.50	9.200	2.6271	0.3511	0.06254	15.987
	45.50	9.120	2.5673	0.3431	0.06112	16.359
	50.50	9.016	2.4903	0.3329	0.05929	6.865
	55.50	8.908	2.4113	0.3223	0.05741	17.417
	61.20	8.790	2.3261	0.3109	0.05538	18.055
10 <sup>3</sup> / <sub>4</sub>	32.75	10.192	3.4119	0.4561	0.08123	12.309
	35.75	10.136	3.3655	0.4498	0.08012	12.479
	40.50	10.050	3.2947	0.4404	0.07844	12.748
	45.50	9.950	3.2131	0.4295	0.07650	13.071
	48.00	9.902	3.1742	0.4243	0.07557	13.231
	51.00	9.850	3.1323	0.4187	0.07457	13.408
	54.00	9.784	3.0794	0.4116	0.07331	13.639
	55.50	9.760	3.0603	0.4090	0.07286	13.724
	60.70	9.660	2.9810	0.3984	0.07097	14.089
	65.70	9.560	2.9026	0.3880	0.06910	14.469
	71.10	9.450	2.8173	0.3766	0.06707	14.908
	76.00	9.350	2.7406	0.3663	0.06525	15.325
81.00	9.250	2.6647	0.3562	0.06344	15.761	
11 <sup>3</sup> / <sub>4</sub>	38.00	11.150	4.2461	0.5676	0.10109	9.891
	42.00	11.084	4.1862	0.5596	0.09967	10.033
	47.00	11.000	4.1106	0.5494	0.09786	10.217
	54.00	10.880	4.0034	0.5351	0.09531	10.491
	60.00	10.772	3.9080	0.5224	0.09304	10.747
	65.00	10.682	3.8292	0.5118	0.09117	10.968
	71.00	10.586	3.7459	0.5007	0.08918	11.212

## Annular Volume Between One String of Tubing and Casing

Tubing O.D. 4.500 in.

No allowance made for upsets and couplings.

Casing			Capacity			
O.D. in.	Weight lb/ft	I.D. in.	Gallons per Lineal Foot	Cubic Feet per Lineal Foot	Barrels per Lineal Foot	Lineal Feet per Barrel
11 <sup>7</sup> / <sub>8</sub>	71.80	10.711	3.8546	0.5152	0.09177	10.896
12	40.00	11.384	4.4612	0.5963	0.10621	9.414
12 <sup>3</sup> / <sub>4</sub>	43.00	12.130	5.1769	0.6920	0.12325	8.113
	53.00	11.970	5.0196	0.6710	0.11951	8.367
13	40.00	12.438	5.4857	0.7333	0.13060	7.656
	45.00	12.360	5.4067	0.7227	0.12872	7.768
	50.00	12.282	5.3283	0.7122	0.12686	7.882
	54.00	12.220	5.2663	0.7039	0.12538	7.975
13 <sup>3</sup> / <sub>8</sub>	48.00	12.715	5.7699	0.7713	0.13737	7.279
	54.50	12.615	5.6666	0.7574	0.13491	7.412
	61.00	12.515	5.5641	0.7437	0.13247	7.548
	68.00	12.415	5.4623	0.7301	0.13005	7.689
	72.00	12.347	5.3936	0.7210	0.12841	7.787
14 <sup>3</sup> / <sub>8</sub>	77.00	12.275	5.3213	0.7113	0.12669	7.892
	83.00	12.175	5.2216	0.6980	0.12432	8.043
	85.00	12.159	5.2057	0.6958	0.12394	8.068
	92.00	12.031	5.0793	0.6789	0.12093	8.268
	98.00	11.937	4.9874	0.6667	0.11874	8.421
13 <sup>1</sup> / <sub>2</sub>	81.40	12.340	5.3866	0.7200	0.1284	7.797
13 <sup>5</sup> / <sub>8</sub>	88.20	12.375	5.4219	0.7247	0.12908	7.746
14	50.00	13.344	6.4387	0.8607	0.15329	6.523
16	55.00	15.375	8.8185	1.1788	0.20995	4.762
	65.00	15.250	8.6623	1.1579	0.20624	4.848
	70.00	15.198	8.5977	1.1493	0.20470	4.885
	75.00	15.125	8.5074	1.1372	0.20255	4.937
	84.00	15.010	8.3660	1.1183	0.19918	5.020
	109.00	14.688	7.9758	1.0661	0.18989	5.266

C

## Annular Volume Between One String of Tubing and Casing

Tubing O.D. 4.500 in.

No allowance made for upsets and couplings.

Casing			Capacity			
O.D. in.	Weight lb/ft	I.D. in.	Gallons per Lineal Foot	Cubic Feet per Lineal Foot	Barrels per Lineal Foot	Lineal Feet per Barrel
18	78.00	17.194	11.2356	1.5019	0.26750	3.738
	87.50	17.088	11.0873	1.4821	0.26397	3.788
	96.50	16.986	10.9455	1.4631	0.26060	3.837
18 <sup>5/8</sup>	73.09	17.875	12.2100	1.6321	0.29070	3.439
	78.00	17.855	12.1808	1.6282	0.29001	3.448
	87.50	17.755	12.0355	1.6088	0.28655	3.489
	96.50	17.655	11.8911	1.5895	0.28311	3.532
20	90.00	19.166	14.1610	1.8930	0.33715	2.965
	94.00	19.124	14.0954	1.8842	0.33559	2.979
	106.50	19.000	13.9025	1.8584	0.33100	3.021
	133.00	18.730	13.4869	1.8028	0.32110	3.114

C

## Annular Volume Between Two Strings of Tubing and Casing

Tubing O.D. 1.050 in.

No allowance made for upsets and couplings.

Casing			Capacity			
O.D. in.	Weight lb/ft	I.D. in.	Gallons per Lineal Foot	Cubic Feet per Lineal Foot	Barrels per Lineal Foot	Lineal Feet per Barrel
4 <sup>1/2</sup>	9.50	4.090	.5925	.0792	.0141	70.88
	10.50	4.052	.5799	.0775	.0138	72.42
	11.60	4.000	.5628	.0752	.0134	74.62
	12.60	3.958	.5492	.0734	.0131	76.48
	13.50	3.920	.5370	.0718	.0128	78.21
	15.10	3.826	.5023	.0678	.0121	82.80
	16.60	3.754	.4850	.0648	.0115	86.60
	17.70	3.697	.5521	.0625	.0111	89.80
18.80	3.640	.4506	.0602	.0107	93.21	
4 <sup>3/4</sup>	16.00	4.082	.5899	.0789	.0140	71.20
5	11.50	4.560	.7584	.1014	.0181	55.38
	13.00	4.494	.7340	.0981	.0175	57.22
	15.00	4.408	.7028	.0940	.0167	59.76
	18.00	4.276	.6560	.0877	.0156	64.02
	20.30	4.184	.6243	.0835	.0149	67.29
	21.00	4.154	.6141	.0821	.0146	68.40
	23.20	4.044	.5773	.0772	.0137	72.76
5 <sup>1/2</sup>	13.00	5.044	.9481	.1267	.0226	44.30
	14.00	5.012	.9349	.1250	.0223	44.92
	15.00	4.974	.9195	.1229	.0219	45.68
	15.50	4.950	.9097	.1216	.0217	46.17
	17.00	4.892	.8864	.1185	.0211	47.38
	20.00	4.778	.8415	.1125	.0200	49.91
	23.00	4.670	.7998	.1069	.0190	52.51
	26.00	4.548	.7539	.1008	.0180	55.72
5 <sup>3/4</sup>	14.00	5.290	1.0518	.1406	.0250	39.93
	17.00	5.190	1.0090	.1349	.0240	41.62
	19.50	5.090	.9671	.1293	.0230	43.43
	22.50	4.990	.9260	.1238	.0220	45.36
	25.20	4.890	.8856	.1184	.0211	47.43
6	15.00	5.524	1.1550	.1544	.0275	36.36
	16.00	5.500	1.1442	.1530	.0272	36.71
	17.00	5.450	1.1219	.1500	.0267	37.44
	18.00	5.424	1.1104	.1484	.0264	37.83
	20.00	5.352	1.0787	.1427	.0257	38.94
	23.00	5.240	1.0303	.1377	.0245	40.76
	26.00	5.140	.9846	.1316	.0234	42.66





## Annular Volume Between Two Strings of Tubing and Casing

Tubing O.D. 1.050 in.

No allowance made for upsets and couplings.

C

Casing			Capacity			
O.D. in.	Weight lb/ft	I.D. in.	Gallons per Lineal Foot	Cubic Feet per Lineal Foot	Barrels per Lineal Foot	Lineal Feet per Barrel
6 <sup>5</sup> / <sub>8</sub>	13.00	6.255	1.5063	.2014	.0359	27.88
	17.00	6.135	1.4457	.1933	.0344	29.05
	20.00	6.049	1.4029	.1875	.0334	29.94
	22.00	5.989	1.3735	.1836	.0327	30.58
	24.00	5.921	1.3404	.1792	.0319	31.33
	26.00	5.855	1.3087	.1749	.0312	32.09
	28.00	5.791	1.2783	.1709	.0304	32.86
	29.00	5.761	1.2641	.1690	.0301	33.22
	32.00	5.675	1.2240	.1636	.0291	34.31
	34.00	5.595	1.1872	1.1872	.1587	.0283
7	17.00	6.538	1.6540	.2211	.0394	25.39
	20.00	6.456	1.6106	.2153	.0383	26.08
	22.00	6.398	1.5802	.2112	.0376	26.58
	23.00	6.366	1.5635	.2090	.0372	26.86
	24.00	6.336	1.5479	.2069	.0369	27.13
	26.00	6.276	1.5171	.6592	.0361	27.68
	28.00	6.214	1.4855	.1986	.0354	28.27
	29.00	6.184	1.4703	.1966	.0350	28.57
	30.00	5.154	1.4552	.1945	.0346	28.86
	32.00	6.094	1.4252	.1905	.0339	29.47
	33.70	6.048	1.4024	.1875	.0334	29.95
	34.00	6.040	1.3985	.1869	.0333	30.03
	35.00	6.004	1.3808	.1846	.0329	30.42
	35.30	6.000	1.3788	.1843	.0328	30.46
	38.00	5.920	1.3399	.1791	.0319	31.35
	40.00	5.836	1.2996	.1737	.0309	32.32
41.00	5.820	1.2920	.1727	.0308	32.51	
44.00	5.720	1.2449	1.2449	.1664	.0296	33.74
7 <sup>5</sup> / <sub>8</sub>	20.00	7.125	1.9813	.2649	.0472	21.20
	24.00	7.025	1.9235	.2571	.0458	21.83
	26.40	6.969	1.8916	.2529	.0450	22.20
	29.70	6.875	1.8385	.2458	.0438	22.85
	33.70	6.765	1.7773	.2376	.0423	23.63
	36.00	6.705	1.7443	.2332	.0415	24.08
	38.00	6.655	1.7170	.2295	.0409	24.46
	39.00	6.625	1.7008	.2274	.0405	24.69
	45.30	6.435	1.0090	1.0090	.2138	.0381

## Annular Volume Between Two Strings of Tubing and Casing

Tubing O.D. 1.315 in.

No allowance made for upsets and couplings.

Casing			Capacity			
O.D. in.	Weight lb/ft	I.D. in.	Gallons per Lineal Foot	Cubic Feet per Lineal Foot	Barrels per Lineal Foot	Lineal Feet per Barrel
4 <sup>1/2</sup>	9.50	4.090	.5414	.0724	.0129	77.58
	10.50	4.052	.5288	.0707	.0126	79.43
	11.60	4.000	.5117	.0684	.0122	82.08
	12.60	3.958	.4981	.0666	.0119	84.33
	13.50	3.920	.4858	.0649	.0116	86.45
	15.10	3.826	.4561	.0610	.0109	92.08
	16.60	3.754	.4339	.0580	.0103	96.80
	17.70	3.697	.4165	.0557	.0099	100.83
18.80	3.640	.3995	.0534	.0095	105.14	
4 <sup>3/4</sup>	16.00	4.082	.5387	.0720	.0128	77.96
5	11.50	4.560	.7073	.0945	.0168	59.38
	13.00	4.494	.6829	.0913	.0163	61.50
	15.00	4.408	.6517	.0871	.0155	64.45
	18.00	4.276	.6049	.0809	.0144	69.43
	20.30	4.184	.5731	.0766	.0136	73.28
	21.00	4.154	.5629	.0753	.0134	74.61
	23.20	4.044	.5261	.0703	.0125	79.83
5 <sup>1/2</sup>	13.00	5.044	.8969	.1199	.0214	46.83
	14.00	5.012	.8838	.1181	.0210	47.52
	15.00	4.974	.8683	.1161	.0207	48.37
	15.50	4.950	.8586	.1148	.0204	48.92
	17.00	4.892	.8353	.1117	.0199	50.28
	20.00	4.778	.7903	.1057	.0188	53.14
	23.00	4.670	.7487	.1001	.0178	56.10
	26.00	4.548	.7028	.0940	.0167	59.76
5 <sup>3/4</sup>	14.00	5.290	1.0006	.1338	.0238	41.97
	17.00	5.190	.9579	.1281	.0228	43.85
	19.50	5.090	.9159	.1224	.0218	45.85
	22.50	4.990	.8748	.1169	.0208	48.01
	25.20	4.890	.8345	.1116	.0189	50.33
6	15.00	5.524	1.1039	.1476	.0263	38.05
	16.00	5.500	1.0931	.1461	.0260	38.42
	17.00	5.450	1.0708	.1431	.0255	39.22
	18.00	5.424	1.0592	.1416	.0252	39.65
	20.00	5.352	1.0276	.1374	.0245	40.87
	23.00	5.240	.9792	.1309	.0233	42.89
	26.00	5.140	.9335	.1248	.0222	44.99



## Annular Volume Between Two Strings of Tubing and Casing

Tubing O.D. 1.315 in.

No allowance made for upsets and couplings.

C

Casing			Capacity			
O.D. in.	Weight lb/ft	I.D. in.	Gallons per Lineal Foot	Cubic Feet per Lineal Foot	Barrels per Lineal Foot	Lineal Feet per Barrel
6 <sup>5</sup> / <sub>8</sub>	13.00	6.255	1.4552	.1945	.0346	28.86
	17.00	6.135	1.3945	.1864	.0332	30.12
	20.00	6.049	1.3518	.1807	.0322	31.07
	22.00	5.989	1.3223	.1768	.0315	31.76
	24.00	5.921	1.2893	.1724	.0307	32.58
	26.00	5.855	1.2576	.1681	.0299	33.40
	28.00	5.791	1.2271	.1640	.0292	34.23
	29.00	5.761	1.2130	.1622	.0289	34.62
	32.00	5.675	1.1729	.1568	.0279	35.81
	34.00	5.595	1.1361	.1519	.0270	36.97
7	17.00	6.538	1.6029	.2143	.0382	26.20
	20.00	6.456	1.5594	.2085	.0371	26.93
	22.00	6.398	1.5290	.2044	.0364	27.47
	23.00	6.366	1.5124	.2022	.0360	27.77
	24.00	6.336	1.4968	.2001	.0356	28.06
	26.00	6.276	1.4659	.1960	.0349	28.65
	28.00	6.214	1.4343	.1917	.0342	29.28
	29.00	6.184	1.4192	.1897	.0338	29.60
	30.00	6.154	1.4041	.1877	.0334	29.91
	32.00	6.094	1.3741	.1837	.0327	30.57
	33.70	6.048	1.3513	.1806	.0322	31.08
	34.00	6.040	1.3473	.1801	.0321	31.17
	35.00	6.004	1.3297	.1777	.0317	31.59
	35.30	6.000	1.3277	.1775	.0316	31.63
	38.00	5.920	1.2888	.1723	.0307	32.59
40.00	5.836	1.2485	.1669	.0297	33.64	
41.00	5.820	1.2409	.1659	.0295	33.85	
44.00	5.720	1.1938	.1596	.0284	35.18	
7 <sup>5</sup> / <sub>8</sub>	20.00	7.125	1.9301	.2580	.0460	21.76
	24.00	7.025	1.8724	.2503	.0446	22.43
	26.40	6.969	1.8404	.2460	.0438	22.82
	29.70	6.875	1.7873	.2389	.0426	23.50
	33.70	6.765	1.7261	.2307	.0411	24.33
	36.00	6.705	1.6931	.2263	.0403	24.81
	38.00	6.655	1.6659	.2227	.0397	25.21
	39.00	6.625	1.6496	.2205	.0393	25.46
	45.30	6.435	1.5454	.2070	.0369	27.13

## Annular Volume Between Two Strings of Tubing and Casing

Tubing O.D. 1.660 in.

No allowance made for upsets and couplings.

Casing			Capacity			
O.D. in.	Weight lb/ft	I.D. in.	Gallons per Lineal Foot	Cubic Feet per Lineal Foot	Barrels per Lineal Foot	Lineal Feet per Barrel
4 <sup>1/2</sup>	9.50	4.090	.4576	.0612	.0109	91.77
	10.50	4.052	.4450	.0595	.0106	94.38
	11.60	4.000	.4279	.0672	.0102	98.14
	12.60	3.958	.4143	.0554	.0099	101.37
	13.50	3.920	.4021	.0538	.0096	104.45
	15.10	3.826	.3724	.0498	.0089	112.79
	16.60	3.754	.3501	.0468	.0083	119.96
	17.70	3.697	.3328	.0445	.0079	126.21
18.80	3.640	.3157	.0422	.0075	133.03	
4 <sup>3/4</sup>	16.00	4.082	.4550	.0608	.6108	92.31
5	11.50	4.560	.6235	.0834	.0148	67.36
	13.00	4.494	.5991	.0801	.0143	70.10
	15.00	4.408	.5679	.0759	.0135	73.96
	18.00	4.276	.5211	.0697	.0124	80.59
	20.30	4.184	.4894	.0654	.0117	85.82
	21.00	4.154	.4792	.0641	.0114	87.65
	23.20	4.044	.4424	.0591	.0105	94.94
5 <sup>1/2</sup>	13.00	5.044	.8132	.1087	.0194	51.65
	14.00	5.012	.8000	.1070	.0190	52.50
	15.00	4.974	.7846	.1049	.0187	53.53
	15.50	4.950	.7748	.1036	.0184	54.20
	17.00	4.892	.7516	.1005	.0179	55.88
	20.00	4.778	.7066	.0945	.0168	59.44
	23.00	4.670	.6649	.0889	.0158	63.16
	26.00	4.548	.6191	.0828	.0147	67.85
5 <sup>3/4</sup>	14.00	5.290	.9169	.1226	.0218	45.81
	17.00	5.190	.8741	.1169	.0208	48.05
	19.50	5.090	.8322	.1112	.0198	50.47
	22.50	4.990	.7911	.1058	.0188	53.09
	25.20	4.890	.7508	.1004	.0179	55.94
6	15.00	5.524	1.0201	.1364	.0243	41.17
	16.00	5.500	1.0093	.1349	.0240	41.61
	17.00	5.450	.9870	.1319	.0235	42.55
	18.00	5.424	.9755	.1304	.0232	43.06
	20.00	5.352	.9438	.1262	.0225	44.50
	23.00	5.240	.8954	.1197	.0213	46.91
	26.00	5.140	.8497	.1136	.0202	49.43



## Annular Volume Between Two Strings of Tubing and Casing

Tubing O.D. 1.660 in.

No allowance made for upsets and couplings.

C

Casing			Capacity			
O.D. in.	Weight lb/ft	I.D. in.	Gallons per Lineal Foot	Cubic Feet per Lineal Foot	Barrels per Lineal Foot	Lineal Feet per Barrel
$6\frac{5}{8}$	13.00	6.255	1.3714	.1833	.0327	30.62
	17.00	6.135	1.3108	.1752	.0312	32.04
	20.00	6.049	1.2680	.1695	.0302	33.12
	22.00	5.989	1.2386	.1656	.0295	33.91
	24.00	5.921	1.2055	.1612	.0287	34.84
	26.00	5.855	1.1738	.1569	.0279	35.78
	28.00	5.791	1.1434	.1528	.0272	36.73
	29.00	5.761	1.1293	.1510	.0269	37.19
	32.00	5.675	1.0891	.1456	.0259	38.56
	34.00	5.595	1.0523	.1407	.0251	39.91
7	17.00	6.538	1.5192	.2031	.0362	27.656
	20.00	6.456	1.4757	.1973	.0351	28.46
	22.00	6.398	1.4453	.1932	.0344	29.06
	23.00	6.366	1.4286	.1910	.0340	29.40
	24.00	6.336	1.4131	.1889	.0336	29.72
	26.00	6.276	1.3822	.1848	.0329	30.39
	28.00	6.214	1.3506	.1805	.0322	31.10
	29.00	6.184	1.3354	.1785	.0318	31.45
	30.00	6.154	1.3203	.1765	.0314	31.81
	32.00	6.094	1.2903	.1725	.0307	32.55
	33.70	6.048	1.2675	.1694	.0302	33.14
	34.00	6.040	1.2636	.1689	.0301	33.24
	35.00	6.004	1.2459	.1666	.0297	33.71
	35.30	6.000	1.2439	.1663	.0296	33.76
	38.00	5.920	1.2050	.1611	.0287	34.85
40.00	5.836	1.1647	.1557	.0277	36.06	
41.00	5.820	1.1571	.1547	.0276	36.30	
44.00	5.720	1.1101	.1484	.0264	37.84	
$7\frac{5}{8}$	20.00	7.125	1.8464	.2468	.0440	22.75
	24.00	7.025	1.7886	.2391	.0426	23.48
	26.40	6.969	1.7567	.2348	.0418	23.91
	29.70	6.875	1.7036	.2277	.0406	24.65
	33.70	6.765	1.6424	.2196	.0391	25.57
	36.00	6.705	1.6094	.2151	.0383	26.10
	38.00	6.655	1.5821	.2115	.0377	26.55
	39.00	6.625	1.5659	.2093	.0373	26.82
	45.30	6.435	1.4646	.1958	.0349	28.68

## Annular Volume Between Two Strings of Tubing and Casing

Tubing O.D. 1.900 in.

No allowance made for upsets and couplings.

Casing			Capacity			
O.D. in.	Weight lb/ft	I.D. in.	Gallons per Lineal Foot	Cubic Feet per Lineal Foot	Barrels per Lineal Foot	Lineal Feet per Barrel
5	11.50	4.560	.5538	.0740	.0132	75.84
	13.00	4.494	.5294	.0708	.0126	79.33
	15.00	4.408	.4982	.0666	.0119	84.31
	18.00	4.276	.4514	.0603	.0107	93.04
	20.30	4.184	.4197	.0561	.0100	100.08
	21.00	4.154	.4095	.0547	.0097	102.58
	23.20	4.044	.3727	.0498	.0089	112.70
5 <sup>1</sup> / <sub>2</sub>	13.00	5.044	.7435	.0994	.0177	56.49
	14.00	5.012	.7303	.0976	.0174	57.51
	15.00	4.974	.7148	.0956	.0170	58.75
	15.50	4.950	.7051	.0943	.0168	59.56
	17.00	4.892	.6818	.0911	.0162	61.60
	20.00	4.778	.6369	.0851	.0152	65.95
	23.00	4.670	.5952	.0796	.0142	70.56
5 <sup>3</sup> / <sub>4</sub>	14.00	5.290	.8472	.1133	.0202	49.58
	17.00	5.190	.8044	.1075	.0192	52.21
	19.50	5.090	.7625	.1019	.0182	55.08
	22.50	4.990	.7213	.0964	.0172	58.22
	25.20	4.890	.6812	.0910	.0162	61.67
6	15.00	5.524	.9504	.1271	.0226	44.19
	16.00	5.500	.9396	.1256	.0224	44.70
	17.00	5.450	.9173	.1226	.0218	45.79
	18.00	5.424	.9057	.1211	.0216	46.37
	20.00	5.352	.8741	.1168	.0208	48.05
	23.00	5.240	.8257	.1104	.0197	50.87
	26.00	5.140	.7800	.1043	.0186	53.85
6 <sup>5</sup> / <sub>8</sub>	13.00	6.255	1.3017	.1740	.0310	32.27
	17.00	6.135	1.2411	.1659	.0295	33.84
	20.00	6.049	1.1983	.1602	.0285	35.05
	22.00	5.989	1.1688	.1563	.0278	35.93
	24.00	5.921	1.1358	.1518	.0270	36.98
	26.00	5.855	1.1041	.1476	.0263	38.04
	28.00	5.791	1.0737	.1435	.0256	39.12
	29.00	5.761	1.0595	.1416	.0252	39.64
	32.00	5.675	1.0194	.1363	.0243	41.20
	34.00	5.595	.9826	.1314	.0234	42.74



## Annular Volume Between Two Strings of Tubing and Casing

Tubing O.D. 1.900 in.

No allowance made for upsets and couplings.

C

Casing			Capacity			
O.D. in.	Weight lb/ft	I.D. in.	Gallons per Lineal Foot	Cubic Feet per Lineal Foot	Barrels per Lineal Foot	Lineal Feet per Barrel
7	17.00	6.538	1.4494	.1938	.0345	28.98
	20.00	6.456	1.4060	.1879	.0335	29.87
	22.00	6.398	1.3755	.1839	.0328	30.53
	23.00	6.366	1.3589	.1817	.0324	30.91
	24.00	6.336	1.3433	.1796	.0320	31.27
	26.00	6.276	1.3125	.1755	.0312	32.00
	28.00	6.214	1.2809	.1712	.0305	32.79
	29.00	6.184	1.2657	.1692	.0301	33.18
	30.00	6.154	1.2506	.1672	.0298	33.58
	32.00	6.094	1.2206	.1632	.0291	34.41
	33.70	6.048	1.1978	.1601	.0285	35.06
	34.00	6.040	1.1939	.1596	.0284	35.18
	35.00	6.004	1.1762	.1572	.0280	35.71
	35.30	6.000	1.1742	.1570	.0280	35.77
	38.00	5.920	1.1353	.1518	.0270	36.99
	40.00	5.836	1.0950	.1464	.0261	38.36
	41.00	5.820	1.0874	.1454	.0259	38.62
44.00	5.720	1.0403	1.0403	.1391	.0248	40.37
7 <sup>5</sup> / <sub>8</sub>	20.00	7.125	1.7767	.2375	.0423	23.64
	24.00	7.025	1.7189	.2298	.0409	24.43
	26.40	6.969	1.6870	.2255	.0402	24.90
	29.70	6.875	1.6339	.2184	.0389	25.71
	33.70	6.765	1.5726	.2102	.0374	26.71
	36.00	6.705	1.5397	.2058	.0367	27.28
	38.00	6.655	1.5125	.2022	.0360	27.77
	39.00	6.625	1.4962	.2000	.356	28.07
45.30	6.435	1.3949	.1865	.0332	30.11	
7 <sup>3</sup> / <sub>4</sub>	46.10	6.560	1.4612	.1953	.0348	28.74
8 <sup>5</sup> / <sub>8</sub>	24.00	8.097	2.3803	.3182	.0567	17.64
	28.00	8.017	2.3277	.3112	.0554	18.04
	32.00	7.921	2.2653	.3028	.0539	18.54
	36.00	7.825	2.2036	.2946	.0525	19.06
	38.00	7.775	2.1718	.2903	.0517	19.34
	40.00	7.725	2.1402	.2861	.0510	19.62
	43.00	7.651	2.0937	.2799	.0499	20.06
	44.00	7.625	2.0775	.2777	.0495	20.22
	48.00	7.537	2.0231	.2705	.0482	20.76
	49.00	7.511	2.0071	2.0071	.2683	.0478

## Annular Volume Between Two Strings of Tubing and Casing

Tubing O.D. 1.900 in.

No allowance made for upsets and couplings.

Casing			Capacity			
O.D. in.	Weight lb/ft	I.D. in.	Gallons per Lineal Foot	Cubic Feet per Lineal Foot	Barrels per Lineal Foot	Lineal Feet per Barrel
9 <sup>5</sup> / <sub>8</sub>	29.30	9.063	3.0566	.4086	.0728	13.74
	32.30	9.001	3.0109	.4025	.0717	13.95
	36.00	8.921	2.9524	.3947	.0703	14.23
	38.00	8.885	2.9263	.3912	.0697	14.35
	40.00	8.835	2.8901	.3864	.0688	14.53
	42.00	8.799	2.8643	.3829	.0682	14.66
	43.50	8.755	2.8327	.3787	.0674	14.83
	47.00	8.681	2.7801	.3716	.0662	15.11
	53.50	8.535	2.6775	.3579	.0638	15.69
	58.40	8.435	2.6083	.3487	.0621	16.10
	61.10	8.375	2.5672	.3432	.0611	16.36
	71.80	8.125	2.3989	.3207	.0571	17.51





## Annular Volume Between Two Strings of Tubing and Casing

Tubing O.D. 2.063 in.

No allowance made for upsets and couplings.

C

Casing			Capacity			
O.D. in.	Weight lb/ft	I.D. in.	Gallons per Lineal Foot	Cubic Feet per Lineal Foot	Barrels per Lineal Foot	Lineal Feet per Barrel
5 <sup>1/2</sup>	13.00	5.044	.6907	.0923	.0164	60.80
	14.00	5.012	.6776	.0906	.0106	61.98
	15.00	4.974	.6621	.0885	.0158	63.43
	15.50	4.950	.6524	.0872	.0155	64.38
	17.00	4.892	.6291	.0841	.0150	66.76
	20.00	4.778	.5841	.0871	.0139	71.90
	23.00	4.670	.5425	.0725	.0129	77.42
	26.00	4.548	.4970	.0664	.0118	84.51
5 <sup>3/4</sup>	14.00	5.290	.7945	.1062	.0189	52.87
	17.00	5.190	.7517	.1005	.0179	55.87
	19.50	5.090	.7098	.0949	.0169	59.17
	22.50	4.990	.6686	.0894	.0159	62.81
	25.20	4.890	.6283	.0840	.0150	66.84
6	15.00	5.524	.8977	.1200	.0214	46.79
	16.00	5.500	.8869	.1186	.0211	47.36
	17.00	5.450	.8646	.1156	.0206	48.58
	18.00	5.424	.8530	.1140	.0203	49.24
	20.00	5.352	.8214	.1098	.0196	51.13
	23.00	5.240	.7730	.1033	.0184	54.34
	26.00	5.140	.7273	.0972	.0173	57.75
6 <sup>5/8</sup>	13.00	6.255	1.2490	.1670	.0297	33.63
	17.00	6.135	1.1884	.1589	.0283	35.34
	20.00	6.049	1.1456	.1531	.0273	36.66
	22.00	5.989	1.1161	.1492	.0266	37.63
	24.00	5.921	1.0831	.1448	.0258	38.78
	26.00	5.855	1.0514	.1405	.0250	39.95
	28.00	5.791	1.0210	.1365	.0243	41.14
	29.00	5.761	1.0068	.1346	.0240	41.72
	32.00	5.675	.9667	.1292	.0230	43.45
	34.00	5.595	.9299	.1243	.0221	45.17
	7	17.00	6.538	1.3967	.1867	.0333
20.00		6.456	1.3533	.1809	.0322	31.04
22.00		6.398	1.3228	.1768	.0315	31.75
23.00		6.366	1.3062	.1746	.0311	32.16
24.00		6.336	1.2906	.1725	.0307	32.54
26.00		6.276	1.2597	.1684	.0300	33.34
28.00		6.214	1.2282	.1642	.0292	34.20

## Annular Volume Between Two Strings of Tubing and Casing

Tubing O.D. 2.063 in.

No allowance made for upsets and couplings.

Casing			Capacity			
O.D. in.	Weight lb/ft	I.D. in.	Gallons per Lineal Foot	Cubic Feet per Lineal Foot	Barrels per Lineal Foot	Lineal Feet per Barrel
7	29.00	6.184	1.2130	.1622	.0289	34.63
	30.00	6.154	1.1979	.1601	.0285	35.06
	32.00	6.094	1.1679	.1561	.0278	35.96
	33.70	6.048	1.1451	.1531	.0273	36.68
	34.00	6.040	1.1412	.1526	.0272	36.80
	35.00	6.004	1.1235	.1502	.0267	37.38
	35.30	6.000	1.1215	.1499	.0267	37.45
	38.00	5.920	1.0826	.1447	.0258	38.80
	40.00	5.836	1.0423	.1393	.0248	40.29
	41.00	5.820	1.0347	.1383	.0246	40.59
	44.00	5.720	.9876	.1320	.0235	42.53
7 <sup>5</sup> / <sub>8</sub>	20.00	7.125	1.7239	.2305	.0410	24.36
	24.00	7.025	1.6662	.2227	.0297	25.21
	26.40	6.969	1.5342	.2185	.0389	25.70
	29.70	6.875	1.5811	.2114	.0376	26.56
	33.70	6.765	1.5199	.2032	.0362	27.63
	36.00	6.705	1.4870	.1988	.0354	28.25
	38.00	6.655	1.4597	.1951	.0348	28.77
	39.00	6.625	1.4434	.1930	.0344	29.10
	45.30	6.435	1.3422	.1794	.0320	31.29
7 <sup>3</sup> / <sub>4</sub>	46.10	6.560	1.4085	.1883	.0335	29.82
8 <sup>5</sup> / <sub>8</sub>	24.00	8.097	2.3276	.3112	.0554	18.04
	28.00	8.017	2.2750	.3041	.0542	18.46
	32.00	7.921	2.2126	.2958	.0527	18.98
	36.00	7.825	2.1509	.2875	.0512	19.53
	38.00	7.775	2.1191	.2833	.0505	19.82
	40.00	7.725	2.0875	.2791	.0497	20.12
	43.00	7.651	2.0411	.2728	.0486	20.58
	44.00	7.625	2.0248	.2707	.0482	20.74
	48.00	7.537	1.9704	.2634	.0469	21.32
	49.00	7.511	1.9544	.2613	.0465	21.49



## Annular Volume Between Two Strings of Tubing and Casing

Tubing O.D. 2.063 in.

No allowance made for upsets and couplings.

C

Casing			Capacity			
O.D. in.	Weight lb/ft	I.D. in.	Gallons per Lineal Foot	Cubic Feet per Lineal Foot	Barrels per Lineal Foot	Lineal Feet per Barrel
9 <sup>5</sup> / <sub>8</sub>	29.30	9.063	3.0039	.4016	.0715	13.98
	32.30	9.001	2.9582	.3955	.0704	14.20
	36.00	8.921	2.8997	.3876	.0690	14.48
	38.00	8.885	2.8678	.3834	.0683	14.65
	40.00	8.835	2.8374	.3793	.0676	14.80
	42.00	8.799	2.8115	.3758	.0669	14.94
	43.50	8.755	2.7800	.3716	.0662	15.11
	47.00	8.681	2.7274	.3646	.0649	15.40
53.50	8.535	2.6248	.3509	.0625	16.00	
13 <sup>3</sup> / <sub>8</sub>	48.00	12.715	6.2489	.8354	.1488	6.72
	54.50	12.615	6.1455	.8215	.1463	6.83
	61.00	12.515	6.0430	.8078	.1439	6.95
	68.00	12.415	5.9413	.7942	.1415	7.07
	72.00	12.347	5.8726	.7851	.1398	7.15
	83.00	12.175	5.7005	.7620	.1357	7.37

## Annular Volume Between Two Strings of Tubing and Casing

Tubing O.D. 2.375 in.

No allowance made for upsets and couplings.

Casing			Capacity			
O.D. in.	Weight lb/ft	I.D. in.	Gallons per Lineal Foot	Cubic Feet per Lineal Foot	Barrels per Lineal Foot	Lineal Feet per Barrel
6	15.00	5.524	.7847	.1049	.0187	53.52
	16.00	5.500	.7739	.1035	.0184	54.27
	17.00	5.450	.7516	.1005	.0179	55.88
	18.00	5.424	.7401	.0989	.0176	55.88
	20.00	5.352	.7084	.0947	.0169	59.29
	23.00	5.240	.6600	.0882	.0157	63.64
	26.00	5.140	.6243	.0821	.0146	68.37
6 <sup>5</sup> / <sub>8</sub>	13.00	6.255	1.1360	.1519	.0270	36.97
	17.00	6.135	1.0754	.1438	.0256	39.06
	20.00	6.049	1.0326	.1380	.0246	40.67
	22.00	5.989	1.0031	.1341	.0239	41.87
	24.00	5.921	.9701	.1297	.0231	43.29
	26.00	5.855	.9384	.1254	.0223	44.76
	28.00	5.791	.9080	.1214	.0216	46.26
	29.00	5.761	.8938	.1195	.0213	46.99
	32.00	5.675	.8537	.1141	.0203	49.20
	34.00	5.595	.8169	.1092	.0195	51.41
7	17.00	6.538	1.2837	.1716	.0306	32.72
	20.00	6.456	1.2403	.1658	.0295	33.86
	22.00	6.398	1.2098	.1617	.0288	34.72
	23.00	6.366	1.1932	.1595	.0284	35.20
	24.00	6.336	1.1776	.1574	.0280	35.66
	26.00	6.276	1.1468	.1533	.0273	36.62
	28.00	6.214	1.1152	.1491	.0266	37.66
	29.00	6.184	1.1000	.1470	.0262	38.18
	30.00	6.154	1.0849	.1450	.0258	38.71
	32.00	6.094	1.0549	.1410	.0251	39.81
	33.70	6.048	1.0321	.1380	.0246	40.69
	34.00	6.040	1.0282	.1374	.0245	40.85
	35.00	6.004	1.0105	.1351	.0241	41.56
	35.30	6.000	1.0085	.1348	.0240	41.65
	38.00	5.920	.9696	.1296	.0231	43.32
40.00	5.836	.9293	.1242	.0221	45.19	
41.00	5.820	.9217	.1232	.0219	45.57	
44.00	5.720	.8746	.1169	.0208	48.02	



## Annular Volume Between Two Strings of Tubing and Casing

Tubing O.D. 2.375 in.

No allowance made for upsets and couplings.

C

Casing			Capacity			
O.D. in.	Weight lb/ft	I.D. in.	Gallons per Lineal Foot	Cubic Feet per Lineal Foot	Barrels per Lineal Foot	Lineal Feet per Barrel
$7\frac{5}{8}$	20.00	7.125	1.6110	.2154	.0384	26.07
	24.00	7.025	1.5532	.2076	.0370	27.04
	26.40	6.969	1.5213	.2034	.0362	27.61
	29.70	6.875	1.4682	.1963	.0350	28.61
	33.70	6.765	1.2069	.1881	.0335	29.85
	36.00	6.705	1.3740	.1837	.0327	30.57
	38.00	6.655	1.3467	.1800	.0321	31.19
	39.00	6.625	1.3305	.1779	.0317	31.57
	45.30	6.435	1.2292	.1643	.0293	34.17
$7\frac{3}{4}$	46.10	6.560	1.2955	.1732	.0308	32.42
8	26.00	7.386	1.7655	.2360	.0420	23.79
$8\frac{1}{8}$	28.00	7.485	1.8255	.2440	.0435	23.01
	32.00	7.385	1.7649	.2359	.0420	23.80
	35.50	7.285	1.7050	.2279	.0406	24.63
	39.50	7.185	1.6460	.2200	.0392	25.52
$8\frac{5}{8}$	24.00	8.097	2.2146	.2961	.0527	18.96
	28.00	8.017	2.1620	.2890	.0515	19.43
	32.00	7.921	2.0996	.2807	.0500	20.00
	36.00	7.825	2.0379	.2724	.0485	20.61
	38.00	7.775	2.0061	.2682	.0478	20.94
	40.00	7.725	1.9745	.2540	.0470	21.27
	43.00	7.651	1.9281	.2577	.0459	21.78
	44.00	7.625	1.9119	.2556	.0455	21.97
	48.00	7.537	1.8574	.2483	.0422	22.61
	49.00	7.511	1.8415	.2462	.0438	22.81
$8\frac{3}{4}$	49.70	7.636	1.9187	.2565	.0457	21.89
9	34.00	8.290	2.3437	.3133	.0558	17.92
	38.00	8.196	2.2804	.3048	.0543	18.42
	40.00	8.150	2.2498	.3007	.0536	18.67
	45.00	8.032	2.1719	.2903	.0517	19.34
	50.20	7.910	2.0925	.2797	.0498	20.07
	55.00	7.812	2.0296	.2713	.0483	20.69

## Annular Volume Between Two Strings of Tubing and Casing

Tubing O.D. 2.375 in.

No allowance made for upsets and couplings.

Casing			Capacity			
O.D. in.	Weight lb/ft	I.D. in.	Gallons per Lineal Foot	Cubic Feet per Lineal Foot	Barrels per Lineal Foot	Lineal Feet per Barrel
9 <sup>5</sup> / <sub>8</sub>	29.30	9.063	2.8909	.3865	.0688	14.53
	32.30	9.001	2.8453	.3804	.0677	14.76
	36.00	8.921	2.7868	.3725	.0664	15.07
	38.00	8.885	2.7548	.3683	.0656	15.25
	40.00	8.835	2.7245	.3642	.0649	15.42
	42.00	8.799	2.6986	.3607	.0643	15.56
	43.50	8.755	2.6670	.3565	.0635	15.75
	47.00	8.681	2.6144	.3495	.0622	16.06
	53.50	8.535	2.1118	.3358	.0598	16.72
	58.40	8.435	2.4426	.3265	.0582	17.19
	61.10	8.375	2.4015	.3210	.0572	17.49
71.80	8.125	2.2332	.2985	.0532	18.81	
9 <sup>3</sup> / <sub>4</sub>	59.20	8.560	2.5293	.3381	.0602	16.61
9 <sup>7</sup> / <sub>8</sub>	62.80	8.625	2.5749	.3442	.0613	16.31
10	33.00	9.384	3.1325	.4188	.0746	13.41
	41.50	9.200	2.9930	.4001	.0713	14.03
	45.50	9.120	2.9332	.3921	.0698	14.32
	50.50	9.016	2.8563	.3818	.0680	14.71
	55.50	8.908	2.7773	.3713	.0661	15.12
61.20	8.790	2.6521	.3599	.0641	15.60	
10 <sup>3</sup> / <sub>4</sub>	32.75	10.192	3.7779	.5050	.0899	11.12
	35.75	10.136	3.7314	.4988	.0888	11.26
	40.50	10.050	3.6606	.4894	.0872	11.47
	45.50	9.950	3.5790	.4784	.0852	11.74
	48.00	9.902	3.5401	.4732	.0843	11.86
	51.00	9.850	3.4982	.4676	.0833	12.01
	54.00	9.784	3.4454	.4606	.0820	12.19
	55.50	9.760	3.4262	.4580	.0816	12.26
	60.70	9.660	3.3470	.4474	.0797	12.55
65.70	9.560	3.2686	.4369	.0778	12.85	
11 <sup>3</sup> / <sub>4</sub>	38.00	11.150	4.6121	.6165	.1098	9.11
	42.00	11.084	4.5522	.6085	.1084	9.23
	47.00	11.000	4.4765	.5984	.1066	9.38
	54.00	10.880	4.3694	.5841	.1040	9.61
	60.00	10.772	4.2740	.5713	1.750	.1018



## Annular Volume Between Two Strings of Tubing and Casing

Tubing O.D. 2.375 in.

No allowance made for upsets and couplings.

C

Casing			Capacity			
O.D. in.	Weight lb/ft	I.D. in.	Gallons per Lineal Foot	Cubic Feet per Lineal Foot	Barrels per Lineal Foot	Lineal Feet per Barrel
13 <sup>3</sup> / <sub>8</sub>	48.00	12.715	6.1359	.8203	.1461	6.85
	54.50	12.615	6.0326	.8064	.1436	6.96
	61.00	12.515	5.9300	.7927	.1412	7.08
	68.00	12.415	5.8283	.7791	.1388	7.21
	72.00	12.347	5.7596	.7699	.1371	7.29
	77.00	12.275	5.6873	.7603	.1354	7.38
	83.00	12.175	5.5875	.7569	.1330	7.52
16	55.00	15.375	9.1844	1.2279	.2187	4.57
	65.00	15.250	9.0283	1.2069	.2150	4.65
	70.00	15.198	8.9637	1.1983	.2134	4.69
	75.00	15.125	8.8733	1.1862	.2113	4.73
	84.00	15.010	8.7319	1.1673	.2079	4.81

## Annular Volume Between Two Strings of Tubing and Casing

Tubing O.D. 2.875 in.

No allowance made for upsets and couplings.

Casing			Capacity			
O.D. in.	Weight lb/ft	I.D. in.	Gallons per Lineal Foot	Cubic Feet per Lineal Foot	Barrels per Lineal Foot	Lineal Feet per Barrel
7	17.00	6.538	1.0695	.1430	.0255	39.27
	20.00	6.456	1.0261	.1372	.0244	40.93
	22.00	6.398	.9956	.1331	.0237	42.18
	23.00	6.366	.9790	.1309	.0233	42.90
	24.00	6.336	.9634	.1288	.0229	43.59
	26.00	6.276	.9326	.1247	.0222	45.04
	28.00	6.214	.9010	.1204	.0215	46.62
	29.00	6.184	.8858	.1184	.0211	47.42
	30.00	6.154	.8707	.1164	.0207	48.24
	32.00	6.094	.8407	.1124	.0200	49.96
	33.70	6.048	.8179	.1093	.0195	51.35
	34.00	6.040	.8140	.1088	.0194	51.60
	35.00	6.004	.7963	.1064	.0190	52.75
	35.30	6.000	.7943	.1062	.0189	52.88
	38.00	5.920	7.554	.1010	.0180	55.60
	40.00	5.836	.7151	.0956	.0170	58.73
41.00	5.820	.7075	.0946	.0168	59.36	
44.00	5.720	.6604	.0883	.0157	63.59	
7 <sup>5</sup> / <sub>8</sub>	20.00	7.125	1.3968	.1867	.0333	30.07
	24.00	7.025	1.3390	.1790	.0319	31.37
	26.40	6.969	1.3071	.1747	.0311	32.13
	29.70	6.875	1.2540	.1676	.0299	33.49
	33.70	6.765	1.1927	.1594	.0284	35.21
	36.00	6.705	1.1598	.1550	.0276	36.21
	38.00	6.655	1.1325	.1514	.0270	37.09
	39.00	6.625	1.1163	.1492	.0266	37.63
45.30	6.435	1.0150	.1357	.0242	41.38	
7 <sup>3</sup> / <sub>4</sub>	46.10	6.560	1.0813	.1445	.0257	38.84





## Annular Volume Between Two Strings of Tubing and Casing

Tubing O.D. 2.875 in.

No allowance made for upsets and couplings.

C

Casing			Capacity			
O.D. in.	Weight lb/ft	I.D. in.	Gallons per Lineal Foot	Cubic Feet per Lineal Foot	Barrels per Lineal Foot	Lineal Feet per Barrel
8	26.00	7.386	1.5513	.2074	.0369	27.07
8 <sup>1</sup> / <sub>8</sub>	28.00	7.485	1.6114	.2154	.0384	26.07
	32.00	7.385	1.5507	.2073	.0369	27.08
	35.50	7.285	1.4908	.1993	.0355	28.17
	39.50	7.185	1.4318	.1914	.0341	29.33
8 <sup>5</sup> / <sub>8</sub>	24.00	8.097	2.0004	.2674	.0476	21.00
	28.00	8.017	1.9478	.2604	.0464	21.56
	32.00	7.921	1.8854	.2520	.0449	22.28
	36.00	7.825	1.8237	.2438	.0434	23.03
	38.00	7.775	1.7919	.2395	.0427	23.44
	40.00	7.725	1.7603	.2353	.0419	23.86
	43.00	7.651	1.7139	.2291	.0408	24.51
	44.00	7.625	1.6977	.2269	.0404	24.74
	48.00	7.537	1.6432	.2197	.0391	25.56
49.00	7.511	1.6273	.2175	.0387	25.81	
8 <sup>3</sup> / <sub>4</sub>	49.70	7.636	1.7045	.2279	.0406	24.64
9	34.00	8.290	2.1295	.2847	.0507	19.72
	38.00	8.196	2.0662	.2762	.0492	20.33
	40.00	8.150	2.0356	.2721	.0485	20.63
	45.00	8.032	1.9577	.2617	.0466	21.45
	50.20	7.910	1.8783	.2511	.0447	22.36
55.00	7.812	1.8154	.2427	.0432	23.13	
9 <sup>5</sup> / <sub>8</sub>	29.30	9.063	2.6767	.3578	.0637	15.69
	32.30	9.001	2.6311	.3517	.0626	15.96
	36.00	8.921	2.5726	.3439	.0613	16.33
	38.00	8.885	2.5406	.3396	.0605	16.53
	40.00	8.835	2.5103	.3356	.0598	16.73
	42.00	8.799	2.4844	.3321	.0592	16.91
	43.50	8.755	2.4528	.3279	.0584	17.12
	47.00	8.681	2.4002	.3209	.0571	17.50
	53.50	8.535	2.2976	.3072	.0547	18.28
	58.40	8.435	2.2284	.2979	.0531	18.85
	61.10	8.375	2.1873	.2924	.0521	19.20
	71.80	8.125	2.0190	.2699	.0841	20.80
9 <sup>3</sup> / <sub>4</sub>	59.20	8.560	2.3151	.3095	.0551	18.14
9 <sup>7</sup> / <sub>8</sub>	62.80	8.625	2.3607	.3156	.0562	17.79

## Annular Volume Between Two Strings of Tubing and Casing

Tubing O.D. 2.875 in.

No allowance made for upsets and couplings.

Casing			Capacity			
O.D. in.	Weight lb/ft	I.D. in.	Gallons per Lineal Foot	Cubic Feet per Lineal Foot	Barrels per Lineal Foot	Lineal Feet per Barrel
10	33.00	9.384	2.9183	.3901	.0695	14.39
	41.50	9.200	2.7788	.3715	.0662	15.11
	45.50	9.120	2.7190	.3635	.0647	15.45
	50.50	9.016	2.6421	.3132	.0629	15.90
	55.50	8.908	2.5631	.3426	.0610	16.39
	61.20	8.790	2.4779	.3312	.0590	16.95
10 <sup>3/4</sup>	32.75	10.192	3.5637	.4764	.0848	11.79
	35.75	10.136	3.5172	.4702	.0837	11.94
	40.50	10.050	3.4464	.4607	.0821	12.19
	45.50	9.950	3.3648	.4498	.0801	12.48
	48.00	9.902	3.3259	.4446	.0792	12.63
	51.00	9.850	3.2840	.4390	.0782	12.79
	54.00	9.784	3.2312	.4319	.0769	13.00
	55.50	9.760	3.2120	.4294	.0765	13.08
	60.70	9.660	3.1328	.4188	.0746	13.41
	65.70	9.560	3.0544	.4083	.0727	13.75
	71.10	9.450	2.9691	.3969	.0707	14.15
	76.00	9.350	2.8924	.3867	.0689	14.52
81.00	9.250	2.8165	.3765	.0671	14.91	
11 <sup>3/4</sup>	38.00	11.150	4.3979	.5879	.1047	9.55
	42.00	11.084	4.3380	.5799	.1033	9.68
	47.00	11.000	4.2623	.5698	.1015	9.85
	54.00	10.880	4.1552	.5555	.0989	10.11
	60.00	10.772	4.0598	.5427	.0967	10.35
	65.00	10.682	3.9810	.5322	.0948	10.55
71.00	10.586	3.8974	.5210	.0928	10.78	
13 <sup>3/8</sup>	48.00	12.715	5.9217	.7916	.1410	7.09
	54.50	12.615	5.8184	.7778	.1385	7.22
	61.00	12.515	5.7158	.7641	.1361	7.35
	68.00	12.415	5.6141	.7505	.1337	7.48
	72.00	12.347	5.5454	.7413	.1320	7.57
	83.00	12.175	5.3733	.7183	.1279	7.82
16	55.00	15.375	8.9715	1.1993	.2136	4.68
	65.00	15.250	8.8141	1.1783	.2099	4.77
	70.00	15.198	8.7495	1.1696	.2083	4.80
	75.00	15.125	8.6579	1.1574	.2061	4.85
	84.00	15.010	8.5177	1.1387	.2028	4.93



## Annular Volume Between Two Strings of Tubing and Casing

Tubing O.D. 3.500 in.

No allowance made for upsets and couplings.

C

Casing			Capacity			
O.D. in.	Weight lb/ft	I.D. in.	Gallons per Lineal Foot	Cubic Feet per Lineal Foot	Barrels per Lineal Foot	Lineal Feet per Barrel
8 <sup>5/8</sup>	24.00	8.097	1.6753	.2240	.0399	25.07
	28.00	8.017	1.6227	.2169	.0386	25.88
	32.00	7.921	1.5603	.2086	.0371	26.92
	36.00	7.825	1.4986	.2003	.0357	28.03
	38.00	7.775	1.4668	.1961	.0349	28.63
	40.00	7.725	1.4352	.1919	.0342	29.27
	43.00	7.651	1.3887	.1856	.0331	30.24
	44.00	7.625	1.3725	.1835	.0327	30.60
	48.00	7.537	1.3181	.1762	.0314	31.86
	49.00	7.511	1.3021	.1741	.0310	32.25
8 <sup>3/4</sup>	49.70	7.636	1.3794	.1844	.0328	30.45
9	34.00	8.290	1.8043	.2412	.0430	23.28
	38.00	8.196	1.7411	.2328	.0415	24.12
	40.00	8.150	1.7104	.2287	.0407	24.56
	45.00	8.032	1.6325	.2182	.0389	25.73
	50.20	7.910	1.5532	.2076	.0370	27.04
	55.00	7.812	1.4903	.1992	.0355	28.18
9 <sup>5/8</sup>	29.30	9.063	2.3516	.3144	.0560	17.86
	32.30	9.001	2.3059	.3083	.0549	18.21
	36.00	8.921	2.2474	.3004	.0535	18.69
	38.00	8.885	2.2155	.2962	.0527	18.96
	40.00	8.835	2.1851	.2921	.0520	19.22
	42.00	8.799	2.1592	.2886	.0514	19.45
	43.50	8.755	2.1277	.2844	.0507	19.74
	47.00	8.681	2.0751	.2774	.0494	20.24
	53.50	8.535	1.9725	.2637	.0470	21.29
	58.40	8.435	1.9033	.2544	.0453	22.07
	61.10	8.375	1.8621	.2489	.0443	22.56
	71.80	8.125	1.6938	.2264	.0403	24.80
9 <sup>3/4</sup>	59.20	8.560	1.9900	.2660	.0474	21.11
9 <sup>7/8</sup>	62.80	8.625	2.0355	.2721	.0485	20.63

## Annular Volume Between Two Strings of Tubing and Casing

Tubing O.D. 3.500 in.

No allowance made for upsets and couplings.

Casing			Capacity			
O.D. in.	Weight lb/ft	I.D. in.	Gallons per Lineal Foot	Cubic Feet per Lineal Foot	Barrels per Lineal Foot	Lineal Feet per Barrel
10	33.00	9.384	2.5932	.3467	.0617	16.20
	41.50	9.200	2.4537	.3280	.0584	17.12
	45.50	9.120	2.3989	.3200	.0570	17.54
	50.50	9.016	2.3170	.3907	.0552	18.13
	55.50	8.908	2.380	.2992	.0533	18.77
	61.20	8.790	2.153	.2878	.0513	19.51
10 <sup>3</sup> / <sub>4</sub>	32.75	10.192	3.2386	.4329	.0771	12.97
	35.75	10.136	3.1921	.4267	.0760	13.13
	40.50	10.050	3.1213	.4173	.0743	13.46
	45.50	9.950	3.0397	.4063	.0724	13.82
	48.00	9.902	3.0008	.4012	.0714	14.00
	51.00	9.850	2.9589	.3955	.0705	14.19
	54.00	9.784	2.9060	.3885	.0692	14.45
	55.50	9.760	2.8869	.3859	.0687	14.55
	60.70	9.660	2.8077	.3753	.0668	14.96
	65.70	9.560	2.7293	.3648	.0650	15.39
	71.10	9.450	2.6439	.3534	.0630	15.89
	76.00	9.350	2.5672	.3432	.0611	16.36
81.00	9.250	2.4913	.3330	.0593	16.86	
11 <sup>3</sup> / <sub>4</sub>	38.00	11.150	4.0727	.5444	.0970	10.31
	42.00	11.084	4.0129	.5364	.0955	10.47
	47.00	11.000	3.9372	.5263	.0937	10.67
	54.00	10.880	3.8301	.5120	.0912	10.97
	60.00	10.772	3.7347	.4993	.0889	11.25
	65.00	10.682	3.6559	.4887	.0890	11.49
	71.00	10.586	3.5726	.4776	.0851	11.76
11 <sup>7</sup> / <sub>8</sub>	71.80	10.711	3.6812	.4921	.0876	11.41
12	40.00	1.384	4.2879	.5732	.1021	9.80
12 <sup>3</sup> / <sub>4</sub>	43.00	12.130	5.0036	.6689	.1191	8.39
	53.00	11.970	4.8462	.6478	.1154	8.67



## Annular Volume Between Two Strings of Tubing and Casing

Tubing O.D. 3.500 in.

No allowance made for upsets and couplings.

C

Casing			Capacity			
O.D. in.	Weight lb/ft	I.D. in.	Gallons per Lineal Foot	Cubic Feet per Lineal Foot	Barrels per Lineal Foot	Lineal Feet per Barrel
13	40.00	12.438	5.3123	.7102	.1265	7.91
	45.00	12.360	5.2334	.6996	.1246	8.03
	50.00	12.282	5.1550	.6891	.1227	8.15
	54.00	12.220	5.0930	.6808	.1213	8.25
	48.00	12.715	5.5966	.7482	.1333	7.50
	54.50	12.615	5.4932	.7343	.1308	7.65
13 <sup>3/8</sup>	61.00	12.515	5.3907	.7206	.1283	7.79
	68.00	12.415	5.2890	.7070	.1259	7.94
	72.00	12.347	5.2203	.6979	.1243	8.05
	77.00	12.275	5.1480	.6882	.1226	8.16
	83.00	12.175	5.0482	.6748	.1202	8.32
	85.00	12.159	5.0323	.6727	.1198	8.35
	92.00	12.031	4.9060	.6558	.1168	8.56
	98.00	11.937	4.8141	.6435	.1146	8.72
16	55.00	15.375	8.6464	1.1559	.2059	4.86
	65.00	15.250	8.4889	1.1348	.2021	4.95
	70.00	15.198	8.4243	1.1262	.2006	4.99
	75.00	15.125	8.3328	1.1139	.1984	5.04
	84.00	15.010	8.1926	1.0952	.1951	5.13
	109.00	14.688	7.8025	1.0430	.1858	5.38
20	90.00	19.166	13.9877	1.8699	.3330	3.00
	94.00	19.124	13.9220	1.8611	.3315	3.02
	106.50	19.000	13.729	1.8353	.3269	3.06
	133.00	18.730	13.3135	1.7798	.3170	3.15

## Annular Volume Between Three Strings of Tubing and Casing

Tubing O.D. 1.050 in.

No allowance made for upsets and couplings.

Casing			Capacity			
O.D. in.	Weight lb/ft	I.D. in.	Gallons per Lineal Foot	Cubic Feet per Lineal Foot	Barrels per Lineal Foot	Lineal Feet per Barrel
<b>4<sup>1</sup>/<sub>2</sub></b>	9.50	4.090	.5476	.0732	.0130	76.70
	10.50	4.052	.5349	.0715	.0127	78.51
	11.60	4.000	.5179	.0692	.0123	81.10
	12.60	3.958	.5042	.0674	.0120	83.30
	114.3	3.920	.4920	.0658	.0117	85.37
	15.10	3.826	.4623	.0618	.0110	90.85
	16.60	3.754	.4400	.0588	.0105	95.45
	17.70	3.697	.4227	.0565	.0101	99.36
	18.80	3.640	.4056	.0542	.0097	103.54
4 <sup>3</sup> / <sub>4</sub>	16.00	4.082	.5449	.0728	.0230	77.08
<b>5</b>	11.50	4.560	.7134	.0954	.0170	58.87
	13.00	4.494	.6891	.0921	.0164	60.95
	15.00	4.408	.6578	.0879	.0157	63.85
	18.00	4.276	.6110	.0817	.0145	68.73
	20.30	4.184	.5793	.0774	.0138	72.50
	21.00	4.154	.5691	.0761	.0135	73.80
	23.20	4.044	.5323	.0712	.0127	78.90
<b>5<sup>1</sup>/<sub>2</sub></b>	13.00	5.044	.9031	.1207	.0215	46.51
	14.00	5.012	.8900	.1190	.0212	47.19
	15.00	4.974	.8745	.1169	.0208	48.03
	15.50	4.950	.8648	.1156	.0206	48.57
	17.00	4.892	.8415	.1125	.0200	49.91
	20.00	4.778	.7965	.1065	.0190	52.73
	23.00	4.670	.7549	.1009	.0180	55.64
	26.00	4.548	.7090	.0948	.0169	59.24
<b>5<sup>3</sup>/<sub>4</sub></b>	14.00	5.290	1.0068	.1346	.0240	41.72
	17.00	5.190	.9640	.1289	.0230	43.57
	19.50	5.090	.9221	.1233	.0220	45.55
	22.50	4.990	.8810	.1178	.0210	47.67
	25.20	4.890	.8407	.1124	.0200	49.96
<b>6</b>	15.00	5.524	1.1100	.1484	.0264	37.84
	16.00	5.500	1.0993	.1469	.0262	38.21
	17.00	5.450	1.0769	.1440	.0256	39.00
	18.00	5.424	1.0654	.1424	.0254	39.42
	20.00	5.352	1.0337	.1382	.0246	40.63
	23.00	5.240	.9853	.1317	.0235	42.63
	26.00	5.140	.9396	.1256	.0224	44.70



## Annular Volume Between Three Strings of Tubing and Casing

Tubing O.D. 1.050 in.

No allowance made for upsets and couplings.

C

Casing			Capacity			
O.D. in.	Weight lb/ft	I.D. in.	Gallons per Lineal Foot	Cubic Feet per Lineal Foot	Barrels per Lineal Foot	Lineal Feet per Barrel
6 <sup>5/8</sup>	13.00	6.255	1.4614	.1954	.0348	28.74
	17.00	6.135	1.4007	.1872	.0333	29.99
	20.00	6.049	1.3579	.1815	.0323	30.93
	22.00	5.989	1.3285	.1776	.0316	31.62
	24.00	5.921	1.2954	.1732	.0308	32.42
	26.00	5.855	1.2637	.1689	.0301	33.24
	28.00	5.791	1.2333	.1649	.0294	34.05
	29.00	5.761	1.2192	.1630	.0290	34.45
	32.00	5.675	1.1790	.1576	.0281	35.62
	34.00	5.595	1.1423	1.1423	.1527	.0272
7	17.00	6.538	1.6091	.2151	.0383	26.10
	20.00	6.456	1.5656	.2093	.0373	26.83
	22.00	6.398	1.5352	.2052	.0366	27.36
	23.00	6.366	1.5185	.2030	.0362	27.66
	24.00	6.336	1.5030	.2009	.0358	27.94
	26.00	6.276	1.4721	.1968	.0350	28.53
	28.00	6.214	1.4405	.1926	.0343	29.16
	29.00	6.184	1.4253	.1905	.0339	29.47
	30.00	5.154	1.4102	.1885	.0336	29.78
	32.00	6.094	1.3802	.1845	.0329	30.43
	33.70	6.048	1.3574	.1815	.0323	30.94
	34.00	6.040	1.3535	.1809	.0322	31.03
	35.00	6.004	1.3358	.1786	.0318	31.44
	35.30	6.000	1.3339	.1783	.0318	31.49
	38.00	5.920	1.2949	.1731	.0308	32.43
40.00	5.836	1.2547	.1677	.0299	33.48	
41.00	5.820	1.2470	.1667	.0297	33.68	
44.00	5.720	1.2000	1.2000	.1604	.0286	35.00
7 <sup>5/8</sup>	20.00	7.125	1.9363	.2588	.0461	21.69
	24.00	7.025	1.8786	.2511	.0447	22.36
	26.40	6.969	1.8466	.2469	.0440	22.74
	29.70	6.875	1.7935	.2398	.0427	23.42
	33.70	6.765	1.7323	.2316	.0412	24.25
	36.00	6.705	1.6993	.2272	.0405	24.72
	38.00	6.655	1.6720	.2235	.0398	25.12
	39.00	6.625	1.6558	.2213	.0394	25.37
	45.30	6.435	1.5545	1.5545	.2078	.0370

## Annular Volume Between Three Strings of Tubing and Casing

Tubing O.D. 1.315 in.

No allowance made for upsets and couplings.

Casing			Capacity			
O.D. in.	Weight lb/ft	I.D. in.	Gallons per Lineal Foot	Cubic Feet per Lineal Foot	Barrels per Lineal Foot	Lineal Feet per Barrel
4 1/2	9.50	4.090	.4708	.0629	.0112	89.20
	10.50	4.052	.4582	.0613	.0109	91.66
	11.60	4.000	.4411	.0590	.0105	95.21
	12.60	3.958	.4275	.0751	.0102	98.24
	13.50	3.920	.4153	.0555	.0099	101.13
	15.10	3.826	.3856	.0515	.0092	108.93
	16.60	3.754	.3633	.0486	.0087	115.60
	17.70	3.697	.3460	.0463	.0082	121.39
	18.80	3.640	.3289	.0440	.0078	127.69
4 3/4	16.00	4.082	.4682	.0626	.0111	89.71
5	11.50	4.560	.6367	.0851	.0152	65.96
	13.00	4.494	.6123	.0819	.0146	68.59
	15.00	4.408	.5811	.0777	.0138	72.28
	18.00	4.276	.5343	.0714	.0127	78.60
	20.30	4.184	.5026	.0672	.0120	83.57
	21.00	4.154	.4924	.0658	.0117	85.30
	23.20	4.044	.4556	.0609	.0108	92.19
5 1/2	13.00	5.044	.8264	.1105	.0197	50.82
	14.00	5.012	.8132	.1087	.0194	51.65
	15.00	4.974	.7978	.1066	.0190	52.65
	15.50	4.950	.7880	.1053	.0188	53.30
	17.00	4.892	.7648	.1022	.0182	54.92
	20.00	4.778	.7198	.0962	.0171	58.35
	23.00	4.670	.6781	.0907	.0161	61.93
	26.00	4.548	.6323	.0845	.0151	66.43
5 3/4	14.00	5.290	.9301	.1243	.0221	45.16
	17.00	5.190	.8873	.1186	.0211	47.33
	19.50	5.090	.8454	.1130	.0201	49.68
	22.50	4.990	.8043	.1075	.0191	52.22
	25.20	4.890	.7640	.1021	.0182	54.98
6	15.00	5.524	1.0333	.1381	.0246	40.65
	16.00	5.500	1.0225	.1367	.0243	41.07
	17.00	5.450	1.0002	.1337	.0238	41.99
	18.00	5.424	.9887	.1322	.0235	42.48
	20.00	5.352	.9570	.1279	.0228	43.89
	23.00	5.240	.9086	.1215	.0216	46.22
	26.00	5.140	.8629	.1154	.0205	48.67





## Annular Volume Between Three Strings of Tubing and Casing

Tubing O.D. 1.315 in.

No allowance made for upsets and couplings.

C

Casing			Capacity			
O.D. in.	Weight lb/ft	I.D. in.	Gallons per Lineal Foot	Cubic Feet per Lineal Foot	Barrels per Lineal Foot	Lineal Feet per Barrel
6 <sup>5/8</sup>	13.00	6.255	1.3846	.1851	.0330	30.33
	17.00	6.135	1.3240	.1770	.0315	31.72
	20.00	6.049	1.2812	.1713	.0305	32.78
	22.00	5.989	1.2518	.1673	.0298	33.55
	24.00	5.921	1.2187	.1629	.0290	34.46
	26.00	5.855	1.1870	.1587	.0283	35.38
	28.00	5.791	1.1566	.1546	.0275	36.31
	29.00	5.761	1.1425	.1527	.0272	36.76
	32.00	5.675	1.1023	.1474	.0262	38.10
	34.00	5.595	1.0655	1.0655	.1424	.0254
7	17.00	6.538	1.5324	.2048	.0365	27.41
	20.00	6.456	1.4889	.1990	.0354	28.21
	22.00	6.398	1.4585	.1950	.0347	28.80
	23.00	6.366	1.4418	.1927	.0343	29.13
	24.00	6.336	1.4263	.1907	.0340	29.45
	26.00	6.276	1.3954	.1865	.0332	30.10
	28.00	6.214	1.3638	.1823	.0325	30.80
	29.00	6.184	1.3486	.1803	.0321	31.14
	30.00	6.154	1.3335	.1783	.0318	31.50
	32.00	6.094	1.3035	.1743	.0310	32.22
	33.70	6.048	1.2807	.1712	.0305	32.79
	34.00	6.040	1.2768	.1707	.0304	32.90
	35.00	6.004	1.2591	.1683	.0300	33.36
	35.30	6.000	1.2571	.1681	.0299	33.41
	38.00	5.920	1.2182	.1629	.0290	34.48
40.00	5.836	1.1779	.1575	.0280	35.66	
41.00	5.820	1.1703	.1565	.0279	35.89	
44.00	5.720	1.1233	1.1233	.1502	.0267	37.39
7 <sup>5/8</sup>	20.00	7.125	1.8596	.2486	.0443	22.59
	24.00	7.025	1.8018	.2409	.0429	23.31
	26.40	6.969	1.7699	.2366	.0421	23.73
	29.70	6.875	1.7168	.2295	.0409	24.46
	33.70	6.765	1.6556	.2213	.0394	25.37
	36.00	6.705	1.6226	.2169	.0386	25.88
	38.00	6.655	1.5953	.2133	.0380	26.33
	39.00	6.625	1.5791	.2111	.0376	26.60
	45.30	6.435	1.4778	1.4778	.1976	.0352

## Annular Volume Between Three Strings of Tubing and Casing

Tubing O.D. 1.660 in.

No allowance made for upsets and couplings.

Casing			Capacity			
O.D. in.	Weight lb/ft	I.D. in.	Gallons per Lineal Foot	Cubic Feet per Lineal Foot	Barrels per Lineal Foot	Lineal Feet per Barrel
5	11.50	4.560	.5111	.0683	.0122	82.18
	13.00	4.494	.4867	.0651	.0116	86.29
	15.00	4.408	.4555	.0609	.0108	92.21
	18.00	4.276	.4087	.0546	.0097	102.76
	20.30	4.184	.3370	.0504	.0090	111.42
	21.00	4.154	.3667	.0490	.0087	114.52
	23.20	4.044	.3300	.0441	.0079	127.29
5 <sup>1/2</sup>	13.00	5.044	.7007	.0937	.0167	59.94
	14.00	5.012	.6876	.0919	.0164	61.08
	15.00	4.974	.6721	.0899	.0160	62.49
	15.50	4.950	.6624	.0886	.0158	63.40
	17.00	4.892	.6391	.0854	.0152	65.71
	20.00	4.778	.5941	.0794	.0141	70.69
	23.00	4.670	.5525	.0739	.0132	76.02
26.00	4.548	.5066	.0677	.0121	82.90	
5 <sup>3/4</sup>	14.00	5.290	.8045	.1075	.0192	52.21
	17.00	5.190	.7617	.1018	.0181	55.14
	19.50	5.090	.7198	.0962	.0171	58.35
	22.50	4.990	.6786	.0907	.0162	61.89
	25.20	4.890	.6383	.0853	.0152	65.80
6	15.00	5.524	.9077	.1213	.0216	46.27
	16.00	5.500	.8969	.1199	.0214	46.83
	17.00	5.450	.8746	.1169	.0208	48.02
	18.00	5.424	.8630	.1154	.0205	48.67
	20.00	5.352	.8314	.1111	.0198	50.52
	23.00	5.240	.7830	.1047	.0186	53.64
	26.00	5.140	.7373	.0986	.0176	56.97
6 <sup>5/8</sup>	13.00	6.255	1.2590	.1683	.0300	33.36
	17.00	6.135	1.1984	.1602	.0285	35.05
	20.00	6.049	1.1556	.1545	.0275	36.34
	22.00	5.989	1.1261	.1505	.0268	37.30
	24.00	5.921	1.0931	.1461	.0260	38.42
	26.00	5.855	1.0614	.1419	.0253	39.57
	28.00	5.791	1.0310	.1378	.0245	40.74
	29.00	5.761	1.0168	.1359	.0242	41.30
	32.00	5.675	.9767	.1306	.0233	43.00
	34.00	5.595	.9399	.1256	.0224	44.68



## Annular Volume Between Three Strings of Tubing and Casing

Tubing O.D. 1.660 in.

No allowance made for upsets and couplings.

C

Casing			Capacity			
O.D. in.	Weight lb/ft	I.D. in.	Gallons per Lineal Foot	Cubic Feet per Lineal Foot	Barrels per Lineal Foot	Lineal Feet per Barrel
7	17.00	6.538	1.4067	.1881	.0335	29.86
	20.00	6.456	1.3633	.1822	.0325	30.81
	22.00	6.398	1.3328	.1782	.0317	31.51
	23.00	6.366	1.3162	.1759	.0313	31.91
	24.00	6.336	1.3006	.1739	.0310	32.29
	26.00	6.276	1.2697	.1697	.0302	33.08
	28.00	6.214	1.2382	.1655	.0295	33.92
	29.00	6.184	1.2230	.1635	.0291	34.34
	30.00	6.154	1.2079	.1615	.0288	34.77
	32.00	6.094	1.1779	.1575	.0280	35.66
	33.70	6.048	1.1551	.1544	.0275	36.36
	34.00	6.040	1.1512	.1539	.0274	36.48
	35.00	6.004	1.1335	.1515	.0270	37.05
	35.30	6.000	1.1315	.1513	.0269	37.19
	38.00	5.920	1.0926	.1461	.0260	38.44
	40.00	5.836	1.0523	.1407	.0251	39.91
	41.00	5.820	1.0447	.1397	.0249	40.20
	44.00	5.720	.9976	.1334	.0238	42.10
7 <sup>5</sup> / <sub>8</sub>	20.00	7.125	1.7339	.2318	.0413	24.22
	24.00	7.025	1.6762	.2241	.0399	25.06
	26.40	6.969	1.6442	.2198	.0391	25.54
	29.70	6.875	1.5911	.2127	.0379	26.40
	33.70	6.765	1.5299	.2045	.0364	27.45
	36.00	6.705	1.4970	.2001	.0356	28.06
	38.00	6.655	1.4697	.1965	.0350	28.58
	39.00	6.625	1.4534	.1943	.0346	28.90
	45.30	6.435	1.3522	.1808	.0322	31.06

## Annular Volume Between Three Strings of Tubing and Casing

Tubing O.D. 1.900 in.

No allowance made for upsets and couplings.

Casing			Capacity			
O.D. in.	Weight lb/ft	I.D. in.	Gallons per Lineal Foot	Cubic Feet per Lineal Foot	Barrels per Lineal Foot	Lineal Feet per Barrel
5 <sup>1/2</sup>	13.00	5.044	.5962	.0797	.0142	70.45
	14.00	5.012	.5830	.0779	.0139	72.04
	15.00	4.974	.5676	.0759	.015	74.00
	15.50	4.950	.5578	.0746	.0133	75.29
	17.00	4.892	.5345	.0715	.0127	78.57
	20.00	4.778	.4896	.0654	.0117	85.79
	23.00	4.670	.4479	.0599	.0107	93.76
	26.00	4.548	.4021	.0537	.0096	104.46
5 <sup>3/4</sup>	14.00	5.290	.6999	.0936	.0167	60.01
	17.00	5.190	.6571	.0878	.0156	63.91
	19.50	5.090	.6152	.0822	.0146	68.27
	22.50	4.990	.5741	.0767	.0137	73.16
	25.20	4.890	.5337	.0714	.0127	78.69
6	15.00	5.524	.8031	.1074	.0191	52.30
	16.00	5.500	.7923	.1059	.0189	53.01
	17.00	5.450	.7700	.1029	.0183	54.56
	18.00	5.424	.7585	.1014	.0181	55.38
	20.00	5.352	.7268	.0972	.0173	57.79
	23.00	5.240	.6784	.0907	.0162	61.91
	26.00	5.140	.6361	.0850	.0151	66.03
6 <sup>5/8</sup>	13.00	6.255	1.1544	.1543	.0275	36.38
	17.00	6.135	1.0938	.1462	.0260	38.40
	20.00	6.049	1.0510	.1405	.0250	39.96
	22.00	5.989	1.0216	.1366	.0243	41.11
	24.00	5.921	.9885	.1321	.0235	42.49
	26.00	5.855	.9568	.1279	.0228	43.90
	28.00	5.791	.9264	.1238	.0221	45.34
	29.00	5.761	.9123	.1220	.0217	46.04
	32.00	5.675	.8721	.1166	.0208	48.16
	34.00	5.595	.8353	.1117	.0199	50.28
7	17.00	6.538	1.3021	.1741	.0310	32.25
	20.00	6.456	1.2587	.1683	.0300	33.37
	22.00	6.398	1.2283	.1642	.0292	34.19
	23.00	6.366	1.2116	.1620	.0288	34.67
	24.00	6.336	1.1960	.1599	.0285	35.12
	26.00	6.276	1.1652	.1558	.0277	36.05
	28.00	6.214	1.1336	.1515	.0270	37.05



## Annular Volume Between Three Strings of Tubing and Casing

Tubing O.D. 1.900 in.

No allowance made for upsets and couplings.

C

Casing			Capacity			
O.D. in.	Weight lb/ft	I.D. in.	Gallons per Lineal Foot	Cubic Feet per Lineal Foot	Barrels per Lineal Foot	Lineal Feet per Barrel
7	29.00	6.184	1.1184	.1495	.0266	37.55
	30.00	6.154	1.1033	.1475	.0263	38.07
	32.00	6.094	1.0733	.1435	.0256	39.13
	33.70	6.048	1.0505	.1404	.0250	39.98
	34.00	6.040	1.0466	.1399	.0249	40.13
	35.00	6.004	1.0289	.1375	.0245	40.82
	35.30	6.000	1.0269	.1373	.0245	40.90
	38.00	5.920	.9880	.1321	.0235	42.51
	40.00	5.836	.9477	.1267	.0226	44.32
	41.00	5.820	.9401	.1257	.0224	44.67
44.00	5.720	.8930	.1194	.0213	47.03	
7 <sup>5</sup> / <sub>8</sub>	20.00	7.125	1.6294	.2178	.0388	25.78
	24.00	7.025	1.5716	.2101	.0374	26.72
	26.40	6.969	1.5397	.2058	.0367	27.28
	29.70	6.875	1.4866	.1987	.0354	28.25
	33.70	6.765	1.4254	.1905	.0339	29.47
	36.00	6.705	1.3924	.1861	.0332	30.16
	38.00	6.655	1.3651	.1825	.0325	30.77
	39.00	6.625	1.3489	.1803	.0321	31.14
45.30	6.435	1.2476	.1688	.0297	33.66	
7 <sup>3</sup> / <sub>4</sub>	46.10	6.560	1.3139	.1756	.0313	31.97
8 <sup>5</sup> / <sub>8</sub>	24.00	8.097	2.2330	.2985	.0532	18.81
	28.00	8.017	2.1804	.2915	.0519	19.26
	32.00	7.921	2.1180	.2831	.0504	19.83
	36.00	7.825	2.0563	.2749	.0490	20.42
	38.00	7.775	2.0245	.2706	.0482	20.75
	40.00	7.725	1.9929	.2664	.0474	21.07
	43.00	7.651	1.9465	.2602	.0463	21.58
	44.00	7.625	1.9303	.2580	.0460	21.76
	48.00	7.537	1.8758	.2508	.0447	22.39
	49.00	7.511	1.8599	.2486	.0443	22.58

## Annular Volume Between Three Strings of Tubing and Casing

Tubing O.D. 1.900 in.

No allowance made for upsets and couplings.

Casing			Capacity			
O.D. in.	Weight lb/ft	I.D. in.	Gallons per Lineal Foot	Cubic Feet per Lineal Foot	Barrels per Lineal Foot	Lineal Feet per Barrel
9 <sup>5</sup> / <sub>8</sub>	29.30	9.063	2.9094	.3889	.0693	14.44
	32.30	9.001	2.8637	.3828	.0682	14.67
	36.00	8.921	2.8052	.3750	.0668	14.97
	38.00	8.885	2.7790	.3715	.0662	15.11
	40.00	8.835	2.7429	.3667	.0653	15.31
	42.00	8.799	2.7170	.3632	.0647	15.46
	43.50	8.755	2.6855	.3590	.0639	15.64
	47.00	8.681	2.6328	.3520	.0627	15.95
	53.50	8.535	2.5303	.3382	.0602	16.60
	58.40	8.435	2.4610	.3290	.0586	17.06
	61.10	8.375	2.4199	.3235	.0576	17.36
	71.80	8.125	2.2516	.3010	.0536	18.65



## Annular Volume Between Three Strings of Tubing and Casing

Tubing O.D. 2.063 in.

No allowance made for upsets and couplings.

C

Casing			Capacity			
O.D. in.	Weight lb/ft	I.D. in.	Gallons per Lineal Foot	Cubic Feet per Lineal Foot	Barrels per Lineal Foot	Lineal Feet per Barrel
5 <sup>1/2</sup>	13.00	5.044	.5171	.0691	.0123	81.22
	14.00	5.012	.5040	.0674	.0120	83.34
	15.00	4.974	.4885	.0653	.0116	85.98
	15.50	4.950	.4788	.0640	.0114	87.72
	17.00	4.892	.4555	.0609	.0108	92.21
	20.00	4.778	.4105	.0549	.0098	102.31
	23.00	4.670	.3689	.0493	.0088	113.86
	26.00	4.548	.3235	.0432	.0077	129.83
5 <sup>3/4</sup>	14.00	5.290	.6208	.0830	.0148	67.65
	17.00	5.190	.5781	.0773	.0138	72.66
	19.50	5.090	.5361	.0717	.0128	78.34
	22.50	4.990	.4950	.0662	.0118	84.85
	25.20	4.890	.4547	.0608	.0108	92.37
6	15.00	5.524	.7241	.0968	.0172	58.01
	16.00	5.500	.7133	.0954	.0170	58.88
	17.00	5.450	.6909	.0924	.0165	60.79
	18.00	5.424	.6794	.0908	.0162	61.82
	20.00	5.352	.6477	.0866	.0154	64.84
	23.00	5.240	.5993	.0801	.0143	70.08
6 <sup>5/8</sup>	13.00	6.255	1.0754	.1438	.0256	39.06
	17.00	6.135	1.0147	.1356	.0242	41.39
	20.00	6.049	.9720	.1299	.0231	43.21
	22.00	5.989	.9425	.1260	.0224	44.56
	24.00	5.921	.9094	.1216	.0217	46.18
	26.00	5.855	.8777	.1173	.0209	47.85
	28.00	5.791	.8473	.1133	.0202	49.57
	29.00	5.761	.8332	.1114	.0198	50.41
	32.00	5.675	.7931	.1060	.0189	52.96
	34.00	5.595	.7563	.1011	.0180	55.54

## Annular Volume Between Three Strings of Tubing and Casing

Tubing O.D. 2.063 in.

No allowance made for upsets and couplings.

Casing			Capacity			
O.D. in.	Weight lb/ft	I.D. in.	Gallons per Lineal Foot	Cubic Feet per Lineal Foot	Barrels per Lineal Foot	Lineal Feet per Barrel
7	17.00	6.538	1.2231	.1635	.0291	34.34
	20.00	6.456	1.1796	.1577	.0281	35.61
	22.00	6.398	1.1492	.1536	.0274	36.65
	23.00	6.366	1.1325	.1514	.0270	37.09
	24.00	6.336	1.1170	.1493	.0266	37.60
	26.00	6.276	1.0861	.1452	.0259	38.67
	28.00	6.214	1.0545	.1410	.0251	39.83
	29.00	6.184	1.0393	.1389	.0247	40.41
	30.00	6.154	1.0242	.1369	.0244	41.01
	32.00	6.094	.9942	.1329	.0237	42.24
	33.70	6.048	.9715	.1299	.0231	43.23
	34.00	6.040	.9675	.1293	.0230	43.41
	35.00	6.004	.9498	.1270	.0226	44.22
	35.30	6.000	.9479	.1267	.0226	44.31
	38.00	5.920	.9090	.1215	.0216	46.21
	40.00	5.836	.8687	.1161	.0207	48.35
	41.00	5.820	.8611	.1151	.0205	48.78
44.00	5.720	.8140	.1088	.0194	51.60	
7 <sup>7</sup> / <sub>8</sub>	20.00	7.125	1.5503	.2072	.0369	27.09
	24.00	7.025	1.4926	.1995	.0355	28.14
	26.40	6.969	1.4606	.1953	.0348	28.76
	29.70	6.875	1.4075	.1882	.0335	29.84
	33.70	6.765	1.3463	.1800	.0321	31.20
	36.00	6.705	1.3133	.1756	.0313	31.98
	38.00	6.655	1.2861	.1719	.0306	32.66
	39.00	6.625	1.2698	.1697	.0302	33.08
	45.30	6.435	1.1686	.1562	.0278	35.94
7 <sup>3</sup> / <sub>4</sub>	46.10	6.560	1.2348	.1651	.0294	34.01

C



## Annular Volume Between Three Strings of Tubing and Casing

Tubing O.D. 2.063 in.

No allowance made for upsets and couplings.

C

Casing			Capacity			
O.D. in.	Weight lb/ft	I.D. in.	Gallons per Lineal Foot	Cubic Feet per Lineal Foot	Barrels per Lineal Foot	Lineal Feet per Barrel
8 <sup>5</sup> / <sub>8</sub>	24.00	8.097	2.1540	.2879	.0513	19.50
	28.00	8.017	2.1014	.2809	.0500	19.99
	32.00	7.921	2.0389	.2726	.0485	20.60
	36.00	7.825	1.9773	.2643	.0471	21.24
	38.00	7.775	1.9455	.2601	.0463	21.59
	40.00	7.725	1.9138	.2558	.0456	21.95
	43.00	7.651	1.8674	.2496	.0445	22.49
	44.00	7.625	1.8512	.2475	.0441	22.69
	48.00	7.537	1.7968	.2402	.0428	23.38
	49.00	7.511	1.7808	.2381	.0424	23.58
9 <sup>5</sup> / <sub>8</sub>	29.30	9.063	2.8303	.3784	.0674	14.84
	32.30	9.001	2.7846	.3722	.0663	15.08
	36.00	8.921	2.7261	.3644	.0649	15.41
	38.00	8.885	2.6941	.3602	.0641	15.59
	40.00	8.835	2.6638	.3651	.0634	15.77
	42.00	8.799	2.6379	.3526	.0628	15.92
	43.50	8.755	2.6064	.3484	.0621	16.11
	47.00	8.681	2.5537	.3414	.0608	16.45
	53.50	8.535	2.4512	.3277	.0584	17.13
13 <sup>3</sup> / <sub>8</sub>	48.00	12.715	6.0752	.8121	.1446	6.91
	54.50	12.615	5.9719	.7983	.1422	7.03
	61.00	12.515	5.8694	.7846	.1397	7.16
	68.00	12.415	5.7677	.7710	.1373	7.28
	72.00	12.347	5.6990	.7618	.1357	7.37
	83.00	12.175	5.5269	.7388	.1316	7.60

## Annular Volume Between Three Strings of Tubing and Casing

Tubing O.D. 2.375 in.

No allowance made for upsets and couplings.

Casing			Capacity			
O.D. in.	Weight lb/ft	I.D. in.	Gallons per Lineal Foot	Cubic Feet per Lineal Foot	Barrels per Lineal Foot	Lineal Feet per Barrel
6 <sup>5</sup> / <sub>8</sub>	13.00	6.255	.9033	.1208	.0215	46.49
	17.00	6.135	.8452	.1130	.0201	49.69
	20.00	6.049	.8025	.1073	.0191	52.34
	22.00	5.989	.7730	.1033	.0184	54.33
	24.00	5.921	.7400	.0989	.0176	56.76
	26.00	5.855	.7083	.0947	.0169	59.30
	28.00	5.791	.6778	.0906	.0161	61.96
	29.00	5.761	.6637	.0887	.0158	63.28
	32.00	5.675	.6236	.0834	.0148	67.35
	34.00	5.595	.5868	.0784	.0140	71.58
7	17.00	6.538	1.0536	.1408	.0251	39.86
	20.00	6.456	1.0101	.1350	.0241	41.58
	22.00	6.398	.9797	.1310	.0233	42.87
	23.00	6.366	.9630	.1287	.0229	43.61
	24.00	6.336	.9475	.1267	.0226	44.33
	26.00	6.276	.9166	.1225	.0218	45.82
	28.00	6.214	.8850	.1183	.0211	47.46
	29.00	6.184	.8699	.1163	.0207	48.28
	30.00	6.154	.8548	.1143	.0204	49.14
	32.00	6.094	.8248	.1103	.0196	50.92
	33.70	6.048	.8020	.1072	.0191	52.37
	34.00	6.040	.7980	.1067	.0190	52.63
	35.00	6.004	.7803	.1043	.0186	53.82
	35.30	6.000	.7784	.1041	.0185	53.96
	38.00	5.920	.7395	.0989	.0176	56.80
	40.00	5.836	.6992	.0935	.0166	60.07
41.00	5.820	.6916	.0916	.0165	60.73	
44.00	5.720	.6445	.0862	.0153	65.17	
7 <sup>5</sup> / <sub>8</sub>	20.00	7.125	1.3808	.1846	.0329	30.42
	24.00	7.025	1.3231	.1769	.0315	31.74
	26.40	6.969	1.2911	.1726	.0307	32.53
	29.70	6.875	1.2380	.1655	.0295	33.93
	33.70	6.765	1.1768	.1573	.0280	35.69
	36.00	6.705	1.1438	.1529	.0272	36.72
	38.00	6.655	1.1166	.1493	.0266	37.62
	39.00	6.625	1.1003	.1471	.0262	38.17
	45.30	6.435	.9991	.1336	.0238	42.04



## Annular Volume Between Three Strings of Tubing and Casing

Tubing O.D. 2.375 in.

No allowance made for upsets and couplings.

C

Casing			Capacity			
O.D. in.	Weight lb/ft	I.D. in.	Gallons per Lineal Foot	Cubic Feet per Lineal Foot	Barrels per Lineal Foot	Lineal Feet per Barrel
7 <sup>3</sup> / <sub>4</sub>	46.10	6.560	1.0653	.1424	.0254	39.42
8	26.00	7.386	1.5363	.2052	.0366	27.36
8 <sup>1</sup> / <sub>8</sub>	28.00	7.485	1.5954	.2133	.0380	26.33
	32.00	7.385	1.5347	.2052	.0365	27.37
	35.50	7.285	1.4749	.1972	.0351	28.48
	39.50	7.185	1.4159	.1893	.0337	29.66
8 <sup>5</sup> / <sub>8</sub>	24.00	8.097	1.9845	.2653	.0472	21.16
	28.00	8.017	1.9319	.2583	.0460	21.74
	32.00	7.921	1.8695	.2499	.0445	22.47
	36.00	7.825	1.8078	.2417	.0430	23.23
	38.00	7.775	1.7760	.2374	.0423	23.65
	40.00	7.725	1.7443	.2332	.0415	24.08
	43.00	7.651	1.6979	.2270	.0404	24.74
	44.00	7.625	1.6817	.2248	.0400	24.97
48.00	7.537	1.6886	.2257	.0402	25.81	
49.00	7.511	1.6113	.2154	.0384	26.07	
8 <sup>3</sup> / <sub>4</sub>	49.70	7.636	1.6273	.2175	.0387	24.87
9	34.00	8.290	2.1135	.2825	.0503	19.87
	38.00	8.196	2.0503	.2741	.0488	20.48
	40.00	8.150	2.0196	.2700	.0481	20.80
	45.00	8.032	1.9417	.2596	.0462	21.63
	50.20	7.910	1.8624	.2490	.0443	22.55
55.00	7.812	1.7995	.2406	.0428	23.34	
9 <sup>5</sup> / <sub>8</sub>	29.30	9.063	2.6608	.3557	.0634	15.78
	32.30	9.001	2.6151	.3496	.0623	16.06
	36.00	8.921	2.5566	.3418	.0609	16.43
	38.00	8.885	2.5247	.3375	.0601	16.64
	40.00	8.835	2.4943	.3334	.0594	16.84
	42.00	8.799	2.4684	.3300	.0588	17.02
	43.50	8.755	2.4369	.3258	.0580	17.24
	47.00	8.681	2.3843	.3187	.0568	17.62
	53.50	8.535	2.2817	.3050	.0543	18.41
	58.40	8.435	2.2125	.2958	.0527	18.98
	61.10	8.375	2.1713	.2903	.0517	19.34
71.80	8.125	2.0030	.2678	.0477	20.97	

## Annular Volume Between Three Strings of Tubing and Casing

Tubing O.D. 2.375 in.

No allowance made for upsets and couplings.

Casing			Capacity			
O.D. in.	Weight lb/ft	I.D. in.	Gallons per Lineal Foot	Cubic Feet per Lineal Foot	Barrels per Lineal Foot	Lineal Feet per Barrel
9 <sup>3</sup> / <sub>4</sub>	59.20	8.560	2.2991	.3074	.0547	18.27
9 <sup>7</sup> / <sub>8</sub>	62.80	8.625	2.3447	.3134	.0558	17.91
10	33.00 41.50 45.50 50.50 55.50 61.20	9.384 9.200 9.120 9.016 8.908 8.790	2.9024 2.7629 2.7031 2.6261 2.5472 2.4620	.3880 .3693 .3614 .3511 .3405 .3291	.0691 .0658 .0644 .0625 .0606 .0586	14.47 15.20 15.54 15.99 16.49 17.06
10 <sup>3</sup> / <sub>4</sub>	32.75 35.75 40.50 45.50 48.00 51.00 54.00 55.50 60.70 65.70	11.192 10.136 10.050 9.950 9.902 9.850 9.784 9.760 9.660 9.560	3.5478 3.5013 3.4305 3.3489 3.3100 3.2681 3.2152 3.1961 3.1169 3.0384	.4743 .4681 .4586 .4477 .4425 .4369 .4298 .4273 .4167 .4062	.0845 .0834 .0817 .0797 .0788 .0778 .0766 .0761 .0742 .0723	11.84 12.00 12.24 12.54 12.69 12.85 13.06 13.14 13.48 13.82
11 <sup>3</sup> / <sub>4</sub>	38.00 42.00 47.00 54.00 60.00	11.150 11.084 11.000 10.880 10.772	4.3819 4.3221 4.2464 4.1393 4.0438	.5858 .5778 .5677 .5533 .5406	.1043 .1029 .1011 .0986 .0963	9.58 9.72 9.89 10.15 10.39
13 <sup>3</sup> / <sub>8</sub>	48.00 54.50 61.00 68.00 72.00 77.00 83.00	12.715 12.615 12.515 12.415 12.347 12.275 12.175	5.9058 5.8024 5.6999 5.5982 5.5295 5.4571 5.3574	.7895 .7757 .7620 .7484 .7392 .7295 .7162	.1406 .1382 .1357 .1333 .1317 .1299 .1276	7.11 7.24 7.37 7.50 7.60 7.70 7.84
16	55.00 65.00 70.00 75.00 84.00	15.375 15.250 15.198 15.125 15.010	8.9556 8.7981 8.7335 8.6420 8.5018	1.1972 1.1761 1.1675 1.1553 1.1365	.2132 .2095 .2079 .2058 .2024	4.69 4.77 4.81 4.86 4.94



## Annular Volume Between Three Strings of Tubing and Casing

Tubing O.D. 2.875 in.

No allowance made for upsets and couplings.

C

Casing			Capacity			
O.D. in.	Weight lb/ft	I.D. in.	Gallons per Lineal Foot	Cubic Feet per Lineal Foot	Barrels per Lineal Foot	Lineal Feet per Barrel
8	26.00	7.386	1.2140	.1623	.0289	34.60
8 <sup>1</sup> / <sub>8</sub>	28.00	7.485	1.2741	.1703	.0303	32.96
	32.00	7.385	1.2134	.1622	.0289	34.61
	35.50	7.285	1.1536	.1542	.0275	36.41
	39.50	7.185	1.0946	.1463	.0261	38.37
8 <sup>5</sup> / <sub>8</sub>	24.00	8.097	1.6632	.2223	.0396	25.25
	28.00	8.017	1.6106	.2153	.0383	26.08
	32.00	7.921	1.5482	.2070	.0369	27.13
	36.00	7.825	1.4865	.1987	.0354	28.25
	38.00	7.775	1.4547	.1945	.0346	28.87
	40.00	7.725	1.4230	.1902	.0339	29.51
	43.00	7.651	1.3766	.1840	.0328	30.51
	44.00	7.625	1.3604	.1819	.0324	30.87
8 <sup>3</sup> / <sub>4</sub>	48.00	7.537	1.3060	.1746	.0311	32.16
	49.00	7.511	1.2900	.1725	.0307	32.56
9	49.70	7.636	1.3673	.1828	.0326	30.72
9	34.00	8.290	1.7922	.2396	.0427	23.43
	38.00	8.196	1.7290	.2311	.0412	24.29
	40.00	8.150	1.6983	.2270	.0404	24.73
	45.00	8.032	1.6204	.2166	.0386	25.92
	50.20	7.910	1.5411	.2060	.0367	27.25
9 <sup>5</sup> / <sub>8</sub>	55.00	7.812	1.4782	.1976	.0352	28.41
	29.30	9.063	2.3395	.3127	.0557	17.95
	32.30	9.001	2.2938	.3066	.0546	18.31
	36.00	8.921	2.2353	.2988	.0532	18.79
	38.00	8.885	2.2034	.2945	.0525	19.06
	40.00	8.835	2.1730	.2905	.0517	19.33
	42.00	8.799	2.1471	.2870	.0511	19.56
	43.50	8.755	2.1156	.2828	.0504	19.85
	47.00	8.681	2.0630	.2758	.0491	20.36
	53.50	8.535	1.9604	.2621	.0467	21.42
58.40	8.435	1.8912	.2528	.0450	22.21	
61.10	8.375	1.8500	.2473	.0440	22.70	
71.80	8.125	1.6817	.2248	.0400	24.97	

## Annular Volume Between Three Strings of Tubing and Casing

Tubing O.D. 2.875 in.

No allowance made for upsets and couplings.

Casing			Capacity			
O.D. in.	Weight lb/ft	I.D. in.	Gallons per Lineal Foot	Cubic Feet per Lineal Foot	Barrels per Lineal Foot	Lineal Feet per Barrel
9 <sup>3</sup> / <sub>4</sub>	59.20	8.560	1.9778	.2644	.0471	21.24
9 <sup>7</sup> / <sub>8</sub>	62.80	8.625	2.0234	.2705	.0482	20.76
10	33.00 41.50 45.50 50.50 55.50 61.20	9.384 9.200 9.120 9.016 8.908 8.790	2.5811 2.4416 2.3818 2.3048 2.2259 2.1407	.3450 .3264 .3184 .3081 .2976 .2862	.0615 .0581 .0567 .0549 .0530 .0510	16.27 17.20 17.63 18.22 18.87 19.62
10 <sup>3</sup> / <sub>4</sub>	32.75 35.75 40.50 45.50 48.00 51.00 54.00 55.50 60.70 65.70 71.10 76.00 81.00	10.192 10.136 10.050 9.950 9.902 9.850 9.784 9.760 9.660 9.560 9.450 9.350 9.250	3.2265 3.1800 3.1092 3.0276 2.9887 2.9468 2.8939 2.8748 2.7956 2.7171 2.6318 2.5551 2.4792	.4313 .4251 .4156 .4047 .3995 .3939 .3869 .3843 .3737 .3632 .3518 .3416 .3314	.0768 .0757 .0740 .0721 .0712 .0702 .0689 .0684 .0666 .0647 .0627 .0608 .0590	13.02 13.21 13.51 13.87 14.05 14.25 14.51 14.61 15.02 15.46 15.96 16.44 16.94
11 <sup>3</sup> / <sub>4</sub>	38.00 42.00 47.00 54.00 60.00 65.00 71.00	11.150 11.084 11.000 10.880 10.772 10.682 10.586	4.0606 4.0008 3.9251 3.8180 3.7225 3.6438 3.5605	.5428 .5348 .5247 .5104 .4976 .4871 .4760	.0967 .0953 .0935 .0909 .0886 .0868 .0848	10.34 10.50 10.70 11.00 11.28 11.53 11.80
13 <sup>3</sup> / <sub>8</sub>	48.00 54.50 61.00 68.00 72.00 83.00	12.715 12.615 12.515 12.415 12.347 12.175	5.5845 5.4811 5.3786 5.2769 5.2082 5.0361	.7465 .7327 .7190 .7054 .6962 .6732	.1330 .1305 .1281 .1256 .1240 .1199	7.52 7.66 7.81 7.96 8.06 8.34



## Annular Volume Between Three Strings of Tubing and Casing

Tubing O.D. 2.875 in.

No allowance made for upsets and couplings.

Casing			Capacity			
O.D. in.	Weight lb/ft	I.D. in.	Gallons per Lineal Foot	Cubic Feet per Lineal Foot	Barrels per Lineal Foot	Lineal Feet per Barrel
16	55.00	15.375	8.6343	1.1542	.2056	4.86
	65.00	15.250	8.4768	.883	.2018	4.95
	70.00	15.198	8.4122	1.1246	.2003	4.99
	75.00	15.125	8.3207	1.1123	.1981	5.05
	84.00	15.010	8.1805	1.0936	.1948	5.13

C

## Annular Volume Between Three Strings of Tubing and Casing

Tubing O.D. 3.500 in., 88.9 mm

No allowance made for upsets and couplings.

Casing			Capacity			
O.D. in.	Weight lb/ft	I.D. in.	Gallons per Lineal Foot	Cubic Feet per Lineal Foot	Barrels per Lineal Foot	Lineal Feet per Barrel
9 <sup>5</sup> / <sub>8</sub>	29.30	9.063	1.8518	.2476	.0441	22.68
	32.30	9.001	1.8061	.2414	.0430	23.25
	36.00	8.921	1.7476	.2336	.0416	24.03
	38.00	8.885	1.7157	.2294	.0408	24.48
	40.00	8.835	1.6853	.2253	.0401	24.92
	42.00	8.799	1.6594	.2218	.0395	25.31
	43.50	8.755	1.6279	.2176	.0388	25.80
	47.00	8.681	1.5753	.2106	.0375	26.66
	53.50	8.535	1.4727	.1969	.0351	28.52
	58.40	8.435	1.4035	.1876	.0334	29.93
	61.10	8.375	1.3623	.1821	.0324	30.83
	71.80	8.125	1.1940	.1596	.0284	35.17
9 <sup>3</sup> / <sub>4</sub>	59.20	8.560	1.4902	.1992	.0355	28.18
9 <sup>7</sup> / <sub>8</sub>	62.80	8.625	1.5357	.2053	.0366	27.35
10	33.00	9.384	2.0934	.2798	.0498	20.06
	41.50	9.200	1.9539	.2612	.0465	21.50
	45.50	9.120	1.8941	.2532	.0451	22.17
	50.50	9.016	1.8172	.2429	.0433	23.11
	55.50	8.908	1.7382	.2324	.0414	24.16
	61.20	8.790	1.6530	.2210	.0394	25.41
10 <sup>3</sup> / <sub>4</sub>	32.75	10.192	2.7388	.3661	.0652	15.34
	35.75	10.136	2.6923	.3599	.0641	15.60
	40.50	10.050	2.6215	.3504	.0624	16.02
	45.50	9.950	2.5399	.3395	.0605	16.54
	48.00	9.902	2.8010	.3343	.0595	16.79
	51.00	9.850	2.4591	.3287	.0586	.1708
	54.00	9.784	2.4062	.3217	.0573	17.45
	55.50	9.760	2.3871	.3191	.0568	17.59
	60.70	9.660	2.3079	.3085	.0549	18.20
	65.70	9.560	2.2295	.2980	.0531	18.84
	71.10	9.450	2.1441	.2866	.0511	19.59
	76.00	9.350	2.0674	.2764	.0492	20.32
	81.00	9.250	1.9915	.2662	.0474	21.0892





## Annular Volume Between Three Strings of Tubing and Casing

Tubing O.D. 3.500 in.

No allowance made for upsets and couplings.

C

Casing			Capacity			
O.D. in.	Weight lb/ft	I.D. in.	Gallons per Lineal Foot	Cubic Feet per Lineal Foot	Barrels per Lineal Foot	Lineal Feet per Barrel
11 <sup>3</sup> / <sub>4</sub>	38.00	11.150	3.5729	.4776	.0851	11.76
	42.00	11.084	3.5131	.4696	.0836	11.96
	47.00	11.000	3.4374	.4595	.0818	12.22
	54.00	10.880	3.3303	.4452	.0793	12.61
	60.00	10.772	3.2349	.4324	.0770	12.98
	65.00	10.682	3.1561	.4219	.0751	13.31
	71.00	10.586	3.0728	.4108	.0732	13.67
11 <sup>7</sup> / <sub>8</sub>	71.80	10.711	3.1814	.4253	.0757	13.20
12	40.00	11.384	3.7881	.5064	.0902	11.09
12 <sup>3</sup> / <sub>4</sub>	43.00	12.130	4.5038	.6021	.1072	9.33
	53.00	11.970	4.3465	.5810	.1035	9.66
13	40.00	12.438	4.8125	.6433	.1146	8.73
	45.00	12.360	4.7336	.6328	.1127	8.87
	50.00	12.282	4.6552	.6223	.1108	9.02
	54.00	12.220	4.5932	.6140	.1094	9.14
	48.00	12.715	5.0968	.6813	.1214	8.24
	54.50	12.615	4.9934	.6675	.1189	8.41
13 <sup>3</sup> / <sub>8</sub>	61.00	12.515	4.8909	.6538	.1164	8.59
	68.00	12.415	4.7892	.6402	.1140	8.77
	72.00	12.347	4.7205	.6310	.1124	8.90
	77.00	12.275	4.6482	.6214	.1107	9.04
	83.00	12.175	4.5484	.6080	.1083	9.23
	85.00	12.159	4.5325	.6059	.1079	9.27
	92.00	12.031	4.4062	.5890	.1089	9.53
	98.00	11.937	4.3143	.5767	.1027	9.74
16	55.00	15.375	8.1466	1.0890	.1940	5.16
	65.00	15.250	7.9891	1.0680	.1902	5.26
	70.00	15.198	7.9245	1.0594	.1887	5.30
	75.00	15.125	7.8330	1.0471	.1865	5.36
	84.00	15.010	7.6928	1.0284	.1832	5.46
	109.00	14.688	7.3027	.9762	.1739	5.75
20	90.00	19.166	13.4879	1.8031	.3211	3.11
	94.00	19.124	13.4222	1.7943	.3196	3.13
	106.50	19.000	13.2294	1.7685	.3150	3.17
	133.00	18.730	12.8137	1.7129	.3051	3.28

**Schlumberger**

**Appendix D  
FLUID GRADIENTS**



**D**

## Fluid Gradient Tables

Oil API Gravity	Fluid Weight lb./gal.	Fluid Gradient psi/ft.	Fluid Specific Gravity	Oil API Gravity	Fluid Weight lb./gal.	Fluid Gradient psi/ft.	Fluid Specific Gravity
100	5.10	.265	.611	77	5.66	.294	.679
99	5.12	.266	.614	76	5.69	.296	.682
98	5.14	.267	.617	75	5.71	.297	.685
97	5.16	.268	.619	74	5.74	.299	.689
96	5.19	.270	.622	73	5.77	.300	.692
95	5.21	.271	.625	72	5.80	.301	.695
94	5.23	.272	.627	71	5.83	.303	.699
93	5.25	.273	.630	70	5.85	.304	.702
92	5.28	.274	.633	69	5.88	.306	.706
91	5.30	.276	.636	68	5.91	.307	.709
90	5.33	.277	.639	67	5.94	.309	.713
89	5.35	.278	.642	66	5.97	.311	.716
88	5.37	.279	.645	65	6.00	.312	.720
87	5.40	.281	.648	64	6.03	.314	.724
86	5.42	.282	.651	63	6.07	.315	.728
85	5.45	.283	.654	62	6.10	.317	.731
84	5.47	.285	.657	61	6.13	.319	.735
83	5.50	.286	.660	60	6.16	.320	.739
82	5.53	.287	.663	59	6.19	.322	.743
81	5.55	.289	.666	58	6.23	.324	.747
80	5.58	.290	.669	57	6.26	.325	.751
79	5.60	.291	.672	56	6.29	.327	.755
78	5.63	.293	.675	55	6.33	.329	.759



# D

## Fluid Gradient Tables

Oil API Gravity	Fluid Weight lb./gal.	Fluid Gradient psi/ft.	Fluid Specific Gravity	Oil API Gravity	Fluid Weight lb./gal.	Fluid Gradient psi/ft.	Fluid Specific Gravity
54	6.36	.331	.763	31	7.26	.377	.871
53	6.39	.332	.767	30	7.30	.380	.876
52	6.43	.334	.771	29	7.35	.382	.882
51	6.46	.336	.775	28	7.40	.385	.887
50	6.50	.338	.780	27	7.44	.387	.893
49	6.54	.340	.784	26	7.49	.389	.898
48	6.57	.342	.788	25	7.54	.392	.904
47	6.61	.344	.793	24	7.59	.394	.910
46	6.65	.346	.797	23	7.64	.397	.916
45	6.68	.348	.802	22	7.69	.400	.922
44	6.72	.350	.806	21	7.74	.402	.928
43	6.76	.352	.811	20	7.79	.405	.934
42	6.80	.354	.816	19	7.84	.408	.940
41	6.84	.356	.820	18	7.89	.410	.946
40	6.88	.358	.825	17	7.94	.413	.953
39	6.92	.360	.830	16	8.00	.416	.959
38	6.96	.362	.835	15	8.05	.419	.966
37	7.00	.364	.840	14	8.11	.422	.973
36	7.04	.366	.845	13	8.16	.425	.979
35	7.09	.368	.850	12	8.22	.427	.986
34	7.13	.371	.855	11	8.28	.430	.993
33	7.17	.373	.860	10	8.34	.434	1.000
32	7.22	.375	.865				

## Fluid Gradient Tables

Fluid Weight lb./gal.	Fluid Gradient psi/ft.	Fluid Specific Gravity	Fluid Weight lb./gal.	Fluid Gradient psi/ft.	Fluid Specific Gravity	Fluid Weight lb./gal.	Fluid Gradient psi/ft.	Fluid Specific Gravity
8.34	.434	9.75	10.30	.536	1.235	12.30	.640	1.475
8.40	.437	1.008	10.40	.541	1.247	12.40	.645	1.487
8.50	.442	1.020	10.50	.546	1.259	12.50	.650	1.499
8.60	.447	1.032	10.60	.551	1.271	12.60	.655	1.511
8.70	.452	1.044	10.70	.556	1.283	12.70	.660	1.523
8.80	.458	1.056	10.80	.562	1.295	12.80	.666	1.535
8.90	.463	1.068	10.90	.567	1.307	12.90	.671	1.547
9.00	.468	1.080	11.00	.572	1.319	13.00	.676	1.559
9.10	.473	1.092	11.10	.577	1.331	13.10	.681	1.571
9.20	.478	1.104	11.20	.582	1.343	13.20	.686	1.583
9.30	.484	1.116	11.30	.588	1.355	13.30	.692	1.595
9.40	.489	1.128	11.40	.593	1.367	13.40	.697	1.607
9.50	.494	1.139	11.50	.598	1.279	13.50	.702	1.619
9.60	.499	1.151	11.60	.603	1.391	13.60	.707	1.631
9.70	.504	1.163	11.70	.608	1.403	13.70	.712	1.643
9.80	.510	1.175	11.80	.614	1.415	13.80	.718	1.655
9.90	.515	1.187	11.90	.619	1.427	13.90	.723	1.667
10.00	.520	1.199	12.00	.624	1.439	14.00	.728	1.679
10.10	.525	1.211	12.10	.629	1.451	14.10	.733	1.691
10.20	.530	1.223	12.20	.634	1.463	14.20	.738	1.703



# D

## Fluid Gradient Tables

Fluid Weight lb./gal.	Fluid Gradient psi/ft.	Fluid Specific Gravity
18.30	.952	2.195
18.40	.957	2.207
18.50	.962	2.219
18.60	.967	2.231
18.70	.972	2.243
18.80	.978	2.255
18.90	.983	2.267
19.00	.988	2.279
19.10	.993	2.291
19.20	.998	2.303
19.30	1.004	2.315
19.40	1.009	2.327
19.50	1.014	2.339
19.60	1.019	2.351
19.70	1.024	2.363
19.80	1.030	2.375
19.90	1.035	2.387
20.00	1.040	2.399

Fluid Weight lb./gal.	Fluid Gradient psi/ft.	Fluid Specific Gravity
16.30	.848	1.955
16.40	.853	1.967
16.50	.858	1.979
16.60	.863	1.991
16.70	.868	2.003
16.80	.874	2.015
16.90	.879	2.027
17.00	.884	2.039
17.10	.889	2.051
17.20	.894	2.063
17.30	.900	2.075
17.40	.905	2.087
17.50	.910	2.099
17.60	.915	2.111
17.70	.920	2.123
17.80	.926	2.135
17.90	.931	2.147
18.00	.936	2.159
18.10	.941	2.171
18.20	.946	2.183

Fluid Weight lb./gal.	Fluid Gradient psi/ft.	Fluid Specific Gravity
14.30	.744	1.715
14.40	.749	1.727
14.50	.754	1.739
14.60	.759	1.751
14.70	.764	1.763
14.80	.770	1.775
14.90	.775	1.787
15.00	.780	1.799
15.10	.785	1.811
15.20	.790	1.823
15.30	.796	1.835
15.40	.801	1.847
15.50	.806	1.859
15.60	.811	1.871
15.70	.816	1.883
15.80	.822	1.895
15.90	.827	1.907
16.00	.832	1.919
16.10	.837	1.931
16.20	.842	1.943

## PSI Per Barrel Tables A - Oil

API Oil Gravity	Fluid Gradient psi/ft	PSI per Barrel			
		2 <sup>3</sup> / <sub>8</sub> 4.7 lb/ft EUE Tubing	2 <sup>7</sup> / <sub>8</sub> 6.5 lb/ft EUE Tubing	2 <sup>7</sup> / <sub>8</sub> 10.4 lb/ft IU Drill Pipe	3 <sup>1</sup> / <sub>2</sub> 13.3 lb/ft IU Drill Pipe
100	.265	68.5	45.7	59.8	36.0
99	.266	68.7	45.9	60.0	36.2
98	.267	69.0	46.1	60.2	36.3
97	.268	69.3	46.3	60.4	36.4
96	.270	69.8	46.6	60.9	36.7
95	.271	70.0	46.8	61.1	36.9
94	.272	70.3	46.9	61.3	37.0
93	.276	71.3	47.6	62.2	37.5
92	.274	70.8	47.3	61.8	37.3
91	.276	71.3	47.6	62.2	37.5
90	.277	71.6	47.8	62.5	37.7
89	.278	71.8	48.0	62.7	37.8
88	.279	72.1	48.2	62.9	37.9
87	.281	72.6	48.5	63.4	38.2
86	.282	72.9	48.7	63.6	38.4
85	.283	73.1	48.8	63.8	38.5
84	.285	73.6	49.2	64.3	38.8
83	.286	73.9	49.4	64.5	38.9
82	.287	74.2	49.5	64.7	39.0
81	.289	74.7	49.9	65.2	39.3
80	.290	74.9	50.1	65.4	39.4
79	.291	75.2	50.2	65.6	39.6
78	.293	75.7	50.6	66.1	39.8
77	.294	76.0	50.7	66.3	40.0
76	.296	76.5	51.1	66.7	40.3
75	.297	76.7	51.3	67.0	40.4
74	.299	77.3	51.6	67.4	40.7
73	.300	77.5	51.8	67.7	40.8
72	.301	77.8	52.0	67.9	40.9
71	.303	78.3	52.3	68.3	41.2
70	.304	78.6	52.5	68.6	41.3
69	.306	79.1	52.8	69.0	41.6
68	.307	79.3	53.0	69.2	41.8
67	.309	79.8	53.3	69.7	42.0
66	.311	80.4	53.7	70.1	42.3
65	.312	80.6	53.9	70.4	42.4
64	.314	81.1	54.2	70.8	42.7
63	.315	81.4	54.4	71.0	42.8
62	.317	81.9	54.7	71.5	43.1
61	.319	82.4	55.1	71.9	43.4
60	.320	82.7	55.2	72.2	43.5
59	.322	83.2	55.6	72.6	43.8
58	.324	83.7	55.9	73.1	44.1
57	.325	84.0	56.1	73.3	44.2
56	.329	85.0	56.8	74.2	44.7

D



## PSI Per Barrel Tables A - Oil

D

API Oil Gravity	Fluid Gradient psi/ft	PSI per Barrel			
		2 <sup>3</sup> / <sub>8</sub> 4.7 lb/ft EUE Tubing	2 <sup>7</sup> / <sub>8</sub> 6.5 lb/ft EUE Tubing	2 <sup>7</sup> / <sub>8</sub> 10.4 lb/ft IU Drill Pipe	3 <sup>1</sup> / <sub>2</sub> 13.3 lb/ft IU Drill Pipe
55	.329	85.0	56.8	74.2	44.7
54	.331	85.5	57.1	74.6	45.0
53	.332	85.8	57.3	74.9	45.2
52	.334	86.3	57.6	75.3	45.4
51	.336	86.8	58.0	75.8	45.7
50	.338	87.3	58.3	76.2	46.0
49	.340	87.9	58.7	76.7	46.2
48	.341	88.1	58.9	76.9	46.4
47	.344	88.9	59.4	77.6	46.8
46	.345	89.1	59.5	77.8	46.9
45	.348	89.9	60.1	78.5	47.3
44	.349	90.2	60.2	78.7	47.5
43	.351	90.7	60.6	79.2	47.7
42	.354	91.5	61.1	79.8	48.1
41	.355	91.7	61.3	80.1	48.3
40	.357	92.2	61.6	80.5	48.6
39	.359	92.8	62.0	81.0	48.8
38	.362	93.5	62.5	81.6	49.2
37	.364	94.1	62.8	82.1	49.5
36	.366	94.6	63.2	82.5	49.8
35	.368	95.1	63.5	83.0	50.0
34	.370	95.6	63.9	83.4	50.3
33	.373	96.4	64.4	84.1	50.7
32	.375	96.9	64.7	84.6	51.0
31	.377	97.4	65.1	85.0	51.3
30	.379	97.9	65.4	85.5	51.5
29	.382	98.7	65.9	86.1	52.0
28	.384	99.2	66.3	86.6	52.2
27	.387	100.0	66.8	87.3	52.6
26	.389	100.5	67.1	87.7	52.9
25	.392	101.3	67.7	88.4	53.3
24	.394	101.8	68.0	88.8	53.6
23	.397	102.6	68.5	89.5	54.0
22	.399	103.1	68.9	90.0	54.3
21	.402	103.9	69.4	90.7	54.7
20	.405	104.7	69.9	91.3	55.1
19	.408	105.4	70.4	92.0	55.5
18	.410	105.9	70.8	92.5	55.8
17	.413	106.7	71.3	93.1	56.2
16	.416	107.5	71.8	93.8	56.6
15	.418	108.0	72.1	94.3	56.8
14	.422	109.0	72.8	95.2	57.4
13	.425	109.8	73.4	95.8	57.8
12	.427	110.3	73.7	96.3	58.1
11	.430	111.1	74.2	97.0	58.5
10	.433	111.9	74.7	97.6	58.9

## PSI Per Barrel Tables B - Mud Weight

Mud Weight lb/gal	Fluid Gradient psi/ft	PSI per Barrel			
		2 <sup>3</sup> / <sub>8</sub> 4.7 lb/ft EUE Tubing	2 <sup>7</sup> / <sub>8</sub> 6.5 lb/ft EUE Tubing	2 <sup>7</sup> / <sub>8</sub> 10.4 lb/ft IU Drill Pipe	3 <sup>1</sup> / <sub>2</sub> 13.3 lb/ft IU Drill Pipe
8.34	.433	112.0	74.8	97.7	58.9
8.40	.436	112.8	75.3	98.4	59.3
8.50	.442	114.1	76.2	99.6	60.1
8.60	.447	115.4	77.1	100.7	60.8
8.70	.452	116.8	78.0	101.9	61.5
8.80	.457	118.1	78.9	103.1	62.2
8.90	.462	119.5	79.8	104.3	62.9
9.00	.468	120.8	80.7	105.4	63.6
9.10	.473	122.2	81.6	106.6	64.3
9.20	.478	123.5	82.5	107.8	65.0
9.30	.483	124.8	83.4	108.9	65.7
9.40	.488	126.2	84.3	110.1	66.4
9.50	.494	127.5	85.2	111.3	67.1
9.60	.499	128.9	86.1	112.5	67.8
9.70	.504	130.2	87.0	113.6	68.5
9.80	.509	131.6	87.9	114.8	69.2
9.90	.514	132.9	88.8	116.0	69.9
10.00	.520	134.2	89.7	117.1	70.7
10.10	.525	135.6	90.6	118.3	71.4
10.20	.530	136.9	91.5	119.5	72.1
10.30	.535	138.3	92.4	120.4	72.7
10.40	.540	139.6	93.3	121.8	73.5
10.50	.545	141.0	94.1	123.0	74.2
10.60	.551	142.3	95.0	124.2	74.9
10.70	.556	143.6	95.9	125.3	75.6
10.80	.561	145.0	96.8	126.5	76.3
10.90	.566	146.3	97.7	127.7	77.0
11.00	.571	147.7	98.6	128.9	77.7
11.10	.577	149.0	99.5	130.0	78.4
11.20	.582	150.3	100.4	131.2	79.1
11.30	.587	151.7	101.3	132.4	79.8
11.40	.592	153.0	102.2	133.5	80.5
11.50	.597	154.4	103.1	134.7	81.2
11.60	.603	155.7	104.0	135.9	82.0
11.70	.608	157.1	104.9	137.1	82.7
11.80	.613	158.4	105.8	138.2	83.4
11.90	.618	159.7	106.7	139.4	84.1
12.00	.623	161.1	107.6	140.6	84.8
12.10	.629	162.4	108.5	141.7	85.5
12.20	.634	163.8	109.4	142.9	86.2
12.30	.639	165.1	110.3	144.1	86.9
12.40	.644	166.5	111.2	145.3	87.6
12.50	.649	167.8	112.1	146.4	88.3
12.60	.655	169.1	113.0	147.6	89.0
12.70	.660	170.5	113.9	148.8	89.7
12.80	.665	171.8	114.8	149.9	90.4

D

## PSI Per Barrel Tables B - Mud Weight

D

Mud Weight lb/gal	Fluid Gradient psi/ft	PSI per Barrel			
		2 <sup>3</sup> / <sub>8</sub> 4.7 lb/ft EUE Tubing	2 <sup>7</sup> / <sub>8</sub> 6.5 lb/ft EUE Tubing	2 <sup>7</sup> / <sub>8</sub> 10.4 lb/ft IU Drill Pipe	3 <sup>1</sup> / <sub>2</sub> 13.3 lb/ft IU Drill Pipe
12.90	.670	173.2	115.7	151.1	91.1
13.00	.675	174.5	116.6	152.3	91.8
13.10	.681	175.9	117.5	153.5	92.6
13.20	.686	177.2	118.4	154.6	93.3
13.30	.691	178.5	119.3	155.8	94.0
13.40	.696	179.9	120.2	157.0	94.7
13.50	.701	181.2	121.0	158.1	95.4
13.60	.707	182.6	121.9	159.3	96.1
13.70	.712	183.9	122.8	160.5	96.8
13.80	.717	185.2	123.7	161.7	97.5
13.90	.722	186.6	124.6	162.8	98.2
14.00	.727	187.9	125.5	164.0	98.9
14.10	.732	189.3	126.4	165.2	99.6
14.20	.738	190.6	127.3	166.3	100.3
14.30	.743	192.0	128.2	167.5	101.0
14.40	.748	193.3	129.1	168.7	101.7
14.50	.753	194.6	130.0	169.9	102.4
14.60	.758	196.0	130.9	171.0	103.2
14.70	.764	197.3	131.8	172.2	103.9
14.80	.769	198.7	132.7	173.4	104.6
14.90	.774	200.0	133.6	174.5	105.3
15.00	.779	201.4	134.5	175.7	106.0
15.10	.784	202.7	135.4	176.9	106.7
15.20	.790	204.0	136.3	178.1	107.4
15.30	.795	205.4	137.2	179.2	108.1
15.40	.800	206.7	138.1	180.4	108.8
15.50	.805	208.1	139.0	181.6	109.5
15.60	.810	209.4	139.9	183.7	110.2
15.70	.816	210.8	140.8	183.9	110.9
15.80	.821	212.1	141.7	185.1	111.6
15.90	.826	213.4	142.6	186.3	112.3
16.00	.831	214.8	143.5	487.4	113.0
16.10	.836	216.1	144.4	188.6	113.7
16.20	.842	217.5	145.3	189.8	114.5
16.30	.847	218.8	146.2	191.0	115.2
16.40	.852	220.2	147.1	192.1	115.9
16.50	.857	221.5	147.9	193.3	116.6
16.60	.862	222.8	148.8	194.5	117.3
16.70	.868	224.2	149.7	195.6	118.0
16.80	.873	225.5	150.6	196.8	118.7
16.90	.878	226.9	151.5	198.0	119.4
17.00	.883	228.2	152.4	199.2	120.1
17.10	.888	229.5	153.3	200.3	120.8
17.20	.894	230.9	154.2	201.5	121.5
17.30	.899	232.2	155.1	202.7	122.2
17.40	.904	233.6	156.0	203.8	122.9

## PSI Per Barrel Tables B - Mud Weight

Mud Weight lb/gal	Fluid Gradient psi/ft	PSI per Barrel			
		2 <sup>3</sup> / <sub>8</sub> 4.7 lb/ft EUE Tubing	2 <sup>7</sup> / <sub>8</sub> 6.5 lb/ft EUE Tubing	2 <sup>7</sup> / <sub>8</sub> 10.4 lb/ft IU Drill Pipe	3 <sup>1</sup> / <sub>2</sub> 13.3 lb/ft IU Drill Pipe
17.50	.909	234.9	156.9	205.0	123.6
17.60	.914	236.3	157.8	206.2	124.3
17.70	.920	237.6	158.7	207.4	125.1
17.80	.925	238.9	159.6	208.5	125.8
17.90	.930	240.3	160.5	209.7	126.5
18.00	.935	241.6	161.4	210.9	127.2
18.10	.940	243.0	162.3	212.0	127.9
18.20	.945	244.3	163.2	213.2	128.6
18.30	.951	245.7	164.1	214.4	129.3
18.40	.956	247.0	165.0	215.6	130.0
18.50	.961	248.3	165.9	216.7	130.7
18.60	.966	249.7	166.8	217.9	131.4
18.70	.971	251.0	167.7	219.1	132.1
18.80	.977	252.4	168.6	220.2	132.8
18.90	.982	253.7	169.5	221.4	133.5
19.00	.987	255.1	170.4	222.6	134.2
19.10	.992	256.4	171.3	223.8	134.9
19.20	.997	257.7	172.2	224.9	135.7
19.30	1.003	259.1	173.1	226.1	136.4
19.40	1.008	260.4	174.0	227.3	137.1
19.50	1.012	261.8	174.8	228.4	137.8
19.60	1.018	263.1	175.7	229.6	138.5
19.70	1.023	264.5	176.6	230.8	139.2
19.80	1.029	265.8	177.5	232.0	139.9
19.90	1.034	267.1	178.4	233.1	140.6
20.00	1.039	268.5	179.3	234.3	141.3

D



# Oil-Water Mixture Gradient Table

\*Water Component

Fluid Weight		% Water Cut																			Water Component Gradient (psi/ft)		
		0	5	10	15	20	25	30	35	40	45	50	55	60	65	70	75	80	85	90		95	100
Lb/Gal	Lb/FT <sup>3</sup>	0	.022	.043	.065	.087	.108	.130	.152	.173	.195	.217	.239	.260	.282	.304	.326	.347	.369	.390	.412	.434	
8.34	62.37	0	.022	.044	.066	.087	.109	.131	.153	.175	.197	.218	.240	.262	.284	.306	.328	.349	.371	.393	.415	.437	
8.40	62.84	0	.022	.044	.066	.088	.111	.133	.155	.177	.199	.221	.243	.265	.287	.309	.332	.354	.376	.398	.420	.442	
8.50	63.58	0	.022	.045	.067	.089	.112	.134	.157	.179	.201	.224	.246	.268	.291	.313	.335	.358	.380	.402	.425	.447	
8.60	64.33	0	.023	.045	.069	.090	.113	.136	.158	.181	.204	.226	.249	.271	.294	.317	.339	.362	.385	.407	.430	.452	
8.70	65.08	0	.023	.046	.069	.092	.114	.137	.160	.183	.206	.229	.252	.275	.297	.320	.343	.366	.389	.412	.435	.458	
8.80	65.83	0	.023	.046	.069	.093	.116	.139	.162	.185	.208	.231	.255	.278	.301	.324	.347	.370	.393	.417	.440	.463	
8.90	66.58	0	.023	.047	.070	.094	.117	.140	.164	.187	.211	.234	.257	.281	.304	.328	.351	.374	.398	.421	.445	.468	
9.00	67.32	0	.024	.047	.071	.095	.118	.142	.166	.189	.213	.237	.260	.284	.308	.331	.355	.379	.402	.426	.450	.473	
9.10	68.07	0	.024	.048	.072	.096	.120	.143	.167	.191	.215	.239	.263	.287	.311	.335	.359	.383	.407	.431	.454	.478	
9.20	68.82	0	.024	.048	.073	.097	.121	.145	.169	.193	.218	.242	.266	.290	.314	.339	.363	.387	.411	.435	.459	.484	
9.30	69.57	0	.024	.049	.073	.098	.122	.147	.171	.196	.220	.244	.269	.293	.318	.342	.367	.391	.415	.440	.464	.489	
9.40	70.32	0	.025	.049	.074	.099	.124	.148	.173	.198	.222	.247	.272	.296	.321	.346	.371	.395	.420	.445	.469	.494	
9.50	71.06	0	.025	.050	.075	.100	.125	.150	.175	.200	.225	.250	.275	.300	.324	.349	.374	.399	.424	.449	.474	.499	
9.60	71.81	0	.025	.050	.076	.101	.126	.151	.177	.202	.227	.252	.277	.303	.329	.353	.378	.404	.429	.454	.479	.504	
9.70	72.56	0	.025	.051	.076	.102	.127	.153	.178	.204	.229	.255	.280	.306	.331	.357	.382	.408	.433	.459	.484	.510	
9.80	73.31	0	.026	.051	.077	.103	.129	.154	.180	.206	.232	.257	.283	.309	.335	.360	.386	.412	.438	.463	.489	.515	
9.90	74.06	0	.026	.052	.078	.104	.130	.156	.182	.208	.234	.260	.286	.312	.338	.364	.390	.416	.442	.468	.494	.520	
10.00	74.81	0	.026	.053	.079	.105	.131	.158	.184	.210	.236	.263	.289	.315	.341	.368	.394	.420	.446	.473	.499	.525	
10.10	75.55	0	.027	.053	.080	.106	.133	.159	.186	.212	.239	.265	.292	.318	.345	.371	.399	.424	.451	.477	.504	.530	
10.20	76.30	0	.027	.054	.080	.107	.134	.161	.187	.214	.241	.268	.295	.321	.348	.375	.402	.428	.455	.482	.509	.536	
10.30	77.05	0	.027	.054	.081	.108	.135	.162	.189	.216	.243	.270	.297	.324	.352	.379	.406	.433	.460	.487	.514	.541	
10.40	77.80	0	.027	.055	.082	.109	.137	.164	.191	.218	.246	.273	.300	.328	.355	.382	.410	.437	.464	.491	.519	.546	
10.50	78.55																						

\*To find the total oil-water mixture pressure gradient, the water component gradient must be added to the oil component gradient.

# Oil-Water Mixture Gradient Table

\*Oil Component

Oil API Gravity	% Water Cut																				
	0	5	10	15	20	25	30	35	40	45	50	55	60	65	70	75	80	85	90	95	100
10	.433	.412	.390	.368	.347	.325	.303	.282	.260	.238	.217	.195	.173	.152	.130	.108	.087	.065	.043	.022	0
14	.422	.401	.379	.358	.337	.316	.295	.274	.253	.232	.211	.190	.169	.148	.126	.105	.084	.063	.042	.021	0
18	.410	.390	.369	.349	.328	.308	.287	.267	.246	.226	.205	.185	.164	.144	.123	.103	.082	.062	.041	.021	0
22	.400	.380	.360	.340	.320	.300	.280	.260	.240	.220	.200	.180	.160	.140	.120	.100	.080	.060	.040	.020	0
26	.389	.370	.351	.331	.312	.292	.273	.253	.234	.214	.195	.175	.156	.136	.117	.097	.078	.058	.039	.019	0
30	.380	.361	.342	.323	.304	.285	.266	.247	.228	.209	.190	.171	.152	.133	.114	.095	.076	.057	.038	.019	0
34	.371	.352	.336	.315	.297	.278	.259	.241	.222	.204	.185	.167	.148	.130	.111	.093	.074	.056	.037	.019	0
38	.362	.344	.326	.308	.290	.271	.253	.235	.217	.199	.181	.163	.145	.127	.109	.090	.072	.054	.036	.018	0
42	.354	.336	.318	.301	.283	.265	.247	.230	.212	.194	.177	.159	.141	.124	.106	.088	.071	.053	.035	.018	0
46	.346	.328	.311	.294	.276	.259	.242	.225	.207	.190	.173	.156	.138	.121	.104	.086	.069	.052	.035	.017	0
50	.338	.321	.304	.287	.270	.253	.237	.220	.203	.186	.169	.152	.135	.118	.101	.084	.068	.051	.034	.017	0
54	.331	.314	.298	.281	.265	.248	.231	.215	.198	.182	.165	.149	.132	.116	.099	.083	.066	.050	.033	.017	0
58	.324	.308	.291	.275	.259	.243	.227	.210	.194	.178	.162	.146	.129	.113	.097	.081	.065	.049	.032	.016	0
62	.317	.301	.285	.269	.254	.238	.222	.206	.190	.174	.159	.143	.127	.111	.095	.079	.063	.048	.032	.016	0
66	.311	.295	.280	.264	.248	.233	.217	.202	.186	.171	.155	.140	.124	.109	.093	.078	.062	.047	.031	.016	0
70	.304	.289	.274	.259	.244	.228	.213	.198	.183	.167	.152	.137	.122	.107	.091	.076	.061	.046	.030	.015	0
74	.299	.284	.269	.254	.239	.224	.209	.194	.179	.164	.149	.134	.119	.104	.090	.075	.060	.045	.030	.015	0
78	.293	.278	.264	.249	.234	.220	.205	.190	.176	.161	.146	.132	.117	.102	.088	.073	.059	.044	.029	.015	0
82	.287	.273	.259	.244	.230	.215	.201	.187	.172	.158	.144	.129	.115	.101	.086	.072	.057	.043	.029	.014	0
86	.282	.268	.254	.240	.226	.212	.197	.183	.169	.155	.141	.127	.113	.099	.085	.071	.056	.042	.028	.014	0
90	.277	.263	.249	.235	.222	.208	.194	.180	.166	.152	.138	.125	.111	.097	.083	.069	.055	.042	.028	.014	0
94	.272	.258	.245	.231	.218	.204	.190	.177	.163	.150	.136	.122	.109	.095	.082	.068	.054	.041	.027	.014	0
98	.267	.254	.241	.227	.214	.200	.187	.174	.160	.147	.134	.120	.107	.094	.080	.067	.053	.040	.027	.013	0

Oil Component Gradient (psi/ft)

\*To find the total oil-water mixture pressure gradient, the oil component gradient must be added to the water component gradient.



## Method of Calculating Time In Minutes to Pump Cementing Plug to Seat

- Step 1:** Calculate capacity of circulating path in barrels.
- Step 2:** Multiply circulating capacity by "Strokes per Barrel" at rated pump efficiency.
- Step3:** Multiply answer in Step 2 by "Minutes per Stroke".

D

BORE in.	STROKE in.	STROKES PER BARREL		
		95% Efficiency	90% Efficiency	85% Efficiency
3.50	10	106.15	112.05	118.64
4.00		81.27	85.78	90.83
4.50		64.21	67.78	71.77
5.00		52.01	54.90	58.13
5.00	12	43.34	45.75	48.44
5.50		35.82	37.81	40.04
6.00		30.10	31.77	33.64
6.25		27.74	29.28	31.00
6.50		25.65	27.07	28.66
6.75		23.78	25.10	26.58
7.00		22.11	23.34	24.72
7.25		20.62	21.76	23.04
7.50		19.26	20.33	21.53
7.75		18.04	19.04	20.16
5.00	14	37.15	39.22	41.52
5.50		30.70	32.41	34.32
6.00		25.80	27.23	28.84
6.25		23.78	25.10	26.57
6.50		21.98	23.20	24.57
6.75		20.39	21.52	22.78
7.00		18.95	20.01	21.18
7.25		17.67	18.65	19.75
7.50		16.51	17.43	18.45
7.75		15.46	16.32	17.28

Method of Calculating Time In Minutes  
to Pump Cementing Plug to Seat

BORE in.	STROKE in.	STROKES PER BARREL		
		95% Efficiency	90% Efficiency	85% Efficiency
5.00	16	32.51	34.31	36.33
5.50		26.87	28.36	30.03
6.00		22.57	23.83	25.23
6.25		20.81	21.96	23.25
6.50		19.24	20.30	21.50
6.75		17.84	18.83	19.94
7.00		16.59	17.51	18.54
7.25		15.46	16.32	17.28
7.50		14.45	15.25	16.15
7.75		13.53	14.28	15.12
5.00	18	28.90	30.50	32.30
5.50		23.88	25.21	26.69
6.00		20.07	21.18	22.43
6.25		18.49	19.52	20.67
6.50		17.10	18.05	19.11
6.75		15.86	16.74	17.72
7.00		14.74	15.56	16.48
7.25		13.74	4.51	15.36
7.50		12.84	13.56	14.35
7.75		12.03	12.70	13.44
6.50	20	15.39	16.24	17.20
6.75		14.27	15.06	15.95
7.00		13.27	14.01	14.83
7.25		12.37	13.06	13.82
7.50		11.56	12.20	12.92
7.75		10.82	11.43	12.10
6.75	24	11.89	12.55	12.29
7.00		11.06	11.67	12.36
7.25		10.31	10.88	11.52
7.50		9.63	10.17	10.77
7.75		9.02	9.52	10.08
8.00		8.47	8.94	9.46

D



**D**





## Tubing Weight Factors $W_s$ , $W_i$ and $W_o$

Tubing Size O.D. in.	Tubing Weight lbs/ft	$W_s$ lbs/in	Fluid Weight (lbs/gal)																	
			$W_i$ and $W_o$ (lbs/in.)																	
			$W_i$	$W_o$	$W_i$	$W_o$	$W_i$	$W_o$	$W_i$	$W_o$	$W_i$	$W_o$	$W_i$	$W_o$	$W_i$	$W_o$	$W_i$	$W_o$	$W_i$	$W_o$
1.050	1.200	.100	.014	.023	.016	.026	.017	.028	.019	.030	.020	.032	.021	.034	.022	.036	.023	.038	.024	.039
1.315	1.800	.150	.022	.035	.026	.041	.028	.044	.030	.047	.032	.050	.034	.053	.036	.056	.037	.059	.039	.062
1.660	2.400	.200	.039	.056	.045	.066	.049	.070	.052	.075	.055	.080	.058	.084	.062	.089	.065	.094	.068	.098
1.900	2.900	.242	.053	.074	.062	.086	.066	.092	.071	.098	.075	.104	.079	.111	.084	.117	.088	.123	.093	.129
2.063	3.250	.271	.063	.087	.073	.101	.078	.109	.083	.116	.089	.123	.094	.130	.099	.138	.104	.144	.109	.152
2.375	4.700	.392	.081	.115	.095	.134	.102	.144	.108	.153	.115	.163	.122	.173	.129	.182	.135	.192	.142	.201
2.875	6.500	.542	.122	.169	.142	.197	.152	.211	.162	.225	.172	.239	.182	.253	.193	.267	.203	.281	.213	.295
3.500	9.200	.767	.183	.250	.213	.292	.228	.312	.244	.333	.259	.354	.274	.375	.289	.396	.304	.417	.320	.437
4.000	11.000	.917	.247	.326	.288	.381	.308	.408	.329	.435	.349	.462	.370	.490	.390	.517	.411	.544	.431	.571
4.500	12.750	1.063	.320	.413	.373	.482	.400	.516	.426	.551	.453	.585	.479	.620	.506	.654	.533	.689	.559	.723

Tubing Size O.D. in.	Tubing Weight lbs/ft	$W_s$ lbs/in	Fluid Weight (lbs/gal)																	
			$W_i$ and $W_o$ (lbs/in.)																	
			$W_i$	$W_o$	$W_i$	$W_o$	$W_i$	$W_o$	$W_i$	$W_o$	$W_i$	$W_o$	$W_i$	$W_o$	$W_i$	$W_o$	$W_i$	$W_o$	$W_i$	$W_o$
1.050	1.200	.100	.025	.041	.028	.045	.030	.049	.032	.053	.035	.056	.037	.060	.039	.064	.042	.068	.044	.071
1.315	1.800	.150	.041	.065	.045	.071	.049	.076	.052	.082	.056	.088	.060	.094	.064	.100	.067	.106	.071	.112
1.660	2.400	.200	.071	.103	.078	.112	.084	.122	.091	.131	.097	.141	.104	.150	.110	.159	.117	.169	.123	.178
1.900	2.900	.242	.097	.135	.106	.147	.115	.160	.123	.172	.132	.184	.141	.196	.150	.209	.159	.221	.167	.233
2.063	3.250	.271	.115	.159	.125	.174	.136	.188	.146	.203	.156	.217	.167	.232	.177	.246	.188	.261	.198	.275
2.375	4.700	.392	.149	.211	.162	.230	.176	.249	.189	.269	.203	.288	.217	.307	.230	.326	.244	.345	.257	.364
2.875	6.500	.542	.223	.309	.243	.337	.263	.365	.284	.393	.304	.422	.324	.450	.344	.478	.365	.506	.385	.534
3.500	9.200	.767	.335	.458	.365	.500	.396	.541	.426	.583	.457	.625	.487	.666	.517	.708	.548	.750	.578	.791
4.000	11.000	.917	.452	.598	.493	.653	.534	.707	.575	.762	.616	.816	.657	.870	.698	.925	.739	.979	.781	1.034
4.500	12.750	1.063	.586	.757	.639	.826	.692	.895	.746	.964	.799	1.033	.852	1.102	.906	1.170	.959	1.239	1.012	1.308



## BALLOONING FORCE

### \*Annulus Pressure Component

Tubing will **lengthen** due to an **increase** in average annular pressure ( $+\Delta P_{Oa}$ ) resulting in a **down** force  $\downarrow$ . Tubing will **shorten** due to a **decrease** in average annular pressure ( $-\Delta P_{Oa}$ ) resulting in an **up** force  $\uparrow$ .

\*The result obtained using the graph **must** be combined with the Tubing Pressure Component in order to obtain the total ballooning effect.

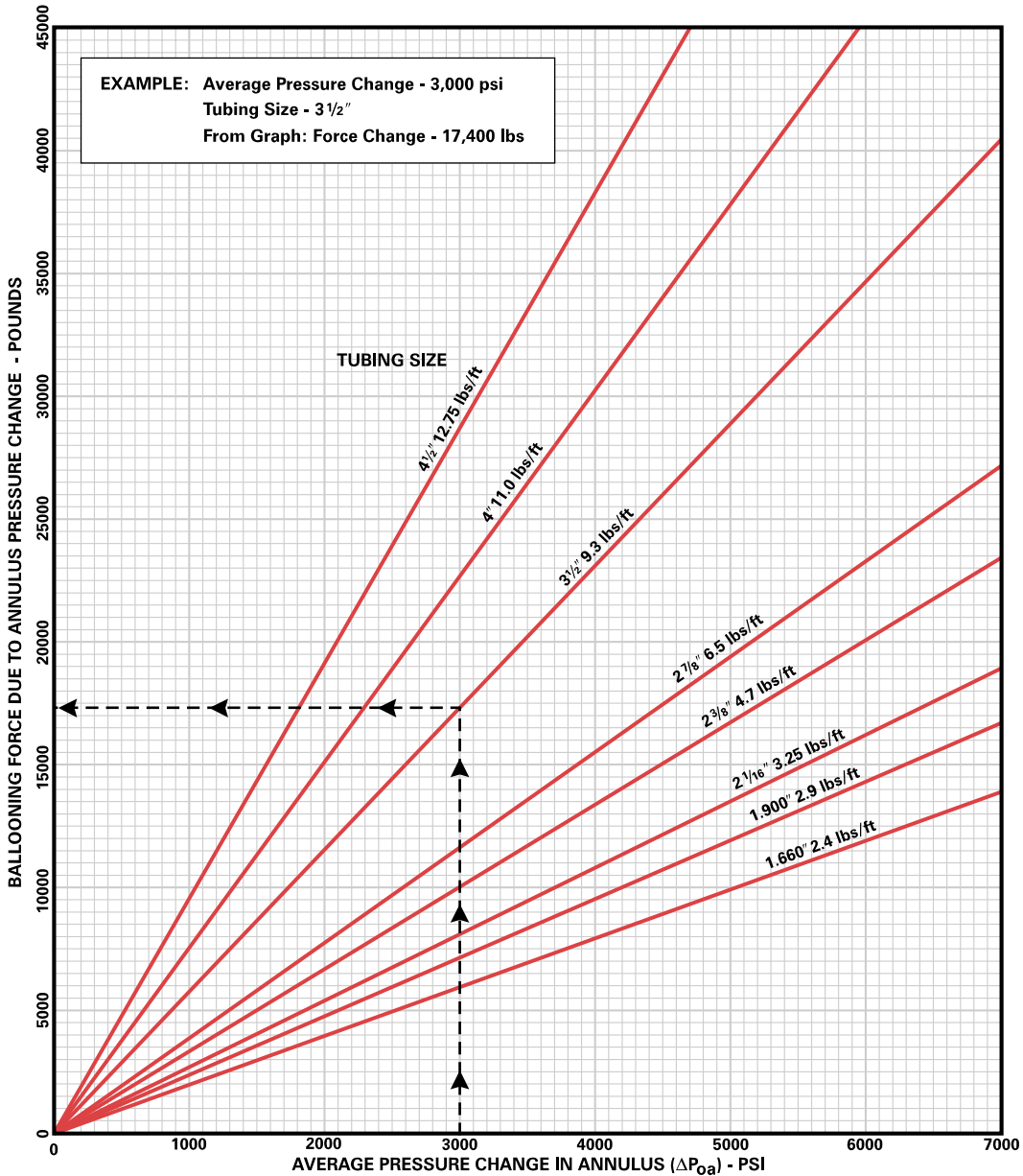

## BALLOONING FORCE \*Tubing Pressure Component

Tubing will **lengthen** due to an **decrease** in average tubing pressure ( $-\Delta P_a$ ) resulting in a **down** force  $\downarrow$ .  
 Tubing will **shorten** due to an **increase** in average tubing pressure ( $+\Delta P_a$ ) resulting in an **up** force  $\uparrow$ .

\*The result obtained using the graph **must** be combined with the Annulus Pressure Component in order to obtain the total ballooning effect.

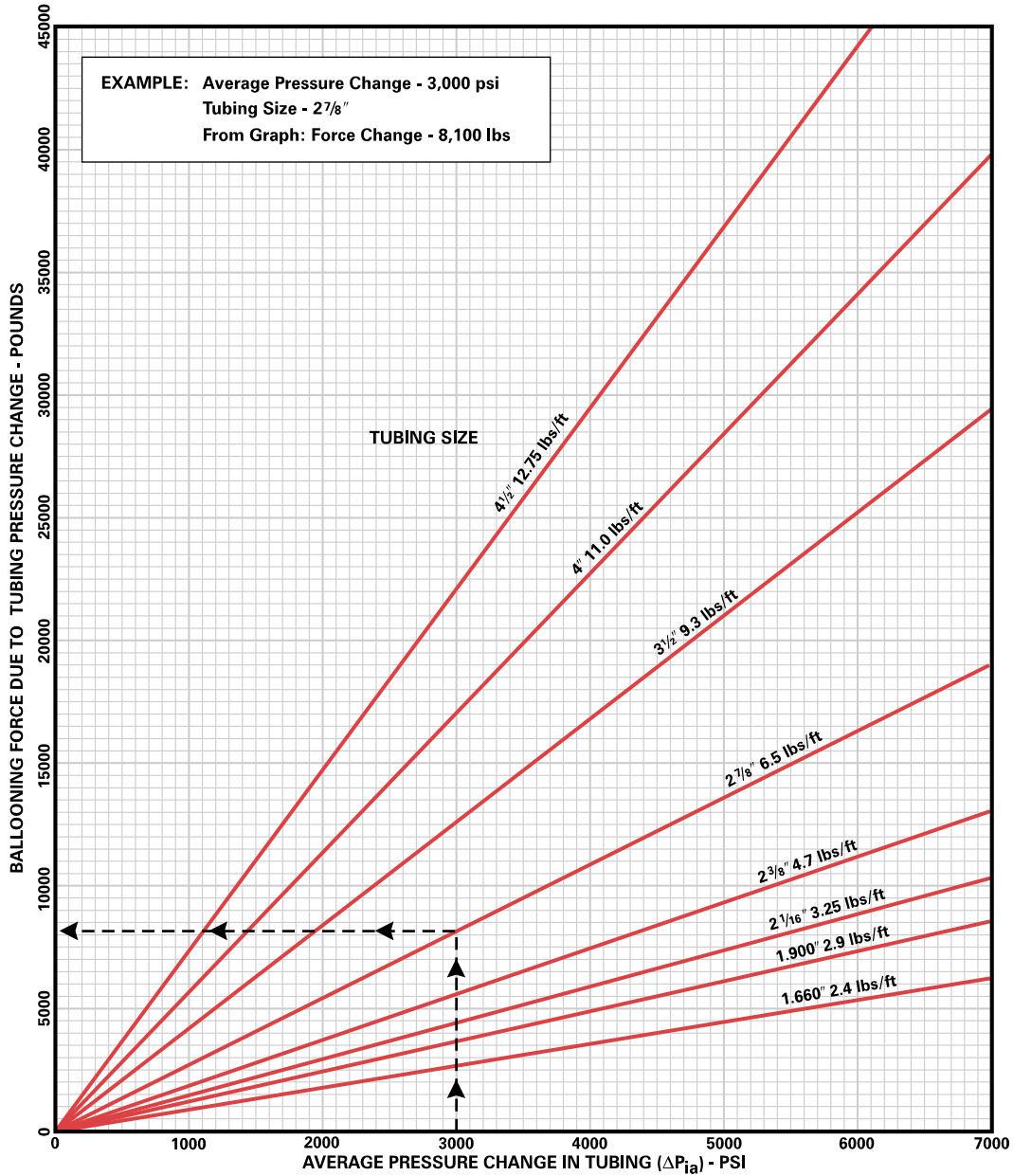

## CHANGE IN TUBING LENGTH DUE TO CHANGE IN AVERAGE TUBING TEMPERATURE

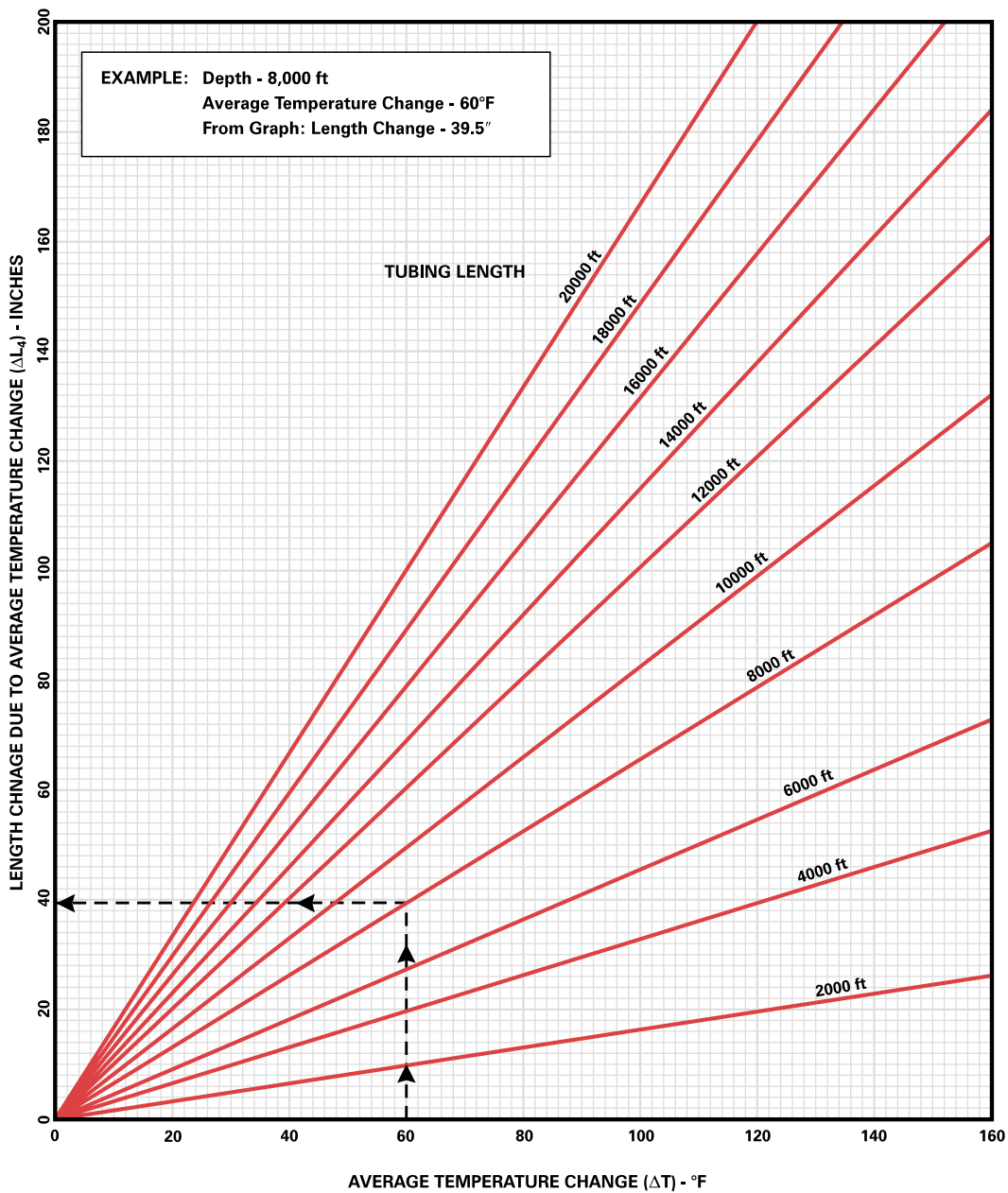

## CHANGE IN TUBING FORCE DUE TO CHANGE IN AVERAGE TUBING TEMPERATURE

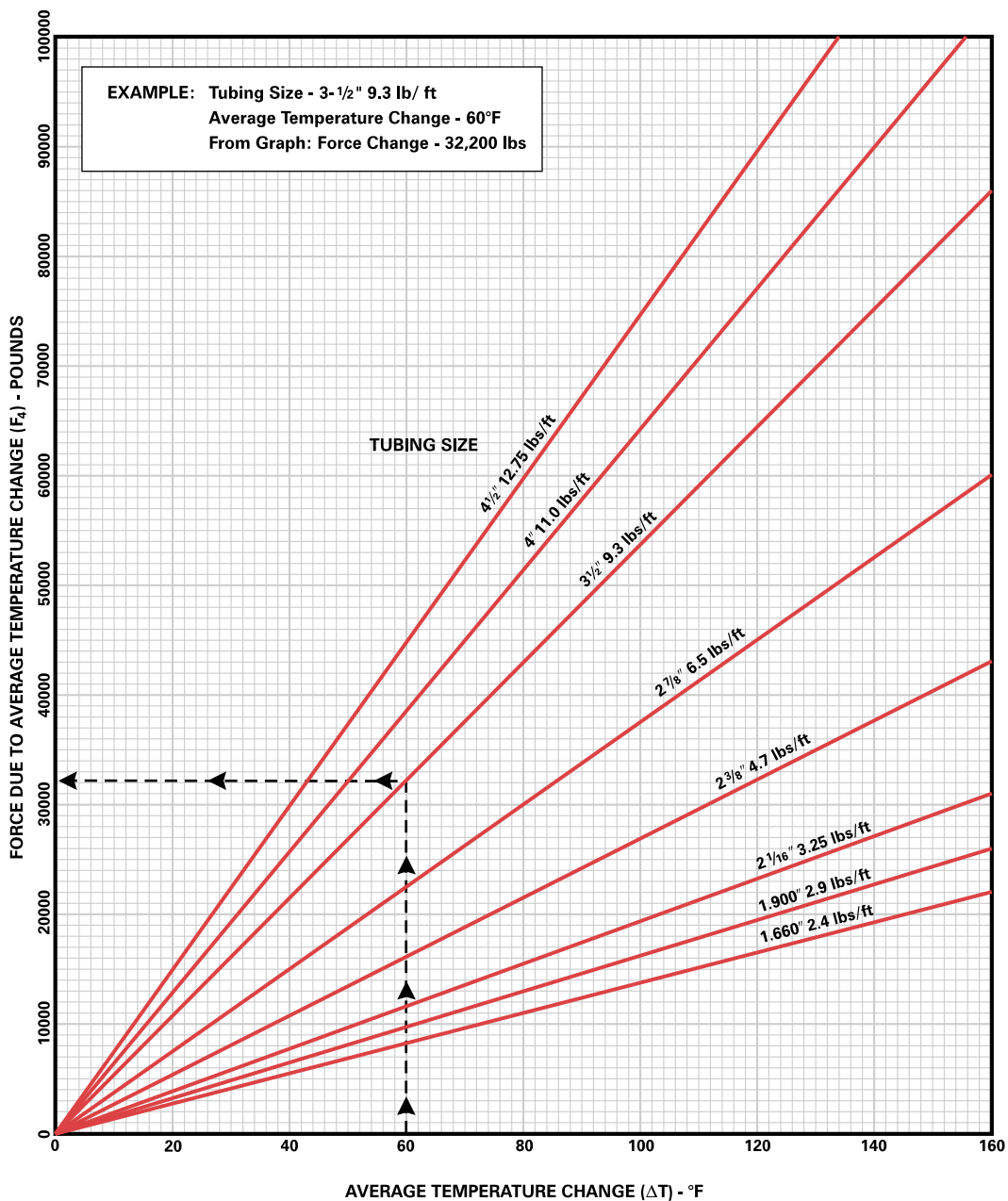









# SLACKOFF CHART - 1.660" TUBING

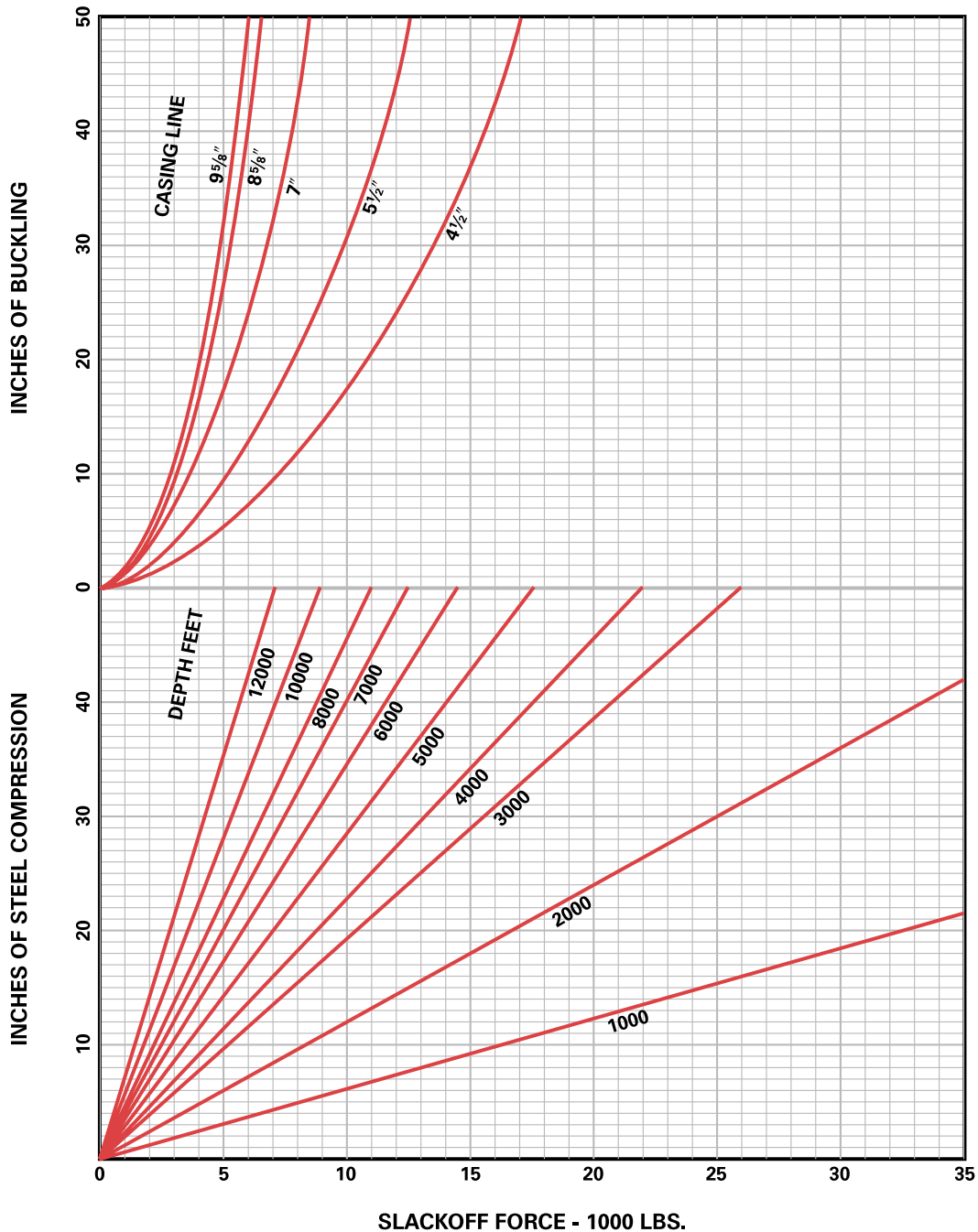

# SLACKOFF CHART - 1.900" TUBING

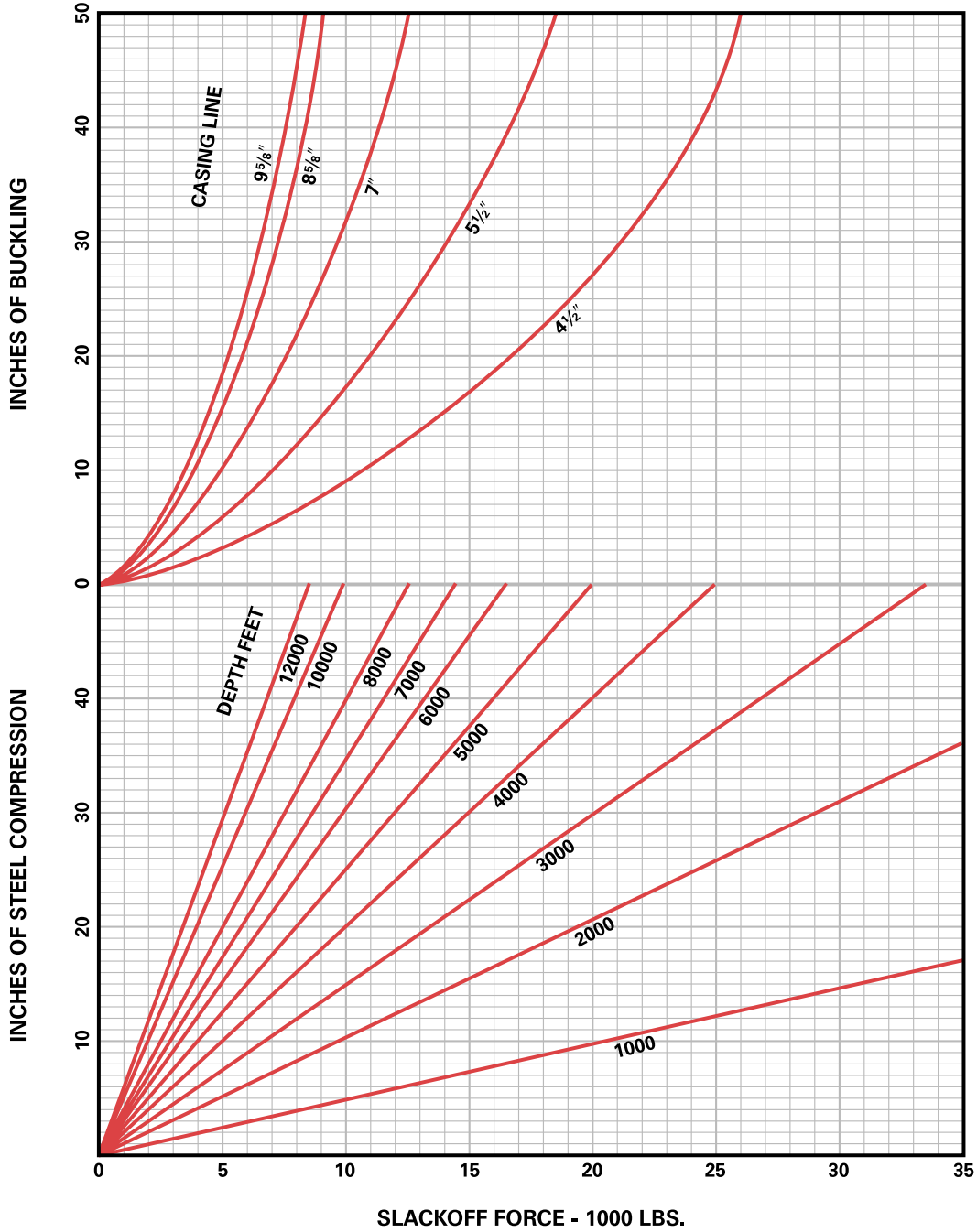

# SLACKOFF CHART - 2 1/16" TUBING

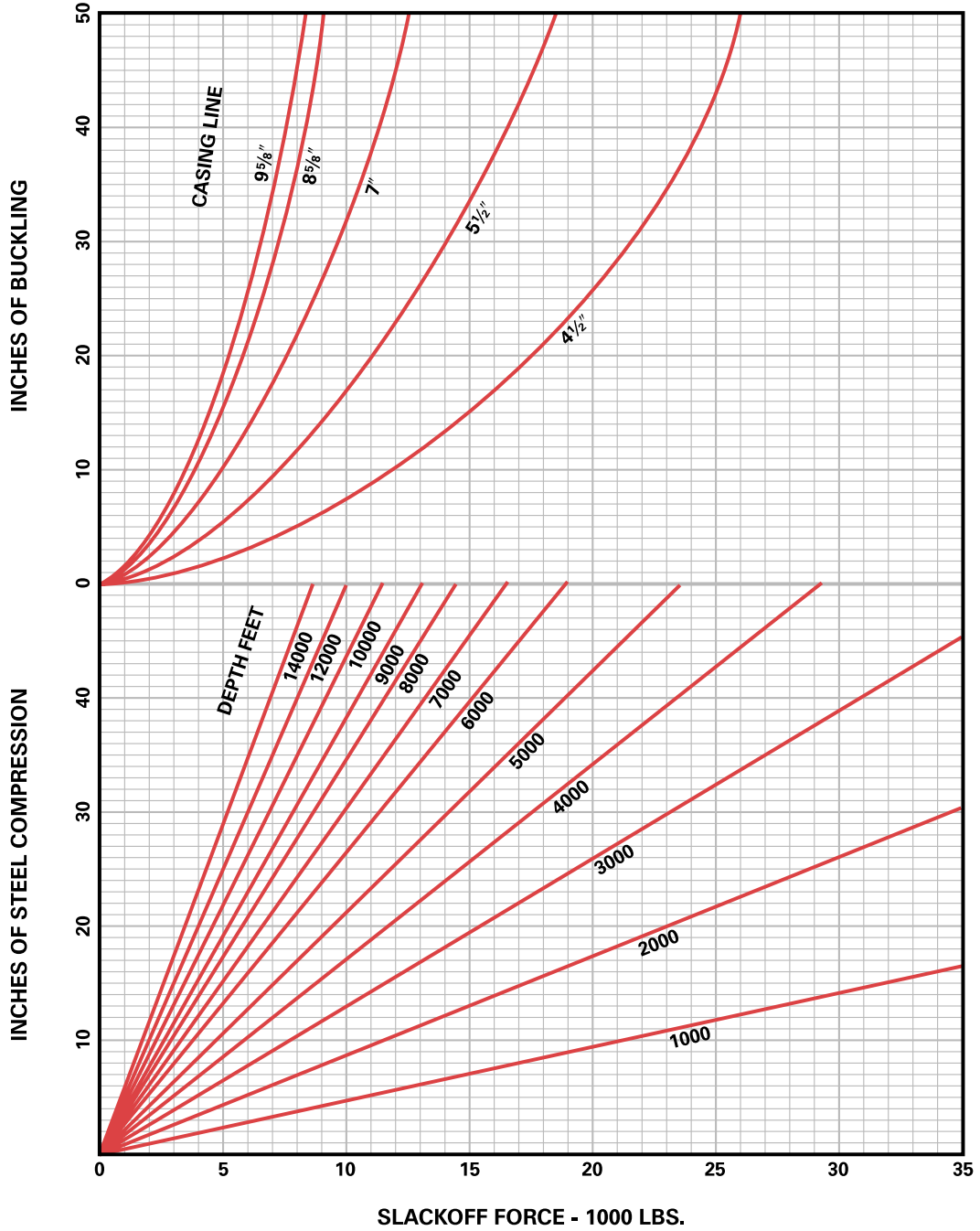

# SLACKOFF CHART - 2 3/8" TUBING

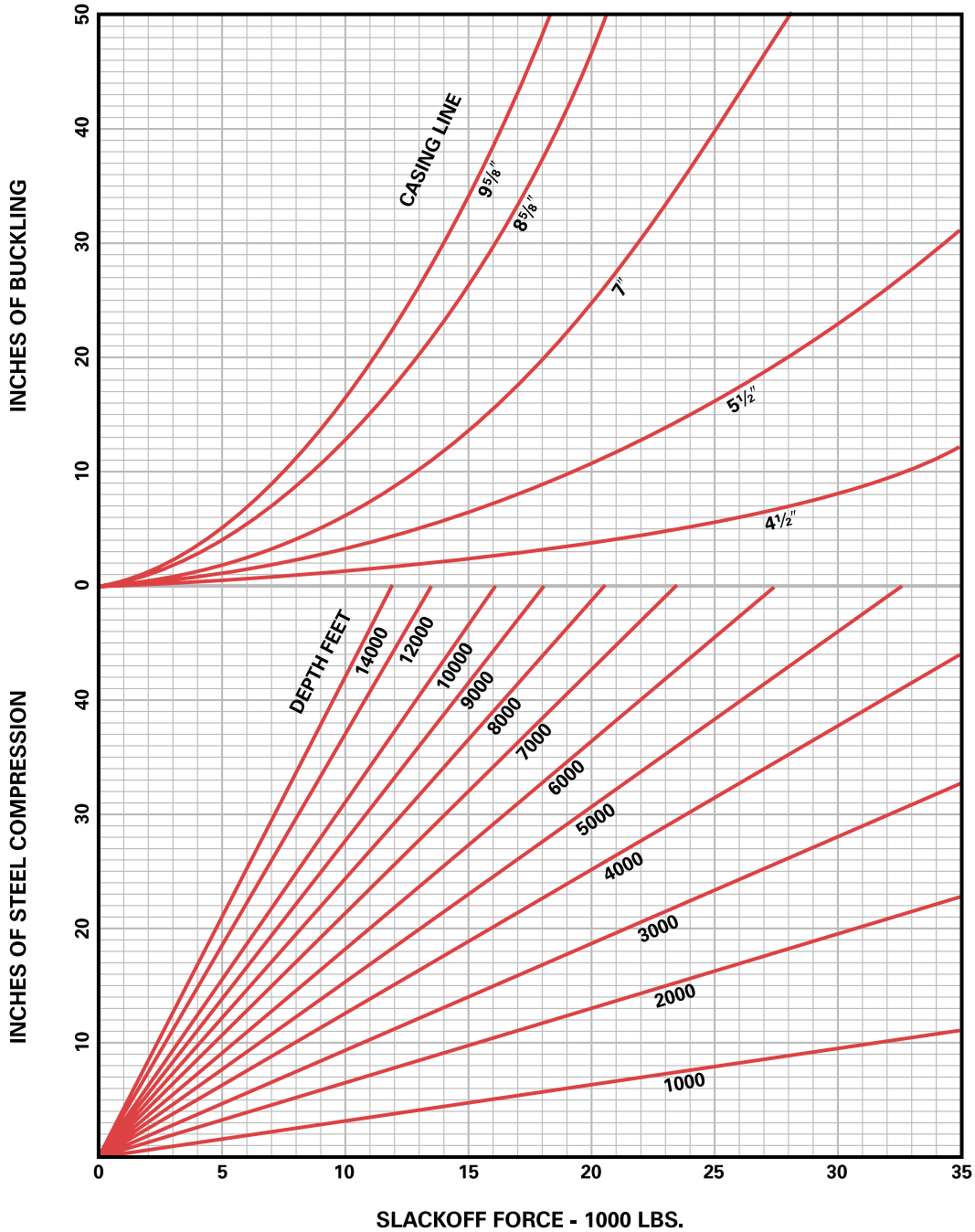

# SLACKOFF CHART - 2 7/8" TUBING

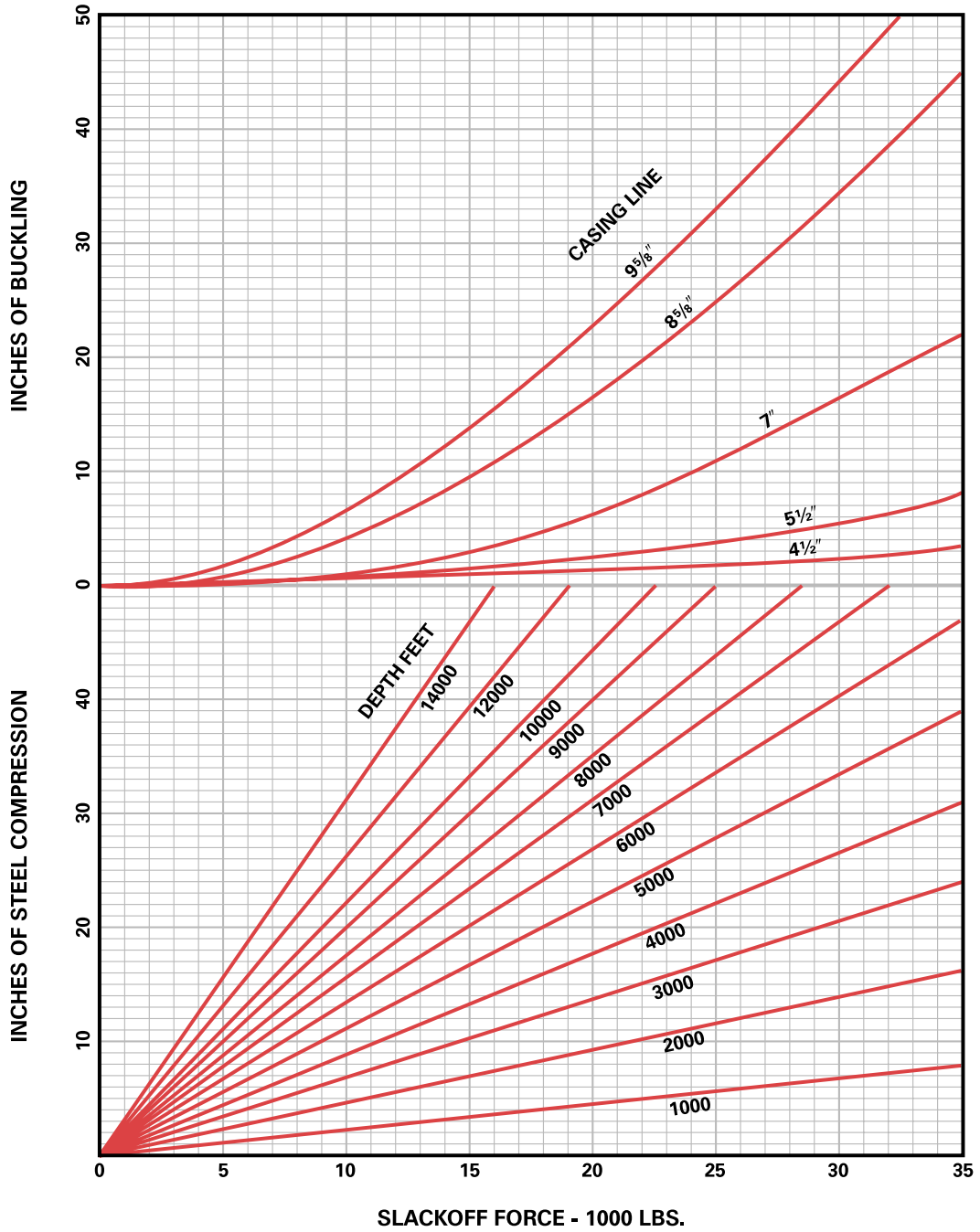



# SLACKOFF CHART - 3½" TUBING

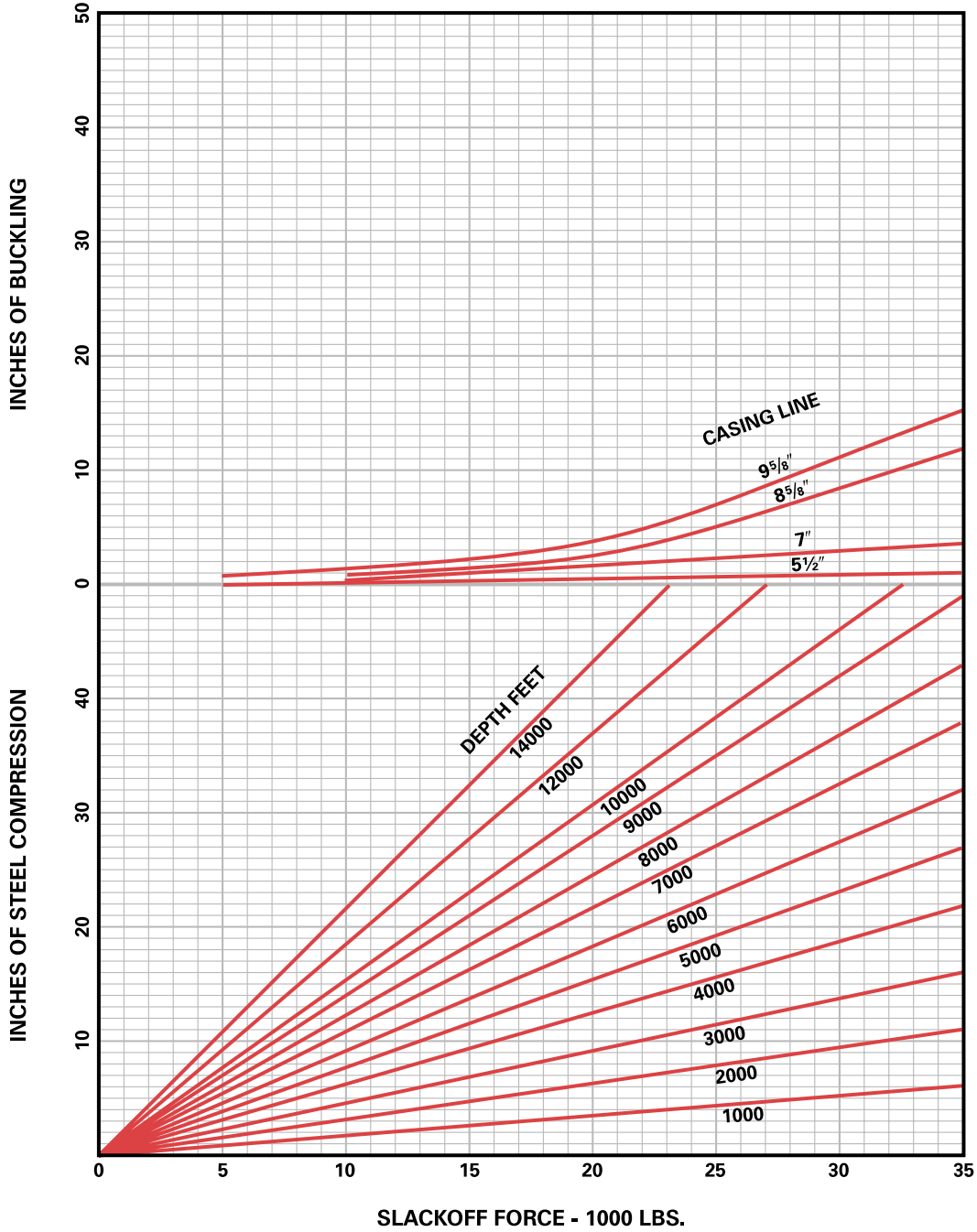

# SLACKOFF CHART - 4" TUBING

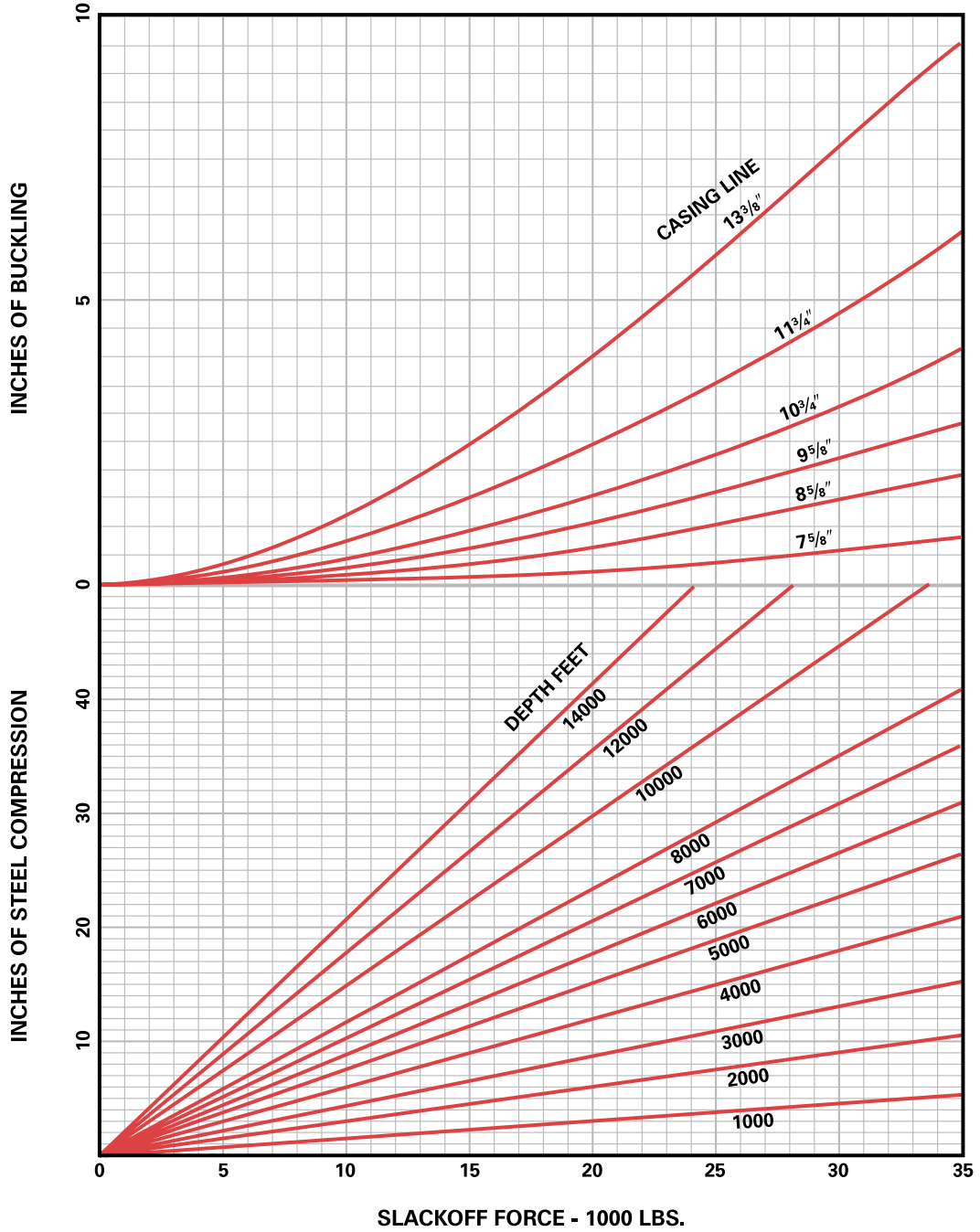

# SLACKOFF CHART - 4½" TUBING

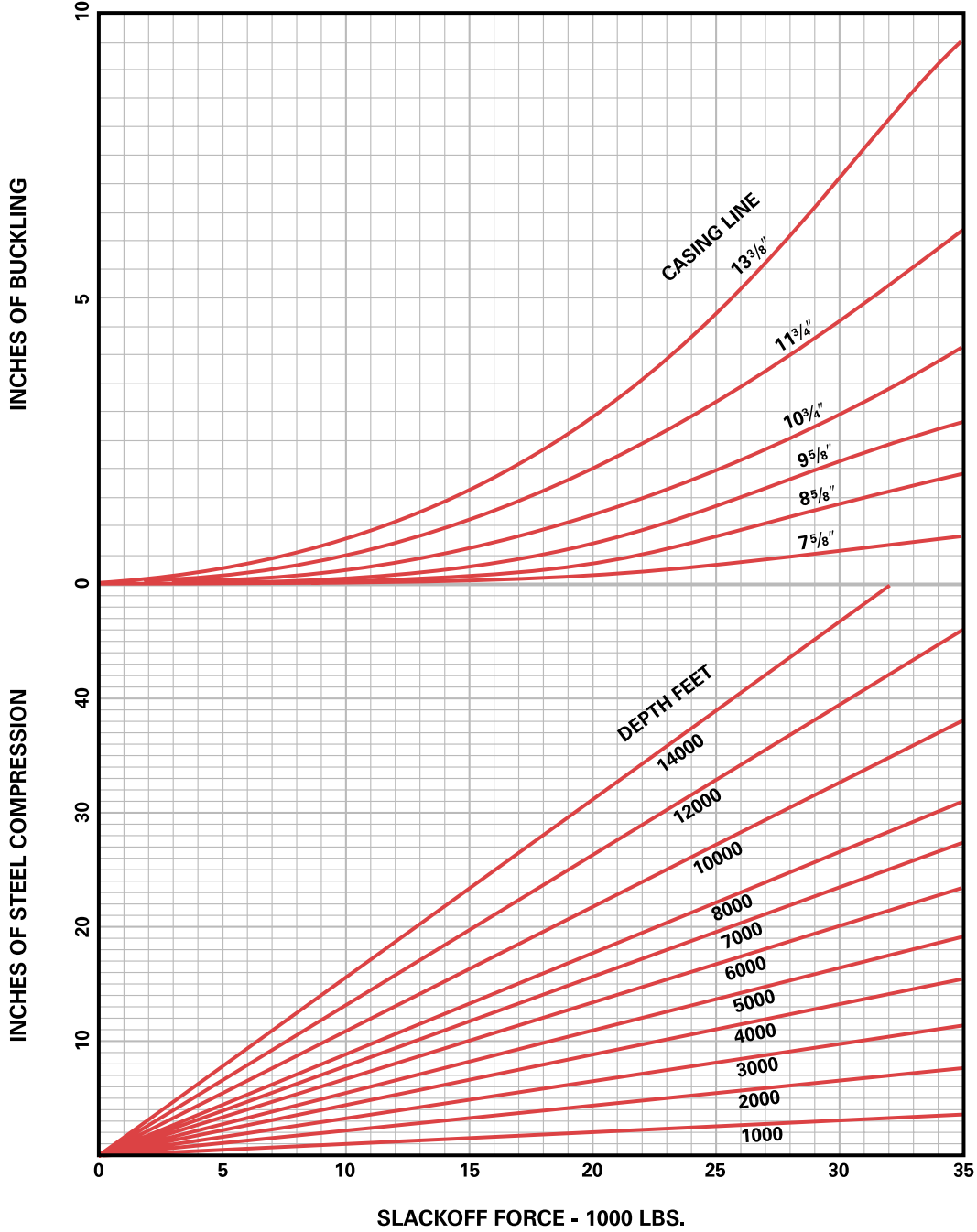

### Tubing Stretch Chart for 1.660" O.D. 2.4 #/Ft. E.U. or N.U. A.P.I. Tubing

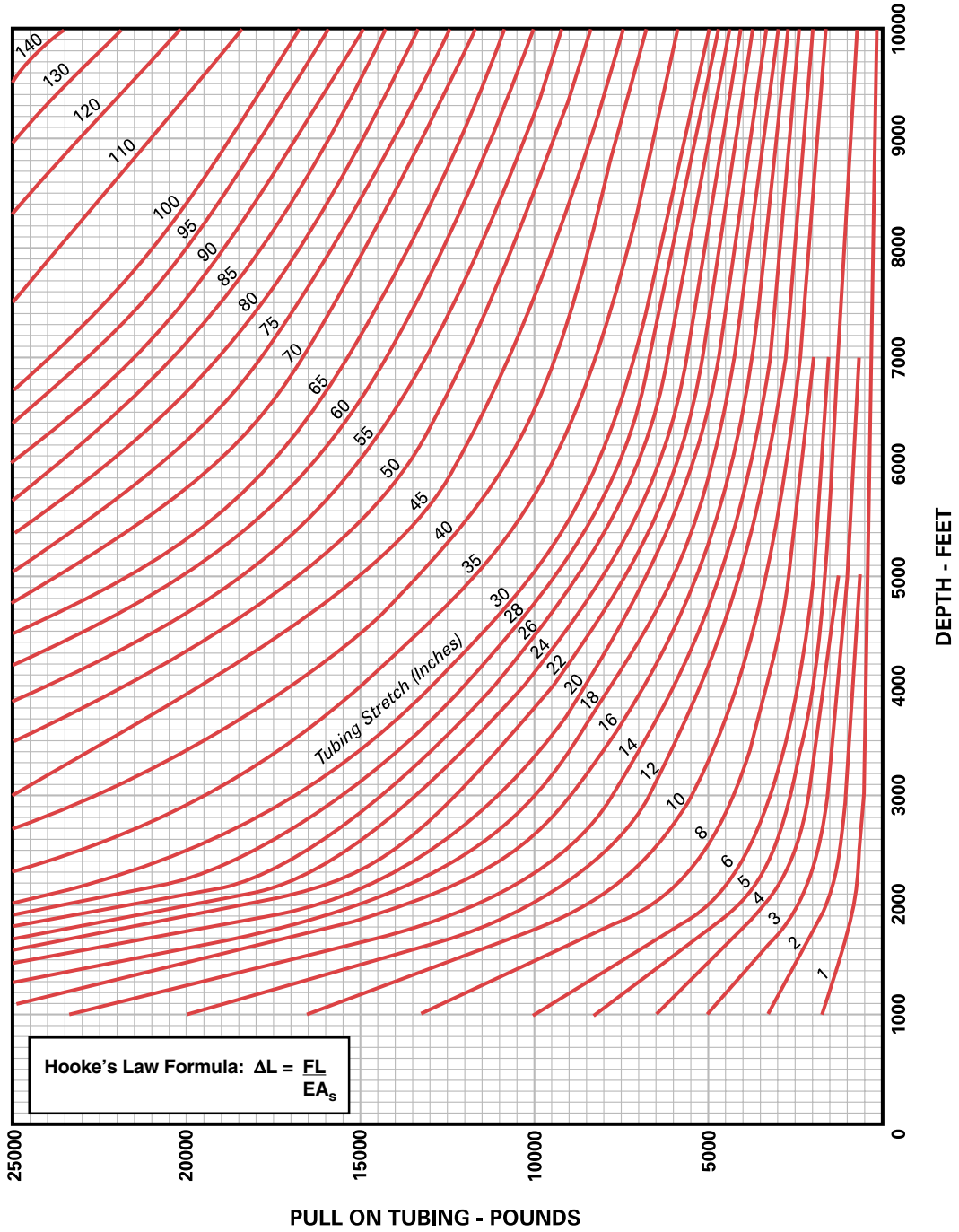

**Tubing Stretch Chart for 1.900" O.D. 2.9 #/Ft. E.U. or N.U. A.P.I. Tubing**

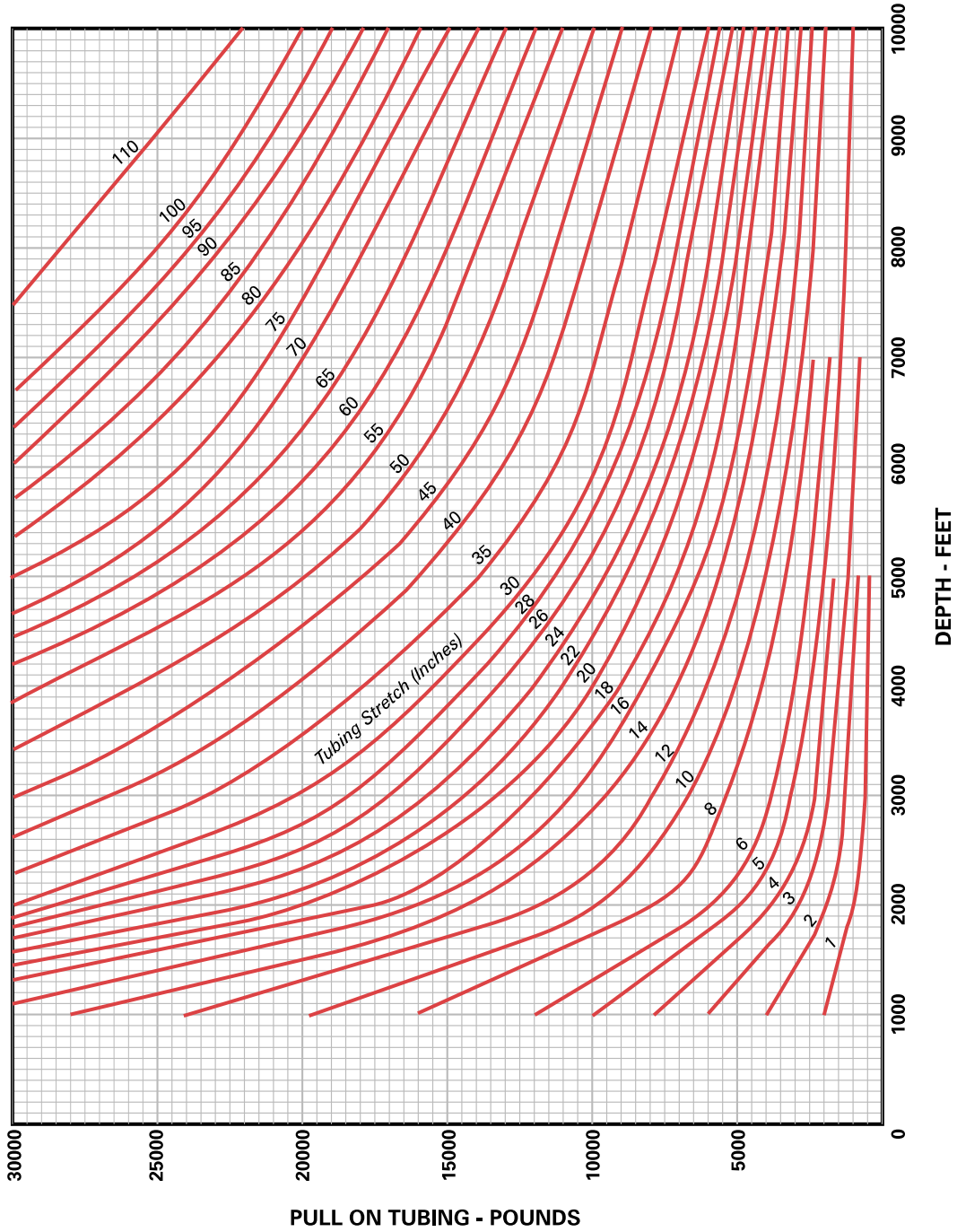

### Tubing Stretch Chart for 2.062" O.D. 3.25 #/Ft. E.U. or N.U. A.P.I. Tubing

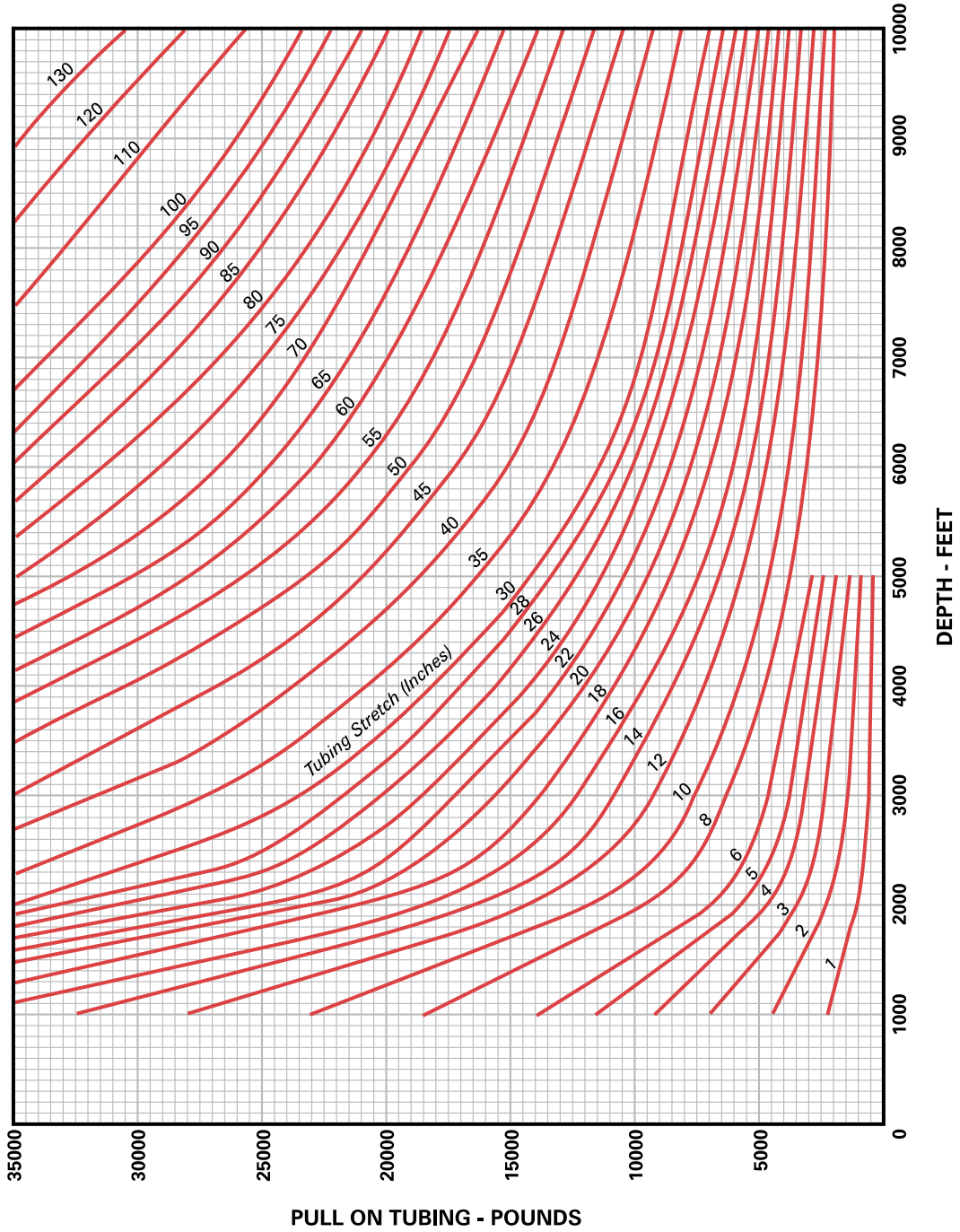

### Tubing Stretch Chart for 2<sup>3</sup>/<sub>8</sub>" O.D. 4.7 #/Ft. E.U. or N.U. A.P.I. Tubing

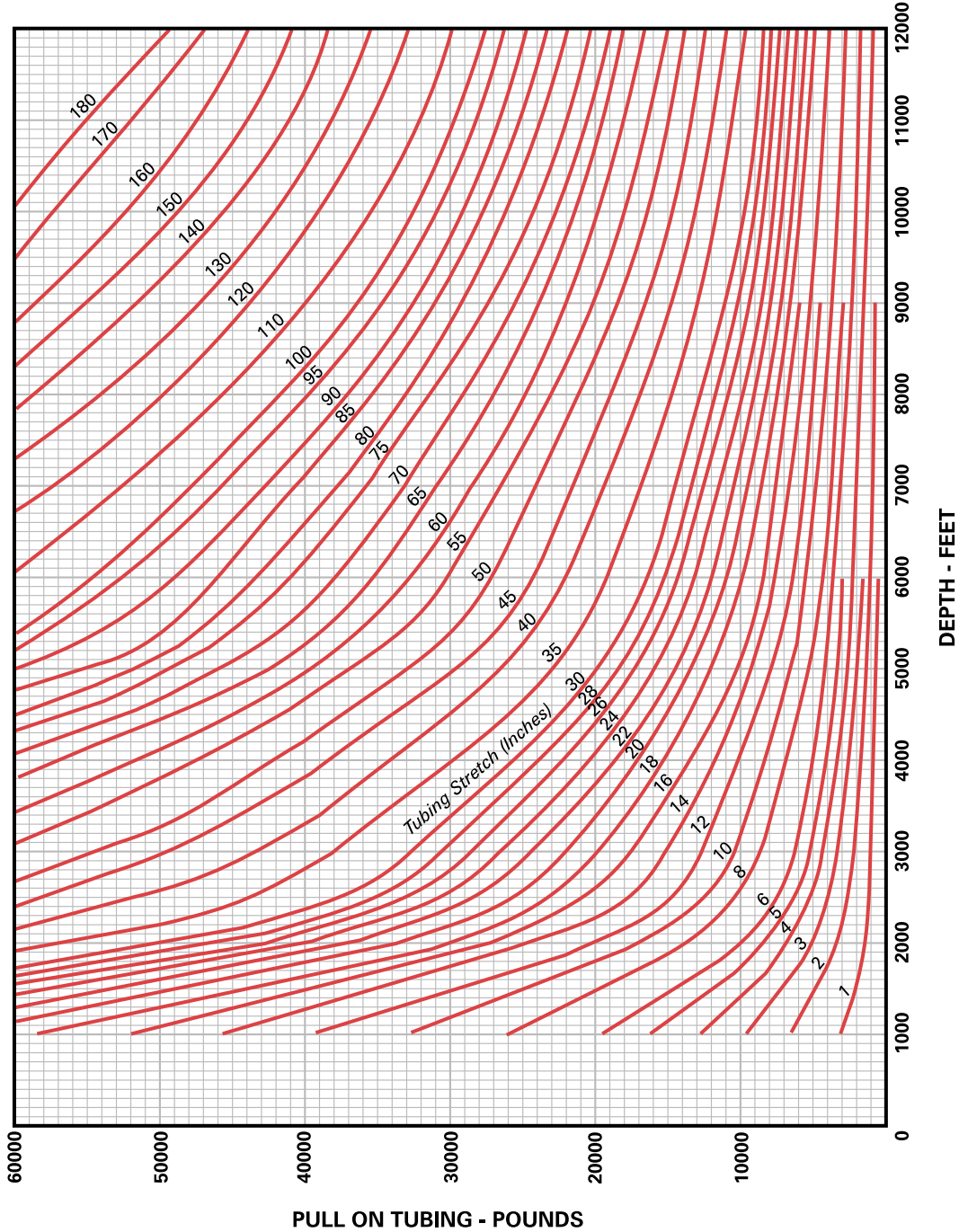

### Tubing Stretch Chart for 2<sup>7</sup>/<sub>8</sub>" O.D. 6.5 #/Ft. E.U. or N.U. A.P.I. Tubing

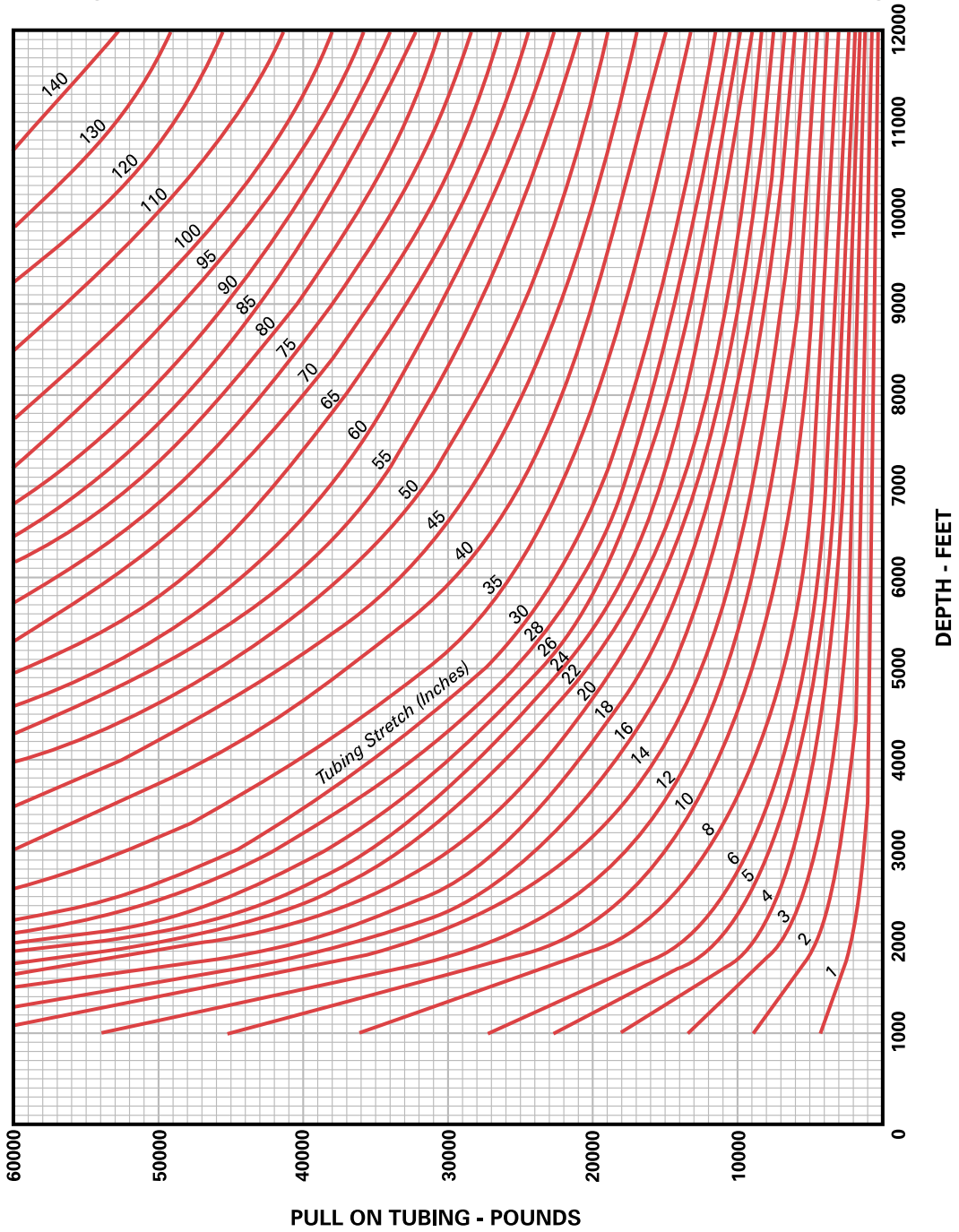



### Tubing Stretch Chart for 3½" O.D. 9.3 #/Ft. E.U. or N.U. A.P.I. Tubing

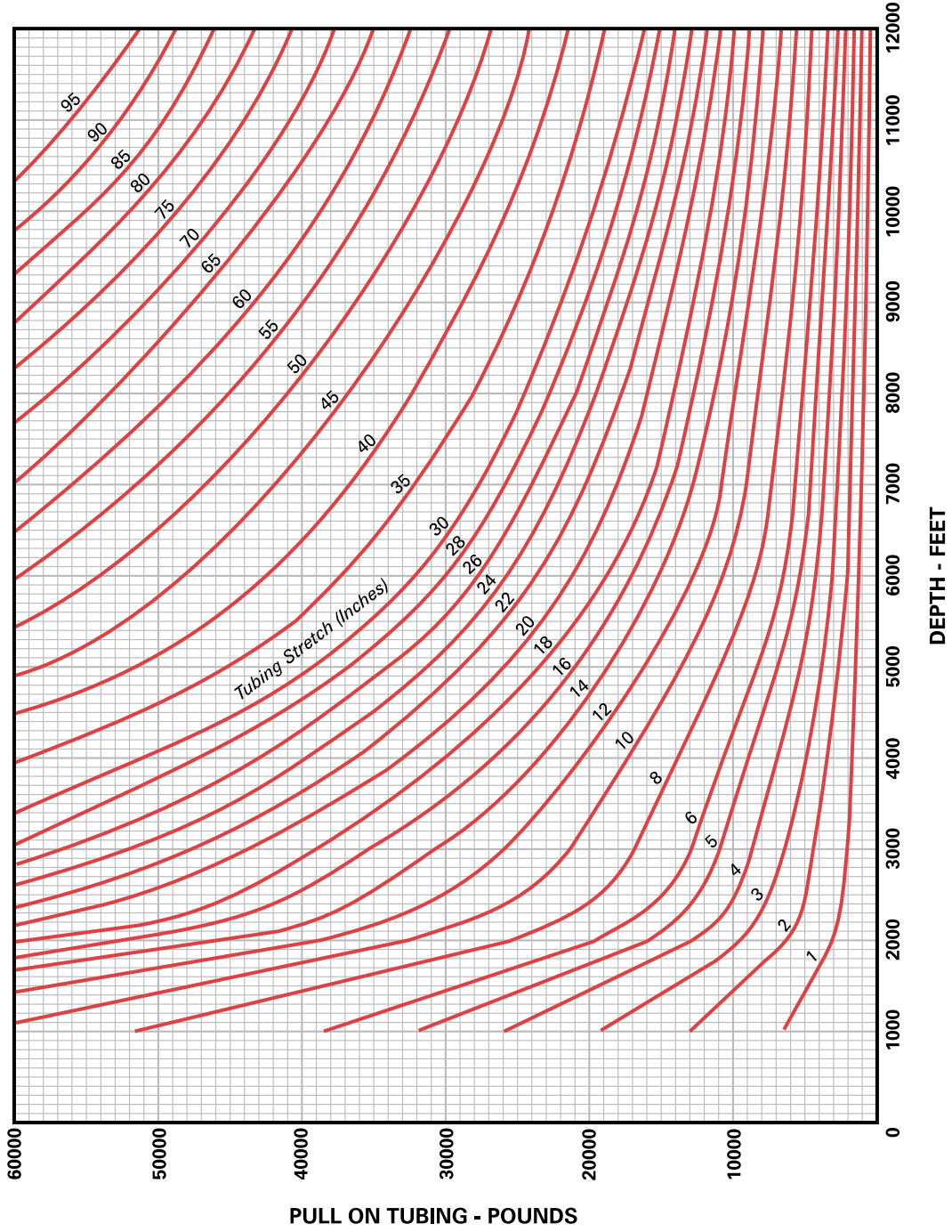

### Tubing Stretch Chart for 4" O.D. 10.9 #/Ft. E.U. or N.U. A.P.I. Tubing

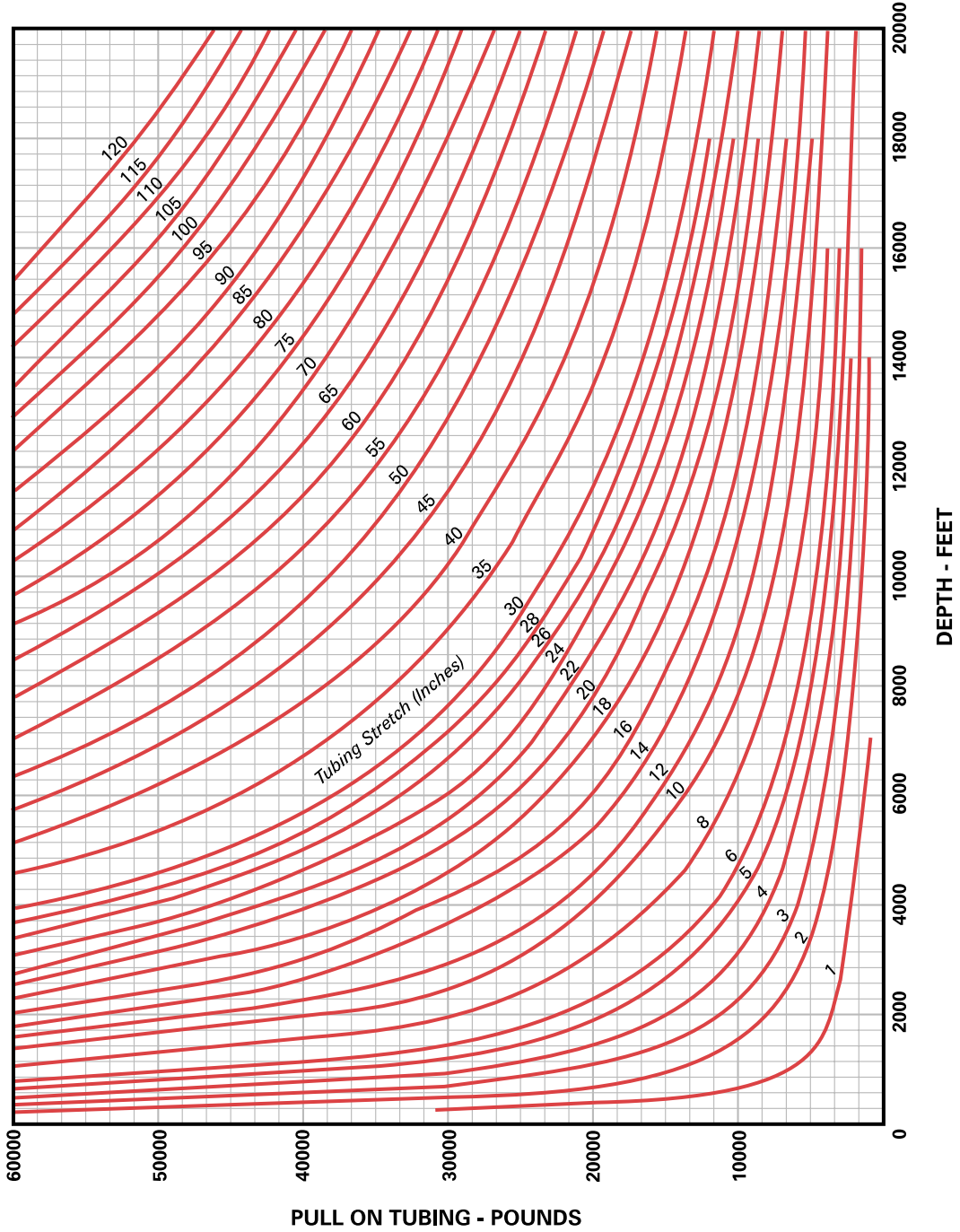

**Tubing Stretch Chart for 4½" O.D. 12.75 #/Ft. E.U. or N.U. A.P.I. Casing**

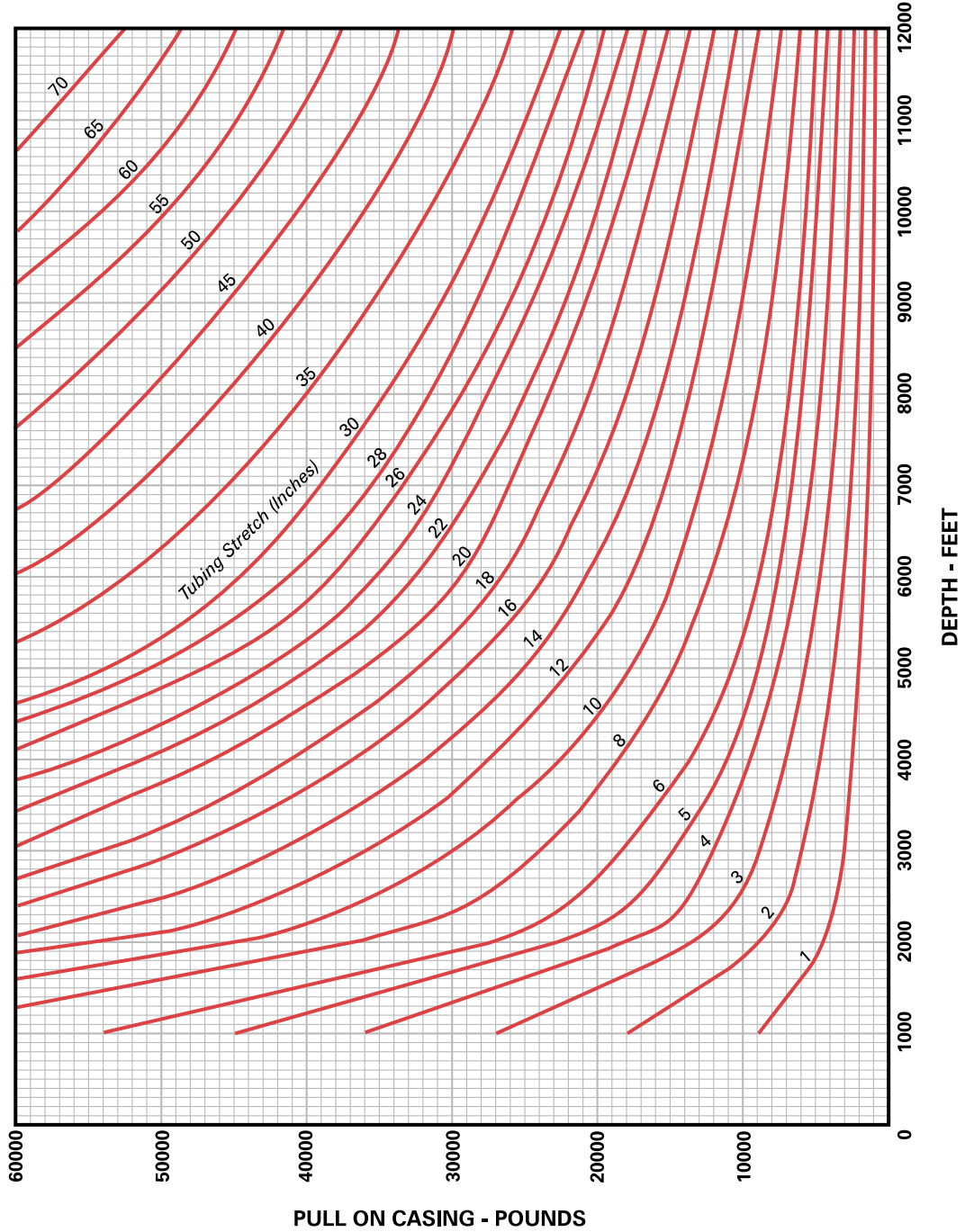

### Tubing Stretch Chart for 5" O.D. 15.0 #/Ft. E.U. or N.U. A.P.I. Casing

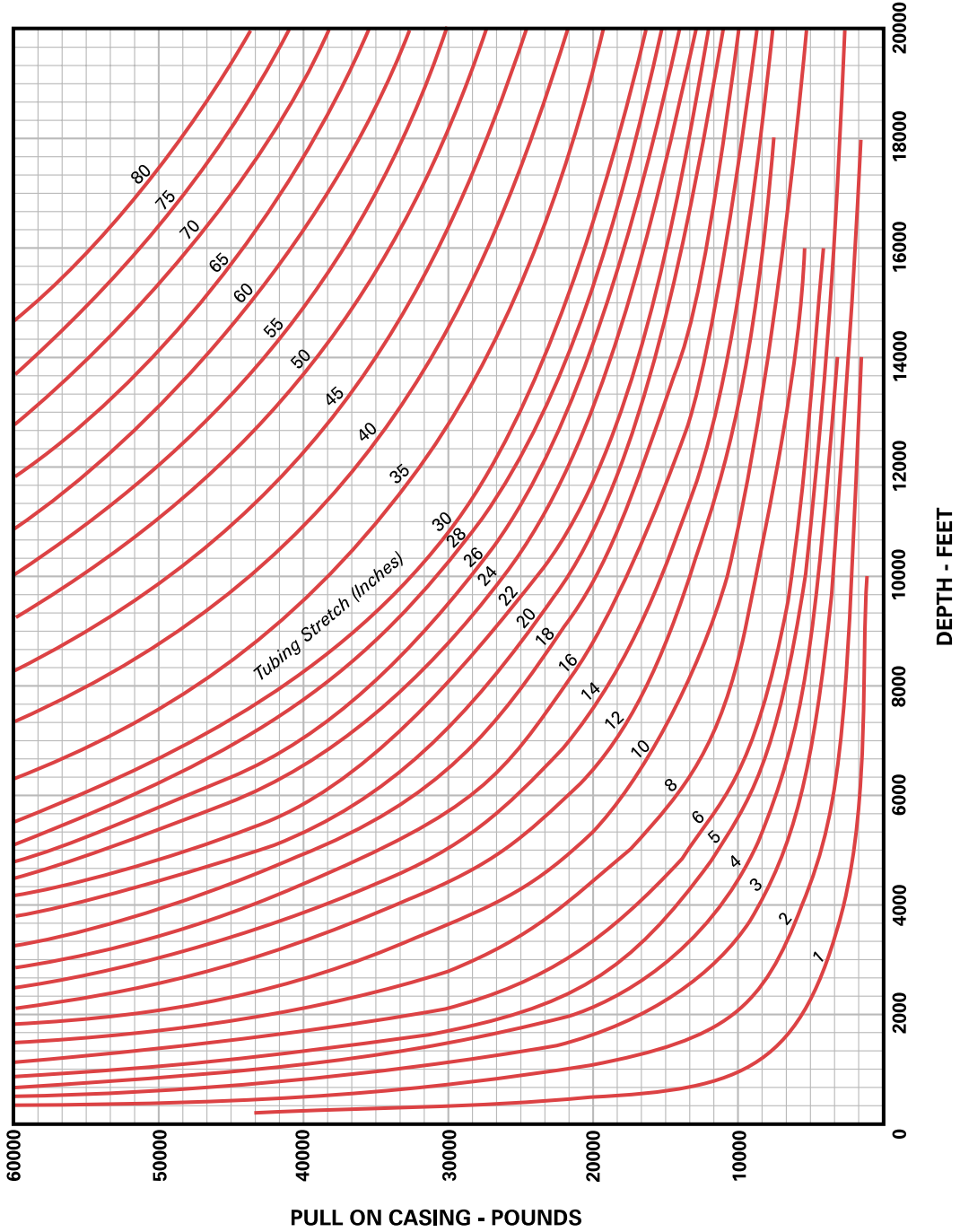

### Tubing Stretch Chart for 5½" O.D. 20 #/Ft. E.U. or N.U. A.P.I. Casing

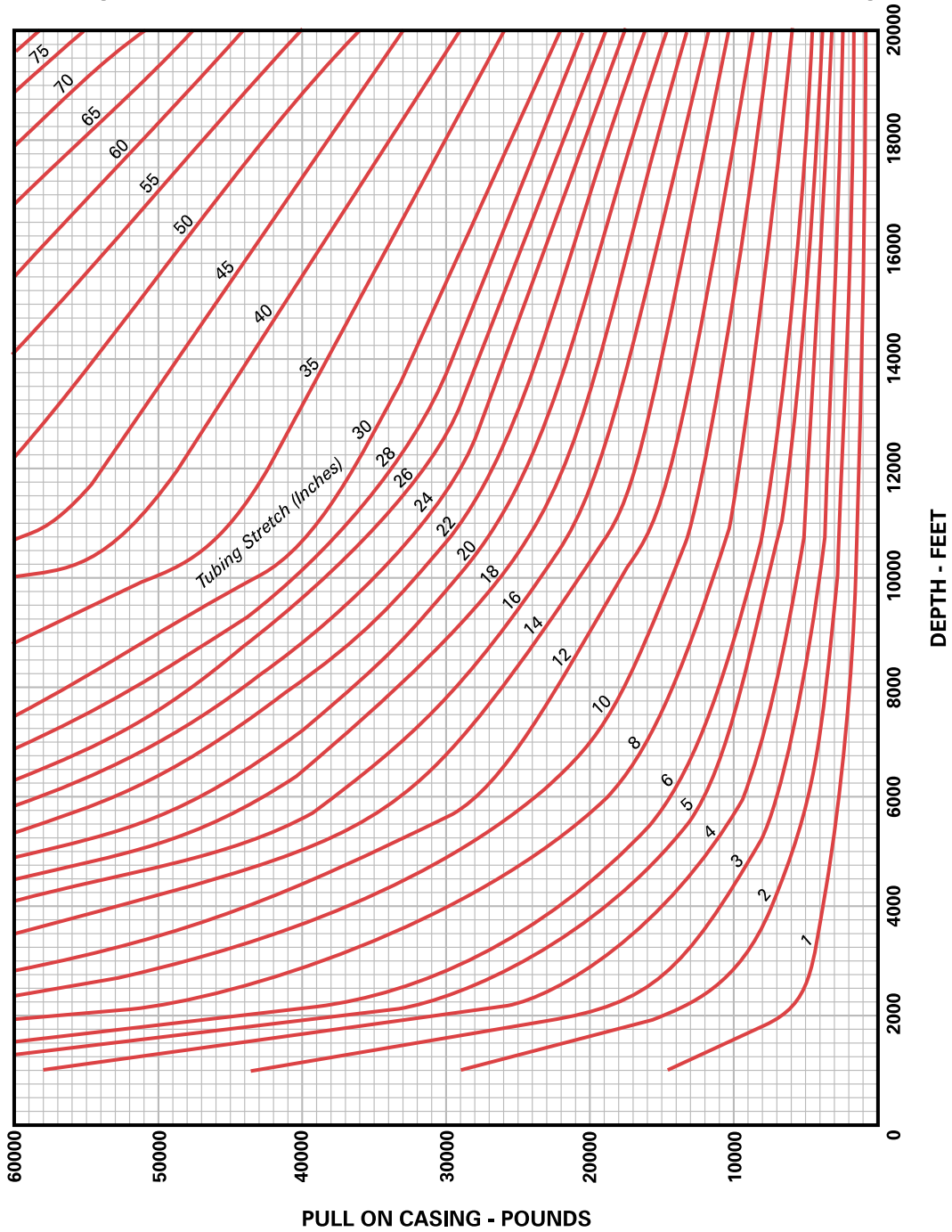

### Tubing Stretch Chart for 7" O.D. 26.0 #/Ft. E.U. or N.U. A.P.I. Casing

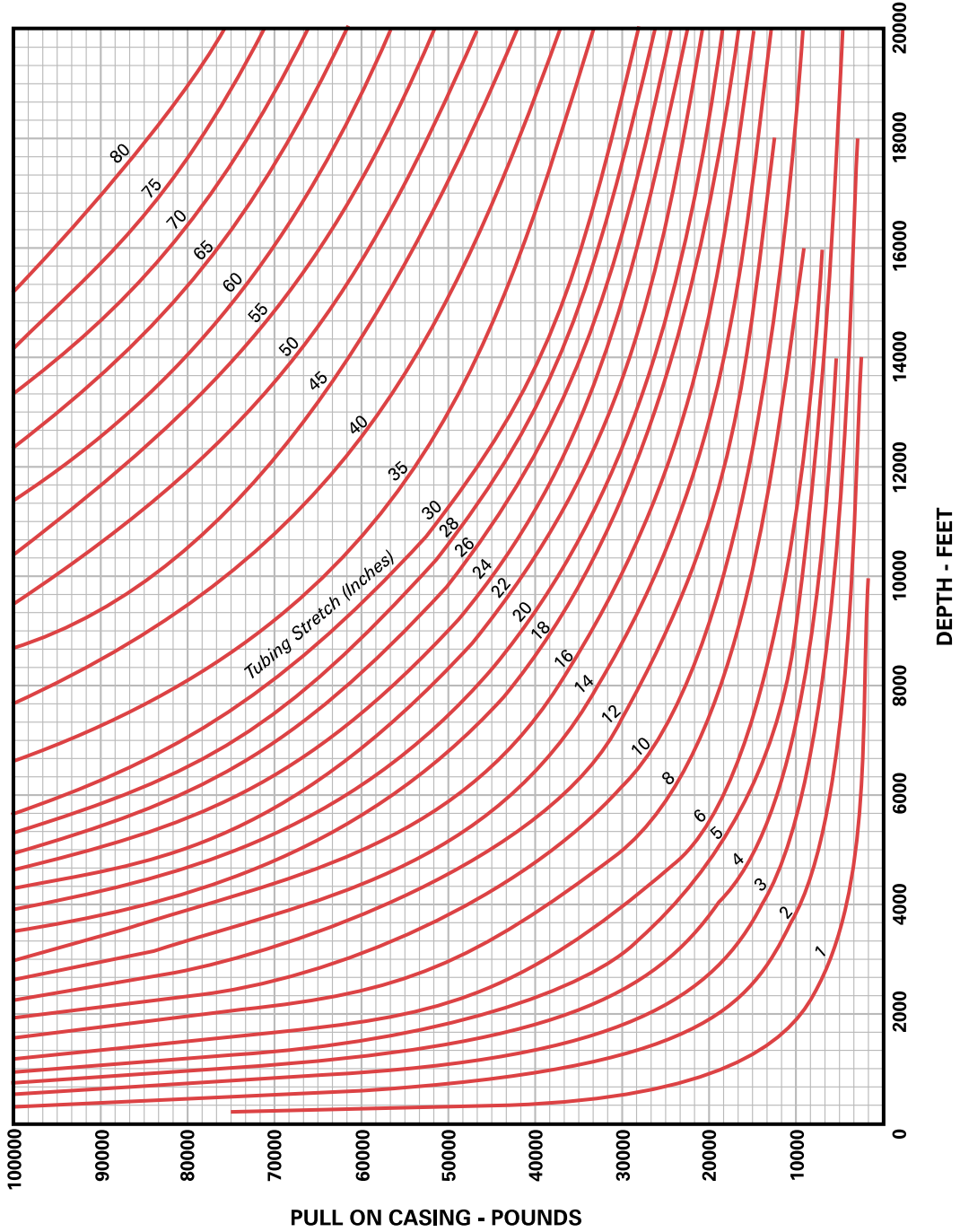

# WEIGHT ON PACKER CHART - 1.315" TUBING

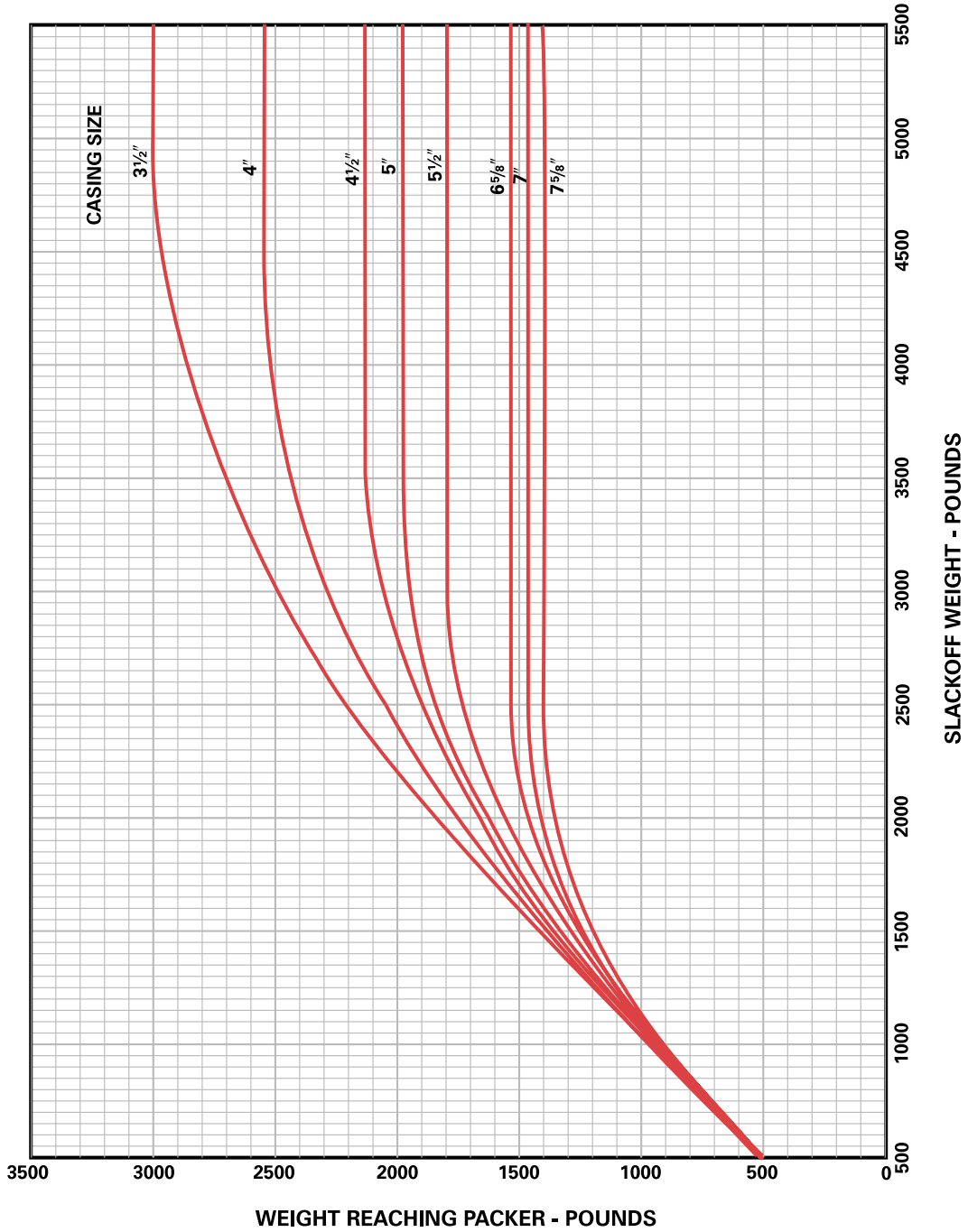

# WEIGHT ON PACKER CHART - 1.660" TUBING

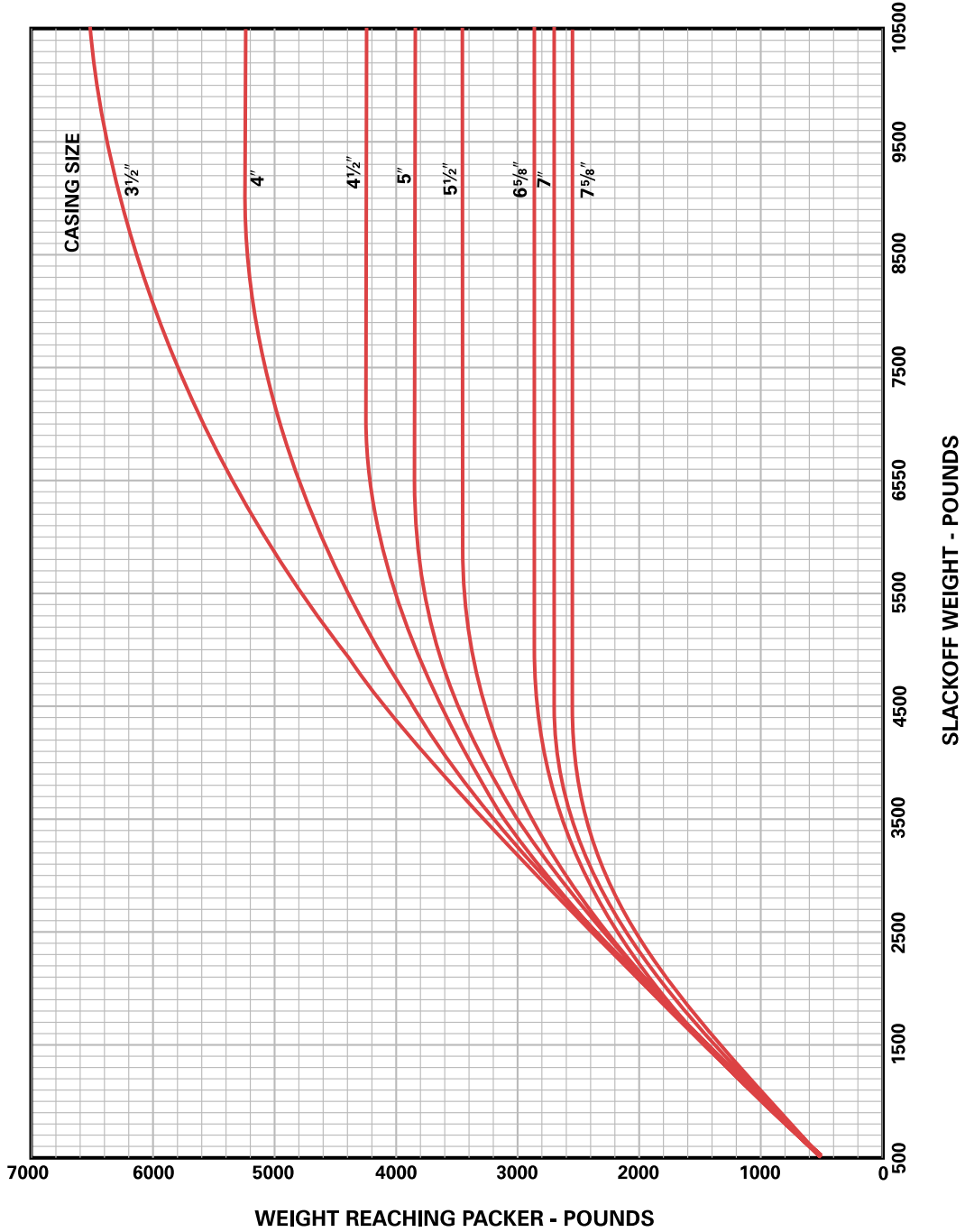



# WEIGHT ON PACKER CHART - 1.900" TUBING

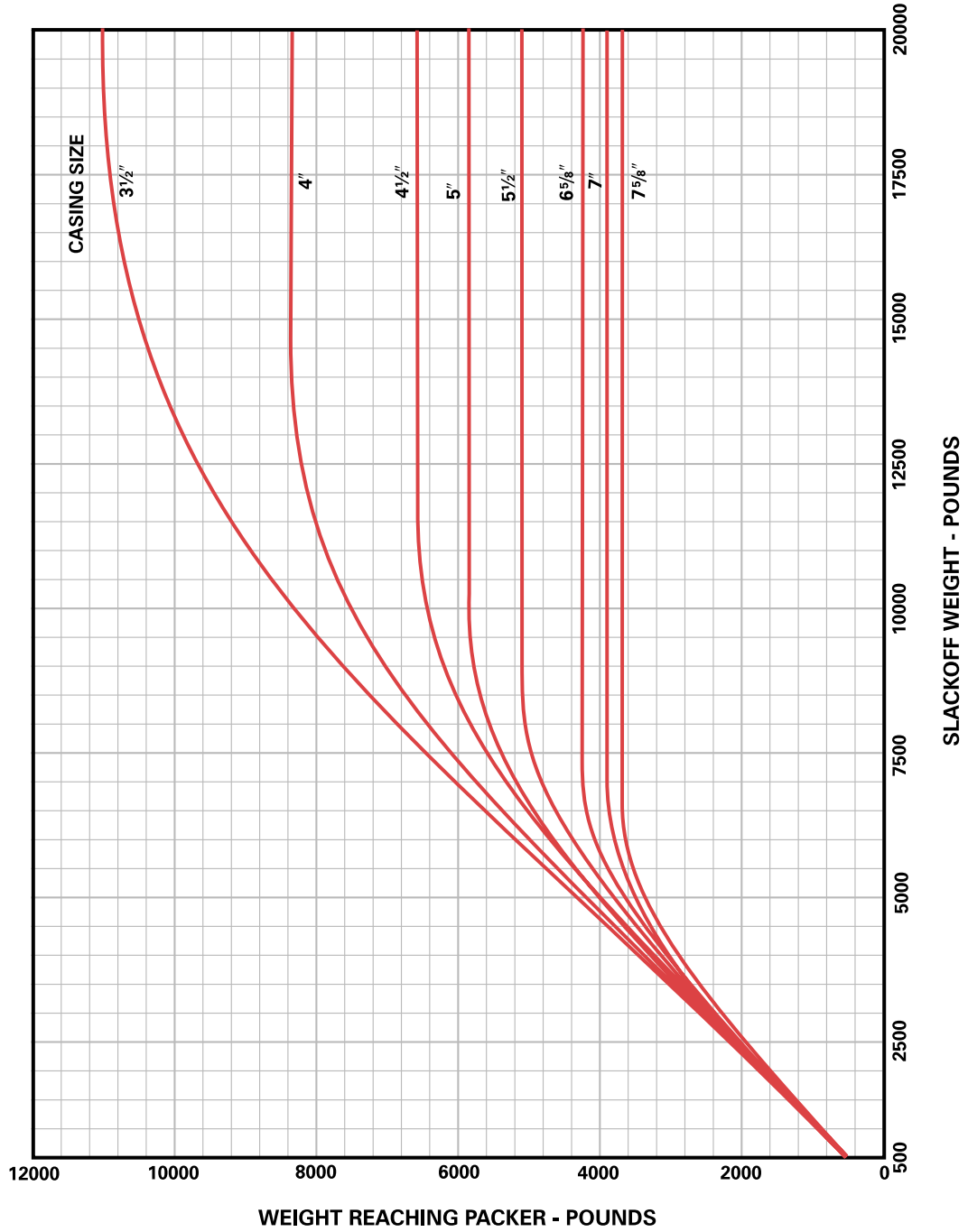

# WEIGHT ON PACKER CHART - 2 1/16" TUBING

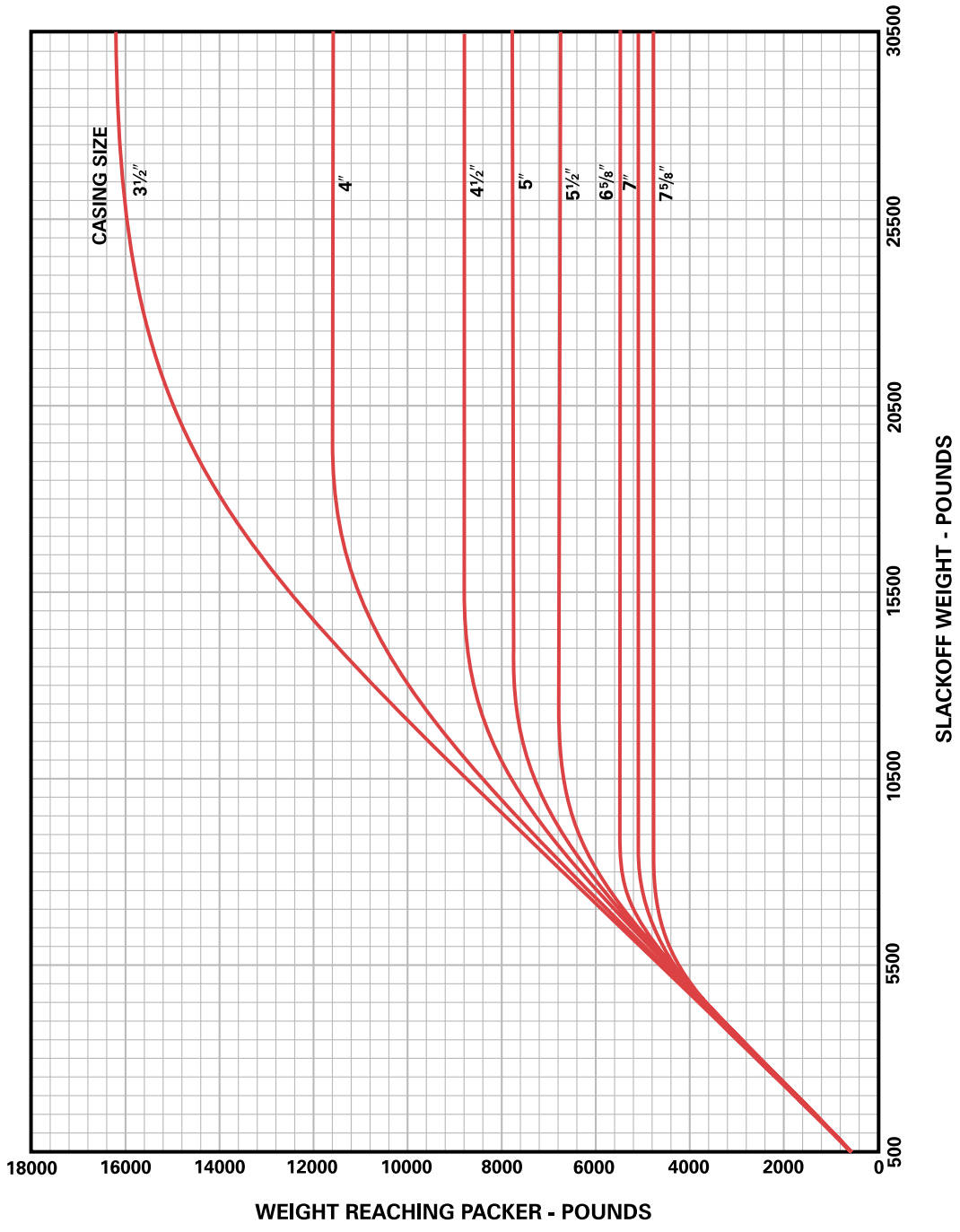

# WEIGHT ON PACKER CHART - 2 3/8" TUBING

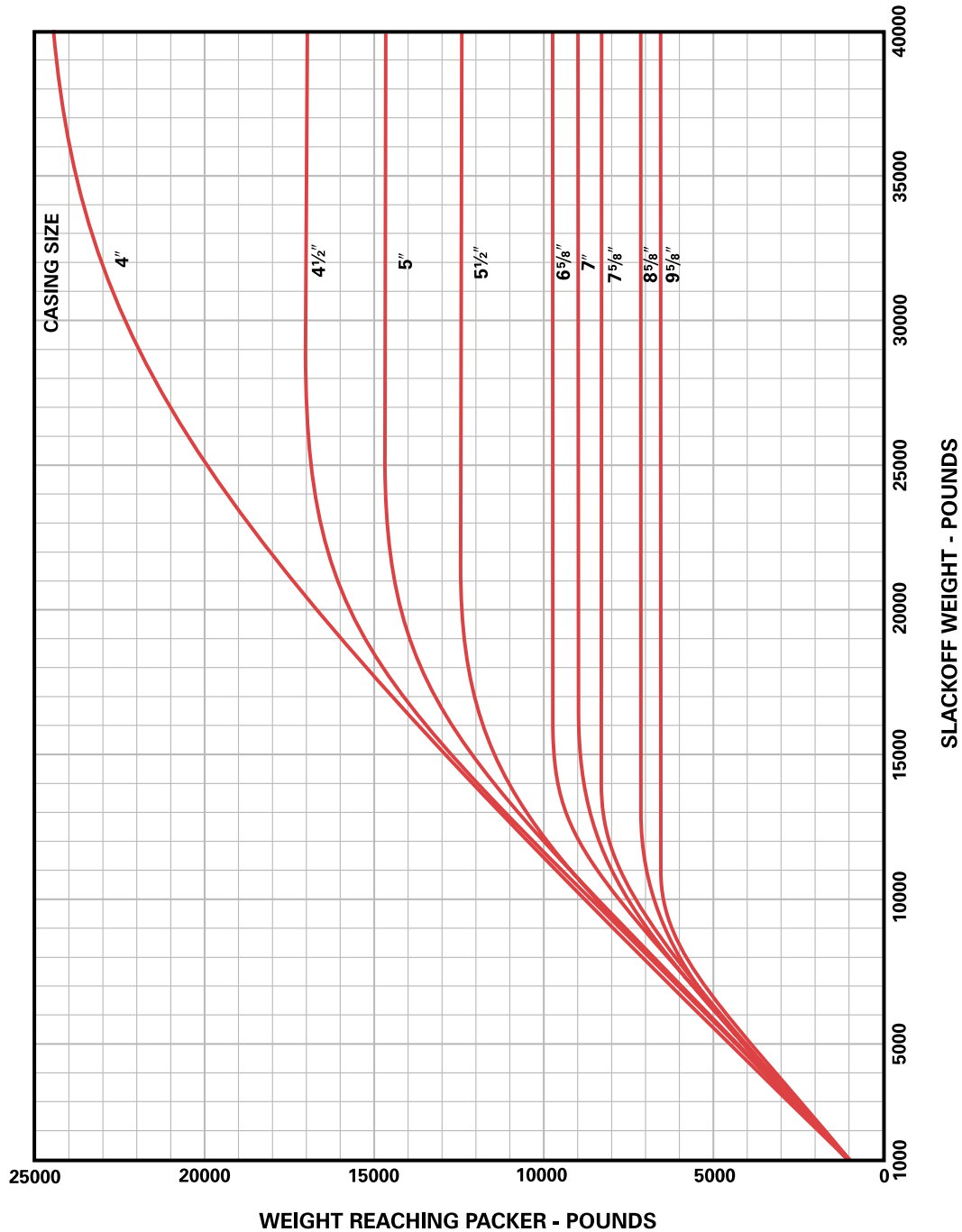

# WEIGHT ON PACKER CHART - 2<sup>7</sup>/<sub>8</sub>" TUBING

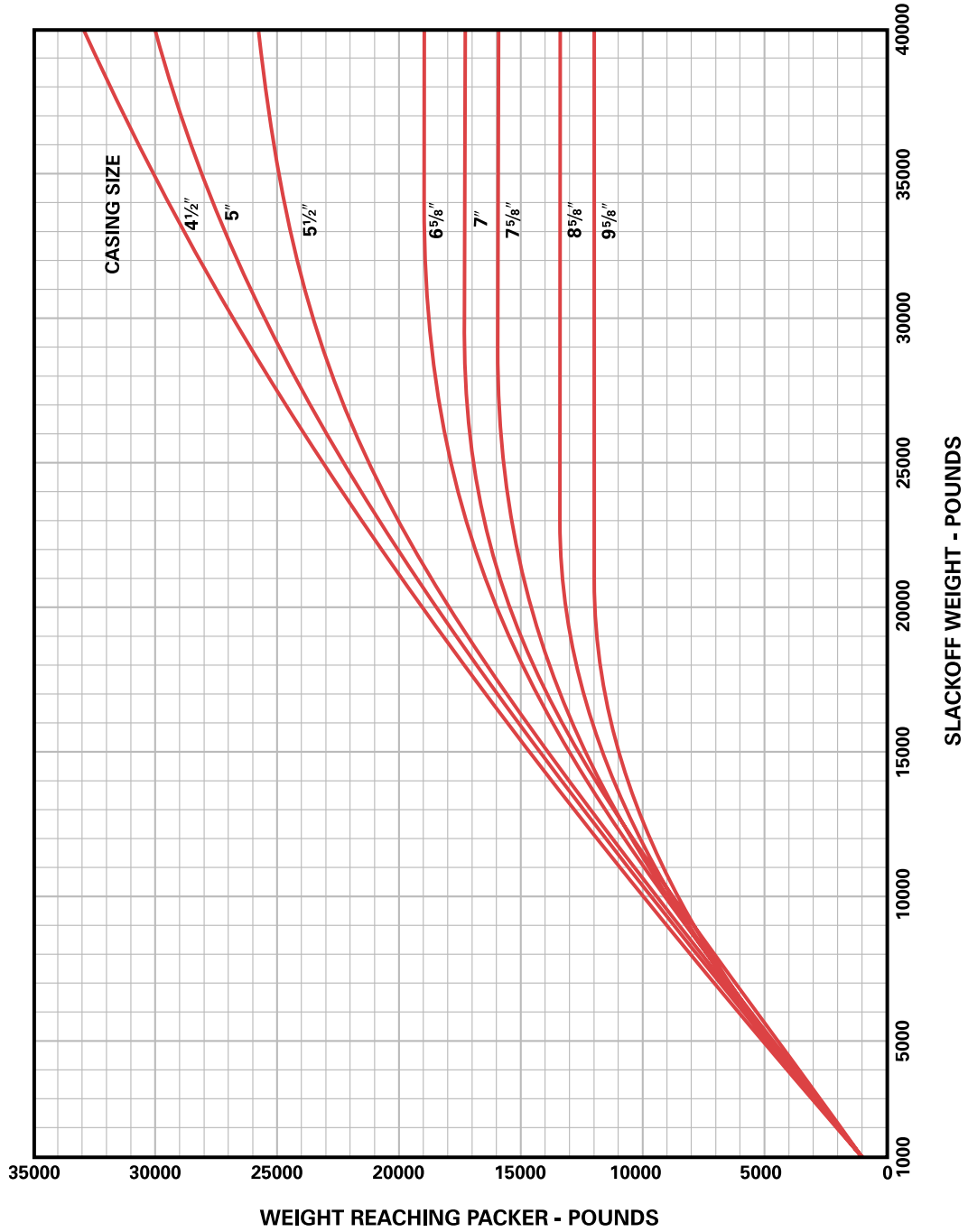

# WEIGHT ON PACKER CHART - 3 1/2" TUBING

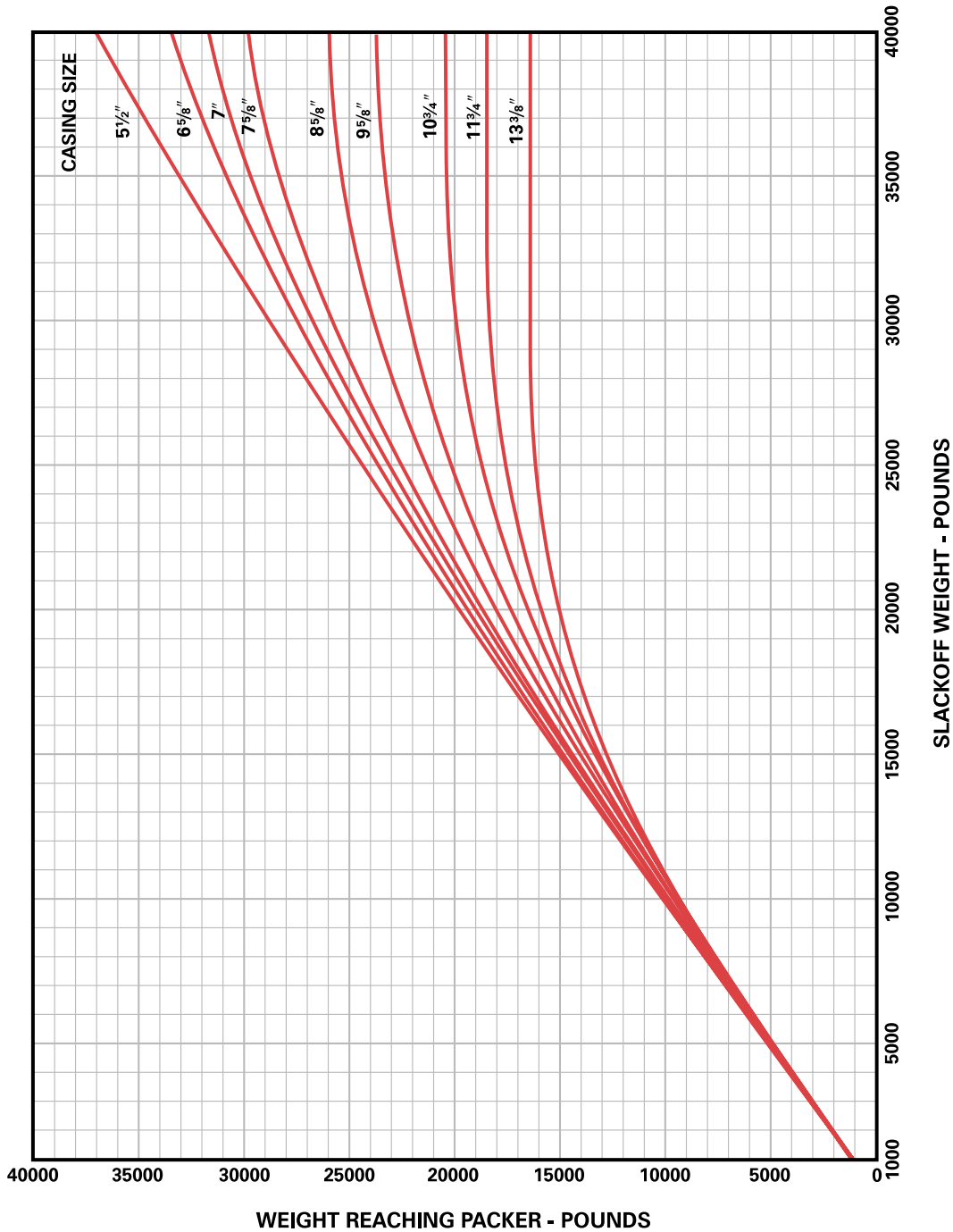

## WEIGHT ON PACKER CHART - 4" TUBING

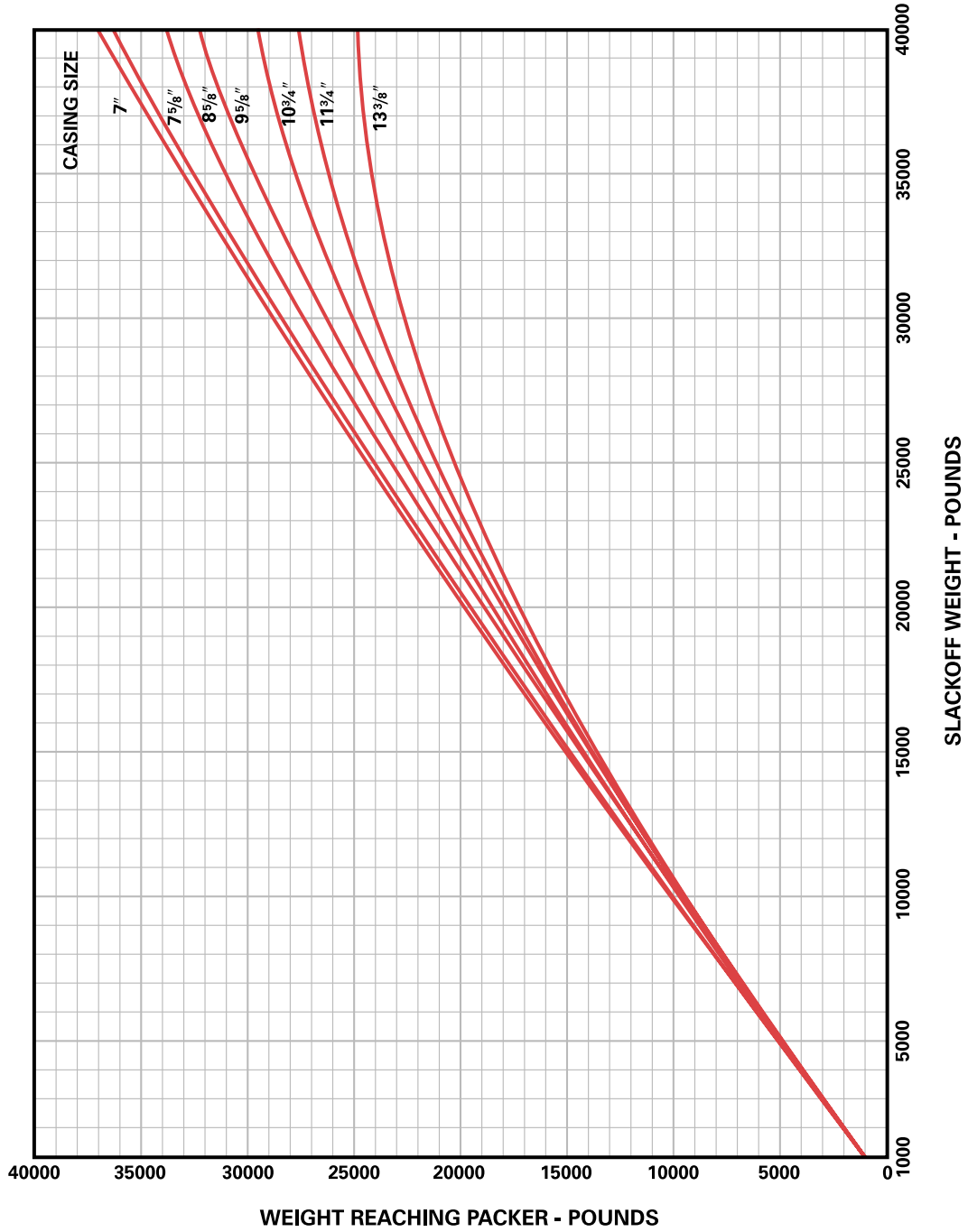

# WEIGHT ON PACKER CHART - 4 1/2" TUBING

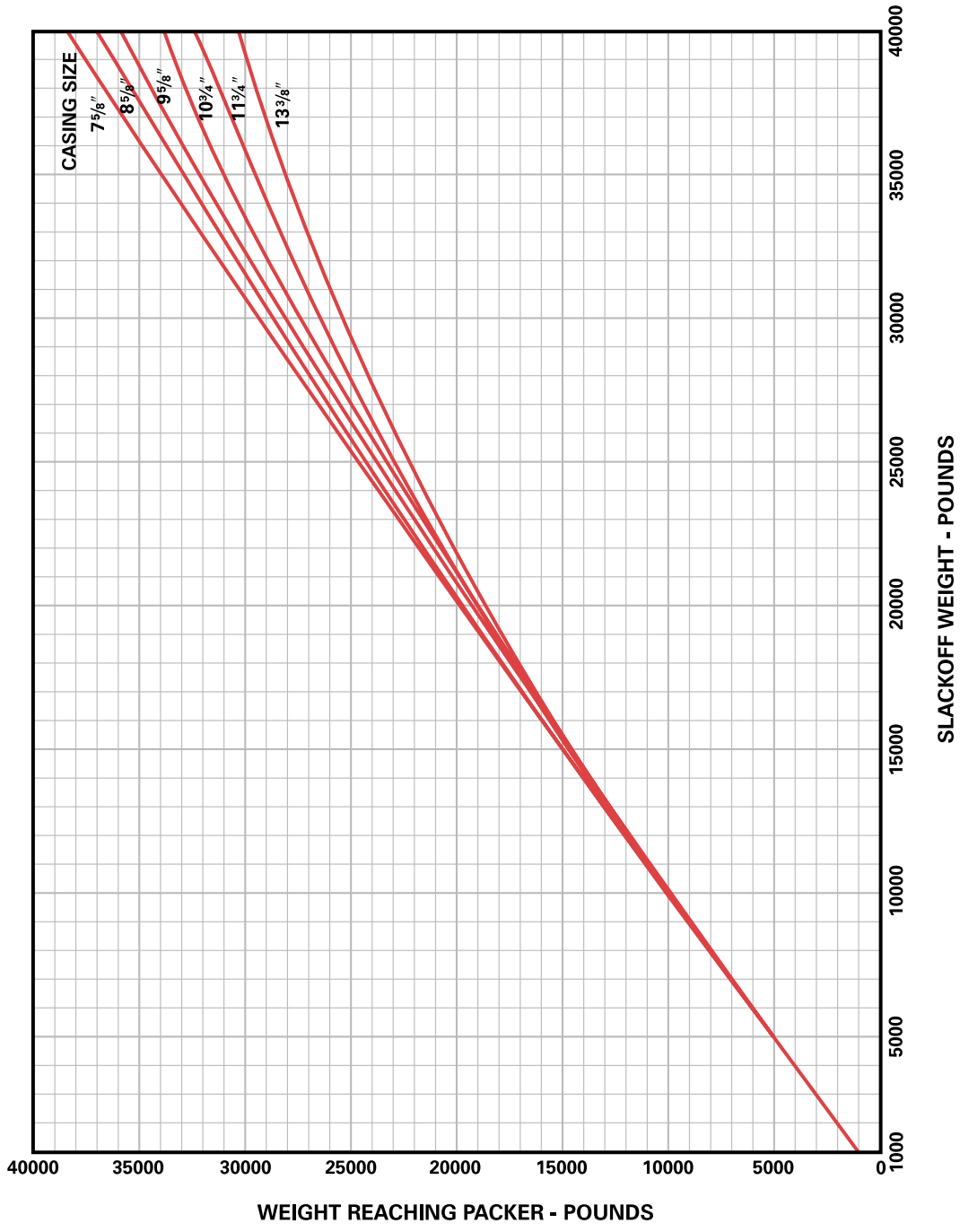







## WEIGHT OF SUCKER ROD STRING IN AIR

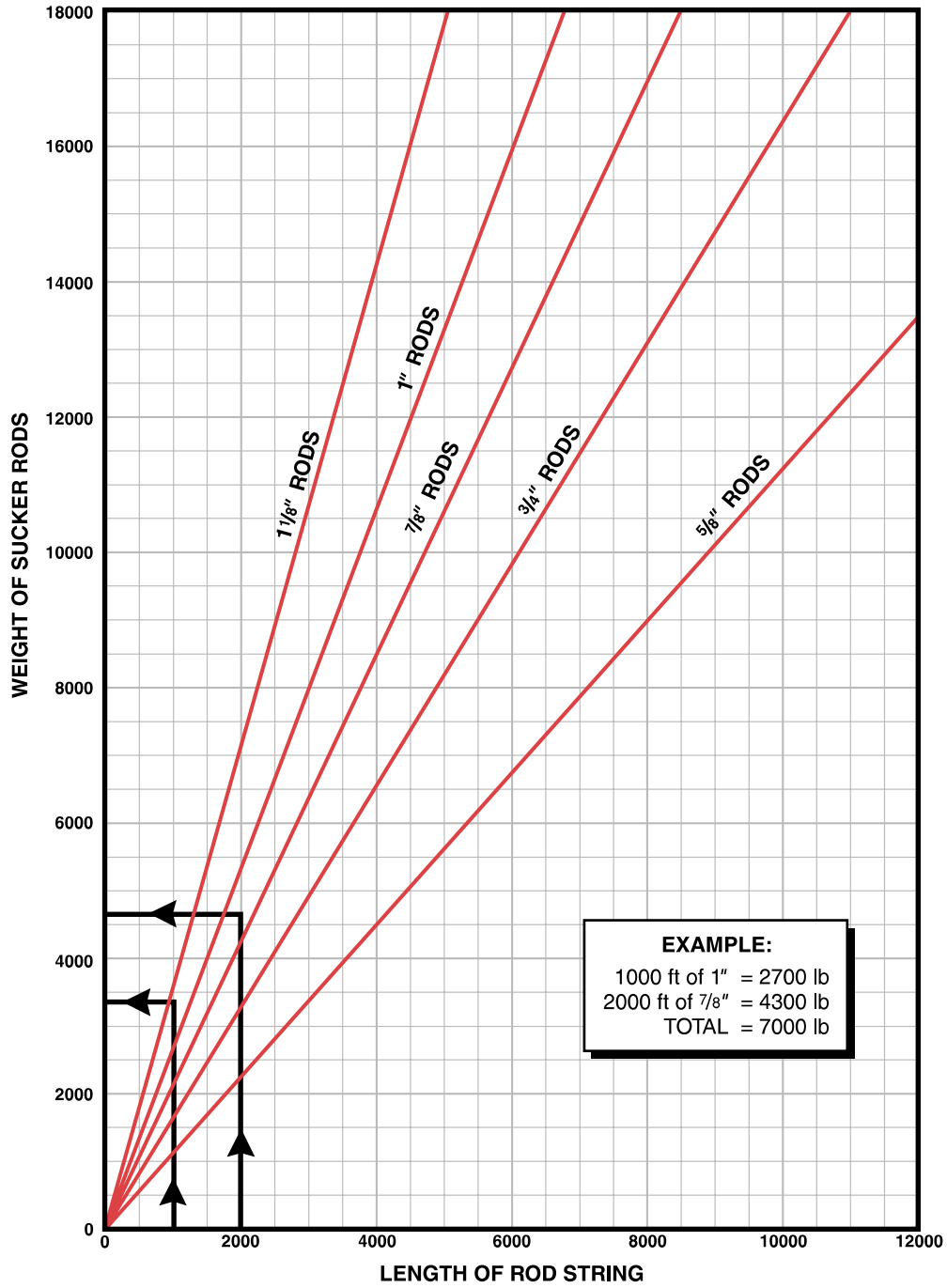

## 2.375" O.D. E.U. or N.U. A.P.I. TUBING

### TABLE 1: OPERATING FLUID LEVEL FACTOR

(Fluid Level After Pumping Annulus Down)

PUMP AND TUBING ANCHOR DEPTH (Feet)	1000	610	1550																			
	2000	520	1220	2080	3100																	
	3000	500	1110	1830	2660	3590	4640															
	4000	480	1060	1700	2430	3250	4140	5130	6300													
	5000	470	1020	1630	2300	3040	3840	4730	5670	6670	7750											
	6000	470	1000	1580	2210	2900	3650	4450	5310	6220	7200	8210	9300									
	7000	460	980	1540	2150	2800	3500	4260	5060	5900	6800	7740	8730	9760	10850							
	8000	460	970	1520	2100	2730	3400	4120	4870	5660	6510	7380	8300	9260	10270	11310	12390					
	9000	460	960	1500	2060	2670	3310	4010	4720	5470	6270	7100	7970	8870	9820	10790	11800	12850	13940			
	10000	460	960	1480	2040	2630	3250	3910	4600	5320	6090	6870	7700	8550	9450	10370	11330	12320	13350	14400	15490	
		500	1000	1500	2000	2500	3000	3500	4000	4500	5000	5500	6000	6500	7000	7500	8000	8500	9000	9500	10000	

Fluid Gradient .5 psi/ft.

### TABLE 2: TEMPERATURE INCREASE FACTOR

°F	10	20	30	40	50	60	70	80	90	100	110	120	130	140	150	160	170	180	190	200
F <sub>2</sub>	1350	2700	4050	5400	6750	8100	9450	10800	12150	13500	14850	16200	17550	18900	20200	21600	22900	24300	25600	27000

- To Obtain F<sub>2</sub>:
- (1) Subtract the mean yearly temperature for area in which well is located from the temperature of the well fluid at the surface.
  - (2) Locate this difference in the °F column.
  - (3) Read F<sub>2</sub> immediately below.

### TABLE 3: INITIAL WELL FLUID LEVEL FACTOR

(Fluid Level When Anchor Set)

PUMP AND TUBING ANCHOR DEPTH (Feet)	1000	180	460																			
	2000	150	360	610	910																	
	3000	150	330	540	780	1060	1370															
	4000	140	310	500	720	960	1220	1510	1820													
	5000	140	300	480	680	890	1130	1390	1670	1960	2290											
	6000	140	290	460	650	850	1070	1310	1560	1830	2130	2430	2740									
	7000	140	290	450	630	820	1030	1250	1490	1740	2010	2290	2580	2880	3200							
	8000	140	280	450	620	800	1000	1210	1430	1670	1920	2180	2450	2730	3030	3340	3660					
	9000	140	280	440	610	780	980	1170	1390	1610	1850	2100	2350	2620	2900	3180	3480	3790	4110			
	10000	130	280	430	600	770	960	1150	1350	1570	1800	2030	2270	2530	2790	3060	3340	3630	3930	4250	4570	
		500	1000	1500	2000	2500	3000	3500	4000	4500	5000	5500	6000	6500	7000	7500	8000	8500	9000	9500	10000	

Fluid Gradient .5 psi/ft.





<b>SHEAR PIN SELECTION TABLE FOR REDUCED SHEAR OUT VALVES, TUBING &amp; ANCHOR CATCHER</b>	
Prestrain ( $F_T$ ) Determined From Calculations	Minimum Total Shear Value of Shear Pins Including Safety Factor
0 - 10,000 lbs	25,000 lbs
10,000 - 20,000 lbs	30,000 lbs
20,000 - 30,000 lbs	40,000 lbs
30,000 - 40,000 lbs	50,000 lbs

<b>OPERATING FLUID LEVEL (ft)</b>	<b>PUMP PLUNGER SIZE</b>			
	<b>1<sup>1</sup>/<sub>4</sub>"</b>	<b>1<sup>1</sup>/<sub>2</sub>"</b>	<b>1<sup>3</sup>/<sub>4</sub>"</b>	<b>2"</b>
1,000	615	885	1,200	1,570
2,000	1,230	1,770	2,400	3,140
3,000	1,845	2,655	3,600	4,710
4,000	2,460	3,540	4,800	6,280
6,000	3,690	5,310	7,200	9,420
7,000	4,305	6,195	8,400	10,990
8,000	4,920	7,080	9,600	12,560
9,000	5,535	7,965	10,800	14,130
10,000	6,150	8,850	12,000	15,700





**Schlumberger**

**Appendix H  
MISCELLANEOUS**







## Decimal Equivalents of Fractions of an Inch in Inches and Millimeters

Fraction	Dec. Equiv.	Millimeters	Fraction	Dec. Equiv.	Millimeters
$1/64$	.015625	0.397	$33/64$	.515625	13.097
$1/32$	.03125	0.794	$17/32$	.53125	13.494
$3/64$	.046875	1.191	$35/64$	.546875	13.891
$1/16$	.0625	1.588	$9/16$	.5625	14.288
$5/64$	.078125	1.984	$37/64$	.578125	14.684
$3/32$	.09375	2.381	$19/32$	.59375	15.081
$7/64$	.109375	2.778	$39/64$	.609375	15.478
$1/8$	.1250	3.175	$5/8$	.6250	15.875
$9/64$	.140625	3.572	$41/64$	.640625	16.272
$5/32$	.15625	3.969	$21/32$	.65625	16.669
$11/64$	.171875	4.366	$43/64$	.671875	17.066
$3/16$	.1875	4.763	$11/16$	.6875	17.463
$13/64$	.203125	5.159	$45/64$	.703125	17.859
$7/32$	.21875	5.556	$23/32$	.71875	18.256
$15/64$	.234375	5.953	$47/64$	.734375	18.653
$1/4$	.2500	6.350	$3/4$	.7500	19.050
$17/64$	.265625	66.747	$49/64$	.765625	19.447
$9/32$	.28125	7.144	$25/32$	.78125	19.844
$19/64$	.296875	7.541	$51/64$	.796875	20.241
$5/16$	.3125	7.938	$13/16$	.8125	20.638
$21/64$	.328125	8.334	$53/64$	.828125	21.034
$11/32$	.34375	8.731	$27/32$	.84375	21.431
$23/64$	.359375	9.128	$55/64$	.859375	21.828
$3/8$	.3750	9.525	$7/8$	.8750	22.225
$25/64$	.390625	9.922	$57/64$	.890625	22.622
$13/32$	.40625	10.319	$29/32$	.90625	23.019
$27/64$	.421875	10.716	$59/64$	.921875	23.416
$7/16$	.4375	11.113	$15/16$	.9375	23.813
$29/64$	.453125	11.509	$61/64$	.953125	24.209
$15/32$	.46875	11.906	$31/32$	.96875	24.606
$31/64$	.484375	12.303	$63/64$	.984375	25.003
$1/2$	.5000	12.700	1	1.000	25.400





## Area of Circles

**D = Diameter    Area = .785 D<sup>2</sup>**

Dec.	Frac.	Inches										Dec.	Frac.
		0	1	2	3	4	5	6	7	8			
0	0	.7854	3.1416	7.0686	12.566	19.635	28.274	38.485	50.266	0	0		
.0156	1/64	.8101	3.1909	7.1424	12.665	19.753	28.422	38.656	50.462	.0156	1/64		
.0312	1/32	.8352	3.2405	7.2166	12.763	19.881	28.570	38.829	50.659	.0312	1/32		
.0468	3/64	.8607	3.2906	7.2912	12.863	20.005	28.718	39.002	50.856	.0468	3/64		
.0625	1/16	.8866	3.3410	7.3662	12.962	20.129	28.866	39.175	51.054	.0625	1/16		
.0781	5/64	.8929	3.3918	7.4415	13.062	20.253	29.015	39.348	51.252	.0781	5/64		
.0937	3/32	.9306	3.4430	7.5173	13.162	20.378	29.165	39.522	51.450	.0937	3/32		
.1093	1/64	.9666	3.4946	7.5934	13.263	20.503	29.315	39.696	51.649	.1093	1/64		
.1250	1/8	.9940	3.5466	7.6699	13.364	20.629	29.465	39.871	51.849	.1250	1/8		
.1406	9/64	1.0218	3.5989	7.7468	13.465	20.755	29.615	40.946	52.048	.1406	9/64		
.1562	5/32	1.0500	3.6516	7.8241	13.567	20.881	29.766	40.222	52.248	.1562	5/32		
.1718	11/64	1.0786	3.7048	7.9017	13.669	21.008	29.917	40.398	52.448	.1718	11/64		
.1875	3/16	1.1075	3.7583	7.9798	13.772	21.135	30.969	40.574	52.649	.1875	3/16		
.2031	13/64	1.1369	3.8121	8.0582	13.875	21.263	30.221	40.750	52.850	.2031	13/64		
.2187	7/32	1.1666	3.8664	8.1370	13.978	21.391	30.374	40.927	53.052	.2187	7/32		
.2343	15/64	1.1967	3.9211	8.2162	14.082	21.519	30.526	41.105	53.254	.2343	15/64		

## Area of Circles

**D = Diameter    Area = .785 D<sup>2</sup>**

Dec.	Frac.	Inches										Dec.	Frac.
		Dia.	9	10	11	12	13	14	15	16	17		
0	0	78.540	63.617	80.516	95.033	113.10	132.73	153.94	176.71	201.06	226.98	0	0
.0156	1/64	78.785	63.838	80.764	95.303	113.39	133.05	154.28	177.08	201.45	227.40	.0156	1/64
.0312	1/32	79.031	64.060	81.013	95.574	113.69	133.37	154.63	177.45	201.85	227.82	.0312	1/32
.0468	3/64	79.278	64.282	81.263	95.845	113.98	133.69	154.97	177.82	202.24	228.23	.0468	3/64
.0625	1/16	79.525	64.504	81.513	96.116	114.23	134.01	155.32	178.19	202.64	228.65	.0625	1/16
.0781	5/64	79.772	64.727	81.763	96.388	114.57	134.33	155.66	178.56	203.03	229.07	.0781	5/64
.0937	3/32	80.019	64.950	82.014	96.660	114.87	134.65	156.01	178.93	203.43	229.49	.0937	3/32
.1093	7/64	80.267	65.173	82.265	96.932	115.17	134.98	156.35	179.30	203.82	229.91	.1093	7/64
.1250	1/8	80.516	65.397	82.516	97.205	115.47	135.30	156.70	179.67	204.22	230.33	.1250	1/8
.1406	9/64	80.764	65.621	82.764	97.479	115.76	135.62	157.05	180.04	204.61	230.75	.1406	9/64
.1562	5/32	81.013	65.845	83.013	97.752	116.06	135.94	157.39	180.42	205.01	231.17	.1562	5/32
.1718	11/64	81.263	66.070	83.263	98.026	116.36	136.27	157.74	180.79	205.40	231.59	.1718	11/64
.1875	3/16	81.513	66.296	83.513	98.301	116.66	136.59	158.09	181.16	205.80	232.01	.1875	3/16
.2031	13/64	81.763	66.521	83.763	98.575	116.96	136.91	158.44	181.53	206.20	232.44	.2031	13/64
.2187	7/32	82.014	66.747	84.014	98.850	117.26	137.24	158.79	181.91	206.60	232.86	.2187	7/32
.2343	15/64	82.265	66.974	84.265	99.126	117.56	137.56	159.14	182.28	206.99	233.28	.2343	15/64





## Area of Circles

**D = Diameter    Area = .785 D<sup>2</sup>**

Dec.	Frac.	Inches									Dec.	Frac.
		0	1	2	3	4	5	6	7	8		
.2500	1/4	.04909	1.2272	3.9761	8.2958	14.186	21.648	30.680	41.282	53.456	.2500	1/4
.2656	17/64	.05541	1.2577	4.0315	8.3757	14.291	21.777	30.833	41.461	53.659	.2656	17/64
.2812	9/32	.06213	1.2893	4.0873	8.4561	14.396	21.906	30.987	41.639	53.862	.2812	9/32
.2968	19/64	.06922	1.3209	1.1435	8.5368	14.501	22.036	31.141	41.818	54.065	.2968	19/64
.3125	5/16	.07670	1.3530	4.200	8.6179	14.607	22.166	31.296	41.997	54.269	.3125	5/16
.3281	21/64	.08456	1.3854	4.2570	8.6994	14.713	22.297	31.451	42.177	54.473	.3281	21/64
.3437	11/32	.09281	1.1482	4.3143	8.7813	14.819	22.428	31.607	42.357	54.678	.3437	11/32
.3593	23/64	.1014	1.4513	4.3720	8.8636	14.926	22.559	31.763	42.537	54.883	.3593	23/64
.3750	3/8	.1104	1.4849	4.4301	8.9462	15.033	22.691	31.919	42.718	55.088	.3750	3/8
.3906	25/64	.1198	1.5188	4.4886	9.0292	15.141	22.823	32.076	42.899	55.294	.3906	25/64
.4062	13/32	.1296	1.5532	4.5475	9.1126	15.249	22.955	32.233	43.081	55.500	.4062	13/32
.4218	27/64	.1398	1.5879	4.6067	9.1964	15.357	23.088	32.390	43.263	55.707	.4218	27/64
.4375	7/16	.1503	1.6230	4.6664	9.2806	15.466	23.221	32.548	43.445	55.914	.4375	7/16
.4531	29/64	.1613	1.6584	4.7264	9.3652	15.575	23.355	32.706	43.628	56.121	.4531	29/64
.4687	15/32	.1726	1.6943	4.7863	9.4501	15.684	23.489	32.865	43.811	56.329	.4687	15/32
.4843	31/64	.1843	1.7305	4.8476	9.5354	15.794	23.623	33.024	43.995	56.537	.4843	31/64

## Area of Circles

**D = Diameter    Area = .785 D<sup>2</sup>**

Dec.	Frac.	Inches										Dec.	Frac.
		Dia.	9	10	11	12	13	14	15	16	17		
.2500	1/4	67.201	82.516	99.402	117.86	137.89	159.48	182.65	207.39	233.71	.2500	1/4	
.2656	17/64	67.428	82.768	99.678	118.16	138.21	159.83	183.03	207.79	234.13	.2656	17/64	
.2812	9/32	67.655	83.020	99.955	118.46	138.54	160.19	183.40	209.19	234.55	.2812	9/32	
.2968	19/64	67.883	83.272	100.232	118.76	138.86	160.54	183.78	208.59	234.98	.2968	19/64	
.3125	5/16	68.112	83.525	100.509	119.06	139.19	160.89	184.15	208.69	235.40	.3125	5/16	
.3281	21/64	68.341	83.779	100.787	119.37	139.52	161.24	184.53	209.39	235.83	.3281	21/64	
.3437	11/32	68.570	84.032	101.066	119.67	139.84	161.59	194.91	209.79	236.25	.3437	11/32	
.3593	23/64	68.799	84.286	101.344	119.97	140.17	161.94	185.28	210.20	236.68	.3593	23/64	
.3750	3/8	69.029	84.541	101.623	120.28	140.50	162.30	185.66	210.60	237.10	.3750	3/8	
.3906	25/64	69.259	84.796	101.903	120.58	140.83	162.65	186.04	211.00	237.53	.3906	25/64	
.4062	13/32	69.490	85.051	102.182	120.88	141.16	153.00	186.42	211.40	237.96	.4062	13/32	
.4218	27/64	69.721	85.306	102.462	121.19	141.49	163.36	186.79	211.80	238.39	.4218	27/64	
.4375	7/16	69.953	85.562	102.743	121.49	141.82	163.71	187.17	212.21	238.81	.4375	7/16	
.4531	29/64	70.184	85.819	103.024	121.80	142.15	164.06	187.55	212.61	239.24	.4531	29/64	
.4687	15/32	70.417	86.075	103.305	122.11	142.48	164.42	187.93	213.02	239.67	.4687	15/32	
.4843	31/64	70.649	86.333	103.587	122.43	142.81	164.77	188.31	213.42	240.10	.4843	31/64	





## Area of Circles

**D = Diameter    Area = .785 D<sup>2</sup>**

Dec.	Frac.	Inches										Dec.	Frac.
		0	1	2	3	4	5	6	7	8			
.5000	1/2	.1963	1.7671	4.9083	9.6212	15.904	23.758	33.183	44.179	56.745	.5000	1/2	
.5166	33/64	.2088	1.8042	4.9703	9.7072	16.015	23.893	33.343	44.363	56.954	.5156	33/64	
.5312	17/32	.2217	1.8415	5.0322	9.7937	16.126	24.029	33.503	44.548	57.163	.5312	17/32	
.5468	35/64	.2349	1.8793	5.0946	9.8806	16.237	24.165	33.663	44.733	57.373	.5468	35/64	
.5625	9/16	.2485	1.9175	5.1573	9.9678	16.349	24.301	33.824	44.918	57.583	.5625	9/16	
.5781	37/64	.2625	1.9560	5.2203	10.0554	16.461	24.438	33.985	45.104	57.793	.5781	37/64	
.5937	19/32	.2769	1.9949	5.2838	10.1435	16.574	24.575	34.147	45.290	58.004	.5937	19/32	
.6093	39/64	.2916	2.0342	5.3477	10.2318	16.687	24.713	34.309	45.477	58.215	.6093	39/64	
.6250	5/8	.3068	2.0739	5.4119	10.3206	16.800	24.850	34.472	45.664	58.426	.6250	5/8	
.6406	41/64	.3223	2.1140	5.4765	10.4098	16.914	24.989	34.634	45.851	58.638	.6406	41/64	
.6562	21/32	.3382	2.1545	5.5415	10.4994	17.028	25.127	34.798	46.039	58.850	.6562	21/32	
.6718	43/64	.3545	2.1953	5.6069	10.5893	17.142	25.266	34.961	46.227	59.063	.6718	43/64	
.6875	11/16	.3712	2.2365	5.6727	10.6796	17.257	25.406	35.125	46.415	59.276	.6875	11/16	
.7031	45/64	.3883	2.2782	5.7388	10.7703	17.372	25.546	35.289	46.604	59.489	.7031	45/64	
.7187	23/32	.4067	2.3201	5.8054	10.8614	17.488	25.686	35.454	46.793	59.703	.7187	23/32	
.7343	47/64	.4236	2.3623	5.8723	10.9528	17.604	25.826	35.619	46.983	59.917	.7343	47/64	

## Area of Circles

**D = Diameter    Area = .785 D<sup>2</sup>**

Dec.	Frac.	Inches										Dec.	Frac.
		Dia.	9	10	11	12	13	14	15	16	17		
.5000	1/2	70.882	86.590	103.869	122.72	143.14	165.13	188.69	213.82	240.53	.5000	1/2	
.5156	33/64	71.116	86.848	104.151	123.03	143.47	165.49	189.07	214.23	240.96	.5156	33/64	
.5312	17/32	71.349	87.106	104.434	123.33	143.80	165.84	189.45	214.64	241.39	.5312	17/32	
.5468	35/64	71.583	87.365	104.717	123.64	144.13	166.20	189.83	215.04	241.82	.5468	35/64	
.5625	9/16	71.818	87.624	105.001	123.95	144.47	166.56	190.22	215.45	242.25	.5625	9/16	
.5781	37/64	72.053	87.883	105.285	124.26	144.80	166.91	190.60	215.85	242.68	.5781	37/64	
.5937	19/32	72.288	88.143	105.569	124.57	145.13	167.27	190.98	216.26	243.11	.5937	19/32	
.6093	39/64	72.524	88.404	105.804	124.88	145.47	167.63	191.36	216.67	243.54	.6093	39/64	
.6250	5/8	72.760	88.664	106.139	125.19	145.80	167.99	191.75	217.08	243.98	.6250	5/8	
.6406	41/64	72.996	88.925	106.425	125.50	146.14	168.35	192.13	217.48	244.41	.6406	41/64	
.6562	21/32	73.233	89.186	106.711	125.81	146.47	168.71	192.52	217.89	244.84	.6562	21/32	
.6718	43/64	73.470	89.448	106.997	126.12	146.81	169.07	192.90	218.30	245.28	.6718	43/64	
.6875	11/16	73.708	89.710	107.284	126.43	147.14	169.43	193.28	218.71	245.71	.6875	11/16	
.7031	45/64	73.946	89.973	107.571	126.74	147.48	169.79	193.67	219.12	246.14	.7031	45/64	
.7187	23/32	74.184	90.236	107.858	127.05	147.82	170.15	194.06	219.53	246.58	.7187	23/32	
.7343	47/64	74.423	90.499	108.146	127.36	148.15	170.51	194.44	219.94	247.01	.7343	47/64	







## Area of Circles

**D = Diameter    Area = .785 D<sup>2</sup>**

Dec.	Frac.	Inches								Dec.	Frac.	
		0	1	2	3	4	5	6	7			8
.7500	<sup>3</sup> / <sub>4</sub>	.4418	2.4053	5.9396	11.0447	17.721	25.967	35.785	47.173	60.132	.7500	<sup>3</sup> / <sub>4</sub>
.7656	<sup>49</sup> / <sub>64</sub>	.6404	2.4484	6.0073	11.1369	17.837	26.108	35.951	47.363	60.347	.7656	<sup>49</sup> / <sub>64</sub>
.7812	<sup>25</sup> / <sub>32</sub>	.4794	2.4929	6.0753	11.2295	17.954	26.250	36.117	47.554	60.562	.7812	<sup>25</sup> / <sub>32</sub>
.7968	<sup>51</sup> / <sub>64</sub>	.4987	2.5359	6.1438	11.3236	18.072	26.392	36.283	47.745	60.778	.7968	<sup>51</sup> / <sub>64</sub>
.8125	<sup>13</sup> / <sub>16</sub>	.5185	2.5802	6.2126	11.4159	18.190	26.535	36.450	47.937	60.994	.8125	<sup>13</sup> / <sub>16</sub>
.8281	<sup>53</sup> / <sub>64</sub>	.5386	2.6248	6.2819	11.5096	18.308	26.678	36.618	48.129	61.211	.8281	<sup>53</sup> / <sub>64</sub>
.8437	<sup>27</sup> / <sub>32</sub>	.5591	2.6699	6.3515	11.6038	18.427	26.821	36.787	48.321	61.427	.8437	<sup>27</sup> / <sub>32</sub>
.8593	<sup>55</sup> / <sub>64</sub>	.5800	2.7153	6.4215	11.6983	18.546	26.964	36.954	48.514	61.645	.8593	<sup>55</sup> / <sub>64</sub>
.8750	<sup>7</sup> / <sub>8</sub>	.6013	2.7612	6.4918	11.7933	18.665	27.109	37.122	48.707	61.862	.8750	<sup>7</sup> / <sub>8</sub>
.8906	<sup>57</sup> / <sub>64</sub>	.6230	2.8074	6.5626	11.8885	18.785	27.252	39.291	48.900	62.080	.8906	<sup>57</sup> / <sub>64</sub>
.9062	<sup>29</sup> / <sub>32</sub>	.6450	2.8540	6.6337	11.9842	18.906	27.398	37.461	49.094	62.299	.9062	<sup>29</sup> / <sub>32</sub>
.9218	<sup>59</sup> / <sub>64</sub>	.6675	2.9010	6.7052	12.0803	19.026	27.543	37.630	49.288	62.518	.9218	<sup>59</sup> / <sub>64</sub>
.9375	<sup>15</sup> / <sub>16</sub>	.6903	2.9483	6.7771	12.1768	19.147	27.688	37.800	49.483	62.737	.9375	<sup>15</sup> / <sub>16</sub>
.9531	<sup>61</sup> / <sub>64</sub>	.7135	2.9961	6.8494	12.2736	19.268	27.834	37.971	49.678	62.956	.9531	<sup>61</sup> / <sub>64</sub>
.9687	<sup>31</sup> / <sub>32</sub>	.7371	3.0442	6.9221	12.3708	19.390	27.981	38.142	49.874	63.176	.9687	<sup>31</sup> / <sub>32</sub>
.9843	<sup>63</sup> / <sub>64</sub>	.7610	3.0927	6.9952	12.4684	19.512	28.127	38.313	50.069	63.396	.9843	<sup>63</sup> / <sub>64</sub>

## Area of Circles

**D = Diameter    Area = .785 D<sup>2</sup>**

Dec.	Frac.	Inches										Dec.	Frac.
		Dia.	9	10	11	12	13	14	15	16	17		
.7500	<sup>3</sup> / <sub>4</sub>	74.662	74.662	90.763	108.434	127.68	148.49	170.87	194.83	220.35	247.45	.7500	<sup>3</sup> / <sub>4</sub>
.7656	<sup>49</sup> / <sub>64</sub>	74.901	74.901	91.027	108.723	127.99	148.83	171.24	195.21	220.76	247.89	.7656	<sup>49</sup> / <sub>64</sub>
.7812	<sup>25</sup> / <sub>32</sub>	75.141	75.141	91.291	109.012	128.30	149.17	171.60	195.60	221.18	248.32	.7812	<sup>25</sup> / <sub>32</sub>
.7968	<sup>51</sup> / <sub>64</sub>	75.382	75.382	91.556	109.301	128.62	149.50	171.96	195.99	221.59	248.76	.7968	<sup>51</sup> / <sub>64</sub>
.8125	<sup>13</sup> / <sub>16</sub>	75.622	75.622	91.821	109.591	128.93	149.84	172.32	196.38	222.00	249.20	.8125	<sup>13</sup> / <sub>16</sub>
.8281	<sup>53</sup> / <sub>64</sub>	75.863	75.863	92.087	109.881	129.25	150.18	172.69	196.77	222.41	249.63	.8281	<sup>53</sup> / <sub>64</sub>
.8437	<sup>27</sup> / <sub>32</sub>	76.105	76.105	92.353	110.171	129.56	150.52	173.05	197.15	222.83	250.07	.8437	<sup>27</sup> / <sub>32</sub>
.8593	<sup>55</sup> / <sub>64</sub>	76.346	76.346	92.619	110.462	129.88	150.86	173.42	197.54	223.24	250.51	.8593	<sup>55</sup> / <sub>64</sub>
.8750	<sup>7</sup> / <sub>8</sub>	76.589	76.589	92.886	110.753	130.19	151.20	173.78	197.93	223.65	250.95	.8750	<sup>7</sup> / <sub>8</sub>
.8906	<sup>57</sup> / <sub>64</sub>	76.831	76.831	93.153	111.045	130.51	151.54	174.15	198.32	224.07	251.39	.8906	<sup>57</sup> / <sub>64</sub>
.9062	<sup>29</sup> / <sub>32</sub>	77.074	77.074	93.420	111.337	130.82	151.88	174.51	198.71	224.48	251.83	.9062	<sup>29</sup> / <sub>32</sub>
.9218	<sup>59</sup> / <sub>64</sub>	77.317	77.317	93.688	111.630	131.14	152.22	174.88	199.10	224.90	252.26	.9218	<sup>59</sup> / <sub>64</sub>
.9375	<sup>15</sup> / <sub>16</sub>	77.561	77.561	93.956	111.922	131.46	152.57	175.25	199.49	225.31	252.70	.9375	<sup>15</sup> / <sub>16</sub>
.9531	<sup>61</sup> / <sub>64</sub>	77.805	77.805	94.225	112.215	131.78	152.91	175.61	119.89	225.73	253.15	.9531	<sup>61</sup> / <sub>64</sub>
.9687	<sup>31</sup> / <sub>32</sub>	78.050	78.050	94.494	112.509	132.09	153.25	175.98	200.28	226.15	253.59	.9687	<sup>31</sup> / <sub>32</sub>
.9843	<sup>63</sup> / <sub>64</sub>	78.295	78.295	94.763	112.803	132.41	153.59	176.35	200.67	226.56	254.03	.9843	<sup>63</sup> / <sub>64</sub>





## Area of Circles

$D = \text{Diameter}$      $\text{Area} = .785 D^2$

Diameter (cm)	Centimeters																			Diameter (cm)	
	0	1	2	3	4	5	6	7	8	9	10	11	12	13	14	15	16	17	18		19
0	0	0.78540	3.14159	7.06858	12.5664	19.350	28.2743	38.4845	50.2655	63.6173	78.5398	95.0332	113.097	132.732	153.938	176.715	201.062	226.980	254.469	283.529	0
0.1	0.00785	0.95033	3.16360	7.54768	13.2025	20.282	29.2247	39.5919	51.5300	65.0388	80.1185	96.7689	114.990	134.782	156.145	179.079	203.583	229.658	257.304	286.521	0.1
0.2	0.03141	1.13097	3.80133	8.04248	13.8544	21.372	30.1907	40.7150	52.8102	66.4761	81.7128	98.5203	116.899	136.848	158.368	181.458	206.120	232.352	260.155	289.529	0.2
0.3	0.07069	1.32732	4.15476	8.55299	14.5220	22.618	31.1725	41.8539	54.1061	67.9291	83.3229	100.287	118.823	138.929	160.606	183.854	208.672	235.062	263.022	292.553	0.3
0.4	0.12566	1.53938	4.52389	9.07920	15.2053	22.022	32.1699	43.0084	55.4177	69.3978	84.9487	102.070	120.763	141.026	162.360	186.265	211.241	237.787	265.904	295.592	0.4
0.5	0.19635	1.76715	4.90874	9.62113	15.9043	23.583	33.1831	44.1786	56.7450	70.8822	86.5901	103.869	122.718	143.139	165.130	188.692	213.825	240.528	268.803	298.648	0.5
0.6	0.28274	2.01062	5.30929	10.1788	16.6190	24.301	34.2119	45.3646	58.0880	72.3823	88.2473	105.683	124.690	145.267	167.415	191.134	216.424	243.285	271.716	301.719	0.6
0.7	0.38485	2.26980	5.72555	10.7521	17.3494	25.176	35.2565	46.5663	59.4468	73.8981	89.9202	107.513	126.677	147.411	165.717	193.593	219.040	246.057	274.646	304.805	0.7
0.8	0.50265	2.54469	6.15752	11.3411	18.0956	26.208	36.3168	47.7836	60.8212	75.4296	91.6088	109.359	128.680	149.571	167.034	196.067	221.671	248.846	277.591	307.907	0.8
0.9	0.63617	2.83529	6.60520	11.9459	18.8574	27.397	37.3928	49.0167	60.2114	76.9769	193.3132	111.2201	130.698	151.747	174.366	198.557	224.318	251.649	280.552	311.026	0.9

## Area of Circles

$D = \text{Diameter}$      $\text{Area} = .785 D^2$

Diameter (cm)	Centimeters																			Diameter (cm)	
	20	21	22	23	24	25	26	27	28	29	30	31	32	33	34	35	36	37	38		39
0	314.159	346.361	380.133	415.476	452.389	490.874	530.929	572.555	615.752	660.520	0										
0.1	317.309	349.667	383.596	419.096	456.167	494.809	535.021	576.804	620.158	665.083	0.1										
0.2	320.474	352.989	387.076	422.733	459.961	498.759	539.129	581.069	624.580	669.662	0.2										
0.3	323.655	356.327	390.571	426.385	463.770	502.726	543.252	585.349	629.018	674.256	0.3										
0.4	326.851	359.681	394.081	430.053	467.595	506.707	547.391	589.646	633.471	678.867	0.4										
0.5	330.064	363.050	397.608	433.736	471.435	510.705	551.546	593.957	637.940	683.493	0.5										
0.6	333.292	366.435	401.150	437.435	475.292	514.719	555.716	598.285	642.424	688.134	0.6										
0.7	336.535	369.836	404.708	441.150	479.164	518.748	559.902	602.628	646.925	692.792	0.7										
0.8	339.795	373.253	408.281	444.881	483.051	522.792	564.104	606.987	651.441	697.465	0.8										
0.9	343.070	376.685	411.871	448.627	486.955	526.853	568.322	611.362	655.972	702.154	0.9										
Diameter (cm)	Centimeters																			Diameter (cm)	
0	30	31	32	33	34	35	36	37	38	39	0	30	31	32	33	34	35	36	37	38	39
0	706.858	754.768	804.248	855.299	907.920	962.113	1017.88	1075.21	1134.11	1194.59	0										
0.1	711.579	759.645	809.282	860.490	913.269	967.618	1023.54	1081.03	1140.09	1200.72	0.1										
0.2	716.315	764.538	814.332	865.697	918.633	973.140	1029.22	1086.87	1146.08	1206.87	0.2										
0.3	721.066	769.447	819.398	870.920	914.013	978.677	1034.91	1092.72	1152.09	1213.04	0.3										
0.4	725.834	774.371	824.480	876.159	919.409	984.230	1040.62	1098.58	1158.12	1219.22	0.4										
0.5	730.617	779.311	829.577	881.413	934.820	989.798	1046.35	1104.47	1164.16	1225.42	0.5										
0.6	735.415	784.267	834.690	886.683	940.247	995.382	1052.09	1110.36	1170.21	1231.63	0.6										
0.7	740.230	789.239	839.818	891.969	945.690	1000.98	1057.84	1116.28	1176.28	1237.86	0.7										
0.8	745.060	794.226	844.963	897.270	951.149	1006.60	1063.62	1122.21	1182.37	1244.10	0.8										
0.9	749.906	799.229	850.123	902.587	956.623	1012.23	1069.41	1128.15	1188.47	1250.36	0.9										





## Area of Circles

$D = \text{Diameter}$      $\text{Area} = .785 D^2$

Diameter (cm)	Centimeters										Diameter (cm)
	40	41	42	43	44	45	46	47	48	49	
0	1256.64	1320.25	1385.44	1452.20	1520.53	1590.43	1661.90	1734.94	1809.56	1885.74	0
0.1	1262.93	1326.70	1392.05	1458.96	1527.45	1597.51	1669.14	1742.34	1817.11	1893.45	0.1
0.2	1269.23	1333.17	1398.67	1465.74	1534.39	1604.60	1676.39	1749.74	1824.67	1901.17	0.2
0.3	1275.56	1339.65	1405.31	1472.54	1541.34	1611.71	1683.65	1757.16	1832.25	1908.90	0.3
0.4	1281.90	1346.14	1411.96	1479.34	1548.30	1618.83	1690.93	1764.60	1839.84	1916.65	0.4
0.5	1288.25	1352.65	1418.63	1486.17	1555.28	1625.97	1698.23	1772.05	1847.45	1924.42	0.5
0.6	1294.62	1359.18	1425.31	1493.01	1562.28	1633.13	1705.54	1779.52	1855.08	1932.21	0.6
0.7	1301.00	1365.72	1432.01	1499.87	1569.30	1640.30	1712.87	1787.01	1862.72	1940.00	0.7
0.8	1307.41	1372.28	1438.72	1506.74	1576.33	1647.48	1720.21	1794.51	1870.38	1947.82	0.8
0.9	1313.82	1378.85	1445.45	1513.63	1583.37	1654.68	1727.57	1802.03	1878.05	1955.65	0.9

## Conversion Factors

Multiply	By	To Obtain
Acre	43,560.	Square Feet
Acre	4,047.	Square Meters
Acre	160.	Square Rods
Acre	5,645.4	Sqaure Varas (Texas)
Acre	.4047	Hectares
Acre Foot	7,758.	Barrels
Atmospheres	76.0	Cms. of Mercury
Atmospheres	760.0	Millimeters of Mercury
Atmospheres	29.92	Inches of Mercury
Atmospheres	33.93	Feet of Water
Atmospheres	1.0333	Kgs./sq. Cm.
Atmospheres	14.70	Lbs./sq. Inch
Atmospheres	1.058	Tons/sq. Ft.
Barrel	5.6146	Cubic Feet
Barrel	.15897	Cubic Meters
Barrels-Oil	42.	Gallons-Oil
Barrel of Water	.1588	Metric Ton
Barrel (36° A.P.I.)	.1342	Metric Ton
Barrel per Hour	.0936	Cu. Ft. per Minute
Barrel per Hour	.700	Gallon per Minute
Barrel per Hour	2.695	Cu. In. per Second
Barrel per Day	.02917	Gallon per Minute
Bars	.9869	Atmospheres
Bars	2089	Lbs./sq. Foot
Bars	14.50	Lbs./sq. Inch
British Thermal Units	0.2520	Kilo-Calories
British Thermal Units	.2931	Watt Hour
British Thermal Units	778.2	Foot-Lbs.
British Thermal Units	.0003930	Horsepower-Hours
British Thermal Units	107.6	Kilogram-meters
British Thermal Units	.0002931	Kilowatt-hours
B.T.U./min.	12.96	Foot-lbs./sec.
B.T.U./min.	.02358	Horsepower
B.T.U./min.	.01758	Kilowatts
B.T.U./min.	17.58	Watts
Centares (Centaires)	1.	Square Meters
Centigrams	.01	Grams
Centiliters	.01	Liters
Centimeters	.3937	Inches
Centimeters	.01	Meters
Centimeters	10.	Millimeters
Centimeters of Mercury	.01316	Atmospheres
Centimeters of Mercury	.4465	Feet of Water
Centimeters of Mercury	1365.9	Kgs./sq. Meter
Centimeters of Mercury	27.85	Lbs./sq. Ft.
Centimeters of Mercury	.1934	Lbs./sq. Inch
Centimeters/Second	1.969	Feet/Min.
Centimeters/Second	.03281	Feet/Sec.
Centimeters/Second	.036	Kilometers/Hrs.



## Conversion Factors

Multiply	By	To Obtain
Centimeters/Second	.6	Meters/Min.
Centimeters/Second	.02237	Miles/Hrs.
Centimeters/Second	.0003728	Miles/Min.
Centimeters/Second/Second	.03281	Feet/Sec. Sec.
Chain	66.00	Feet
Chain	4.00	Rods
Cubic Centimeters	.00003531	Cubic Feet
Cubic Centimeters	.06102	Cubic Inches
Cubic Centimeters	.0000010	Cubic Meters
Cubic Centimeters	.000001308	Cubic Yards
Cubic Centimeters	.0002642	Gallons (U.S.)
Cubic Centimeters	.001	Liters
Cubic Centimeters	.002113	Pints (Liq.)
Cubic Centimeters	.001057	Quarts (Liq.)
Cubic Feet	.1781	Barrels
Cubic Feet	28316.	Cubic Cms.
Cubic Feet	1728.	Cubic Inches
Cubic Feet	.02832	Cubic Meters
Cubic Feet	.03704	Cubic Yards
Cubic Feet	7.48052	Gallons
Cubic Feet	28.32	Liters
Cubic Feet	59.84	Pints (Liq.)
Cubic Feet	29.92	Quarts (Liq.)
Cubic Feet/Minute	471.9	Cubic Cm./Sec.
Cubic Feet/Minute	.1247	Gallons/Sec.
Cubic Feet/Minute	.4719	Liters/Sec.
Cubic Feet/Minute	62.43	Lbs. of Water/Min.
Cubic Feet/Minute	10.686	Barrels per Hour
Cubic Feet/Minute	28.800	Cubic In. per Sec.
Cubic Feet/Second	.646317	Million Gals./Day
Cubic Feet/Second	448.831	Gallons/Minute
Cubic Inches	16.39	Cubic Centimeters
Cubic Inches	.0005787	Cubic Feet
Cubic Inches	.00001639	Cubic Meters
Cubic Inches	.00002143	Cubic Yards
Cubic Inches	.004329	Gallons (U.S.)
Cubic Inches	.01639	Liters
Cubic Inches	.03463	Pints (Liq.)
Cubic Inches	.01732	Quarts (Liq.)
Cubic Meters	6.2898	Barrels
Cubic Meters	1,000,000.	Cubic Centimeters
Cubic Meters	35.31	Cubic Feet
Cubic Meters	61,023.	Cubic Inches
Cubic Meters	1.308	Cubic Yards
Cubic Meters	264.2	Gallons (U.S.)
Cubic Meters	1,000.	Liters
Cubic Meters	2,113.	Pints (Liq.)
Cubic Meters	1,057.	Quarts (Liq.)



## Conversion Factors

Multiply	By	To Obtain
Cubic Yards	4.8089	Barrels
Cubic Yards	764,555.	Cubic Centimeters
Cubic Yards	27.	Cubic Feet
Cubic Yards	46,656	Cubic Inches
Cubic Yards	0.7646	Cubic Meters
Cubic Yards	202.0	Gallons (U.S.)
Cubic Yards	764.6	Liters
Cubic Yards	1,616.	Pints (Liq.)
Cubic Yards	807.9	Quarts (Liq.)
Cubic Yards/Min.	.45	Cubic Feet/Sec.
Cubic Yards/Min.	3.366	Gallon/Sec.
Cubic Yards/Min.	12.74	Liters/Sec.
Decigrams	.1	Grams
Deciliters	.1	Liters
Decimeters	.1	Meters
Degrees (angle)	60.	Minutes
Degrees (angle)	.01745	Radians
Degrees (angle)	3600.	Seconds
Degrees/Sec.	.01745	Radians/Sec.
Degrees/Sec.	.1667	Revolutions/Min.
Degrees/Sec.	.002778	Revolutions/Sec.
Dekagrams	10.	Gram
Dekaliters	10.	Liters
Dekameters	10.	Meters
Drams	27.34375	Grains
Drams	.0625	Ounces
Drams	1.771845	Grams
Fathoms	6.	Feet
Feet	30.48	Centimeters
Feet	12.	Inches
Feet	.3048	Meters
Feet	.3600	Varas (Texas)
Feet	1/3	Yards
Feet of Water	.02950	Atmospheres
Feet of Water	.8818	Inches of Mercury
Feet of Water	.03045	Kgs./Sq. Cm.
Feet of Water	62.37	Lbs./Sq. Ft.
Feet of Water	.4331	Lbs./Sq.In.
Feet/Min.	.5080	Centimeter/Sec.
Feet/Min.	.01667	Feet/Sec.
Feet Min.	.01829	Kilometers/Hr.
Feet Min.	.3048	Meters/Min.
Feet Min.	.01136	Miles Hr.
Feet/Sec.	.68182	Miles per Hour
Feet/Sec./Sec.	30.48	Gms./Sec./Sec.
Feet/Sec./Sec.	.3048	Meters/Sec./Sec.





## Conversion Factors

Multiply	By	To Obtain
Foot-pounds	.001286	British Thermal Units
Foot-pounds	.0000005050	Horsepower-hrs.
Foot-pounds	.0003241	Kilo-calories
Foot-pounds	.1383	Kilogram-meters
Foot-pounds	.0000003766	Kilowatt-hrs
Foot-pounds/min.	.001286	British Thermal Units/min.
Foot-pounds/min.	.01667	Foot-pounds/sec.
Foot-pounds/min.	.00003030	Horsepower
Foot-pounds/min.	.0003241	Kg.-calories/min.
Foot-pounds/min.	.00002260	Kilowatts
Foot-pounds/sec.	.07710	British Thermal Units/min.
Foot-pounds/sec.	.001818	Horsepower
Foot-pounds/sec.	.01943	Kilo-calories/min.
Foot-pounds/sec.	.001356	Kilowatts
Gallons (U.S.)	.02381	Barrel
Gallons (U.S.)	.83267	Gallons (imperial)
Gallons	3,785.	Cubic Centimeters
Gallons	.1337	Cubic Feet
Gallons	231.	Cubic Inches
Gallons	.003785	Cubic Meters
Gallons	.00495	Cubic Yards
Gallons	3.785	Liters
Gallons	8.	Pints (liq.)
Gallons	4.	Quarts (Liq.)
Gallons (imperial)	1.20095	Gallons (U.S.)
Gallons (imperial)	277.419	Cubic Inches
Gallons Water	8.3453	Pounds of Water
Gallons/min.	1.429	Barrels per Hour
Gallons/min.	.1337	Cu. Ft. per Minute
Gallons/min.	34.286	Barrels per Day
Gallons/min.	.06309	Liters/sec.
Gallons/min.	8.0208	Cu. Ft./hr.
Gallons/min.	.002228	Cu. Ft./sec.
Gallons of Water/min	6.0086	Tons Water/24 hrs.
Grains (troy)	1.	Grains (avoir.)
Grains (troy)	.06480	Grams
Grains (troy)	.04167	Pennyweights (troy)
Grains (troy)	.0020833	Ounces (troy)
Grains/U.S. gal.	17.118	Parts/million
Grains/U.S. gal.	142.86	Lbs./million gal.
Grains/imperial gal.	14.286	Parts/million
Grams	980.7	Dynes
Grams	15.43	Grains
Grams	.001	Kilograms
Grams	1,000.	Milligrams
Grams	.03527	Ounces (avoir.)
Grams	.03215	Ounces (troy)



## Conversion Factors

Multiply	By	To Obtain
Grams/cm.	.0056	Pounds/inch
Grams/cu. cm.	62.43	Pounds/cubic foot
Grams/cu. cm.	.03613	Pounds/cubic inch
Grams/liter	58.417	Grains/gal.
Grams/liter	8.345	Pounds/1000 gals.
Grams/liter	.062427	Pounds/cubic foot
Grams/liter	1,000.	Parts/million
Hectare	2.471	Acres
Hectare	.010	Square Kilometer
Hectograms	100.	Grams
Hectoliters	100.	Liters
Hectowatts	100.	Watts
Horsepower	42.41	British Thermal units/min.
Horsepower	33,000.	Foot-lbs/min.
Horsepower	550.	Foot-lbs/sec.
Horsepower	1.014	Horsepower (Metric)
Horsepower	10.69	Kilo-calories/min.
Horsepower	.7457	Kilowatts
Horsepower	745.7	Watts
Horsepower (boiler)	33,479.	British Thermal units/hr.
Horsepower (boiler)	9.803	Kilowatts
Horsepower-hours	2,544.	British Thermal Units
Horsepower-hours	1,980,000.	Foot-lbs.
Horsepower-hours	641.7	Kilo-calorie
Horsepower-hours	273,743.	Kilogram-meters
Horsepower-hours	.7457	Kilowatt-hours
Inches	2.540	Centimeters
Inches of Mercury	.03342	Atmospheres
Inches of Mercury	1.134	Feet of Water
Inches of Mercury	.03453	Kgs./Sq. cm.
Inches of Mercury	70.73	Lbs./Sq. Ft.
Inches of Mercury	.4912	Lbs./Sq. In.
Inches of Water	.002456	Atmospheres
Inches of Water	.07348	Inches of Mercury
Inches of Water	.002537	Kgs./Sq. Cm.
Inches of Water	.5774	Ounces/Sq. Inch
Inches of Water	5.197	Lbs./Sq. Ft.
Inches of Water	.03609	Lbs./Sq. Inch
Kilograms	980.665.	Dynes
Kilograms	2.205	Lbs.
Kilograms	.001102	Tons (short)
Kilograms	1,000.	Grams



## Conversion Factors

Multiply	By	To Obtain
Kilograms-meter	7.233	Ft.-Lbs.
Kilograms-meter	.6720	Lbs./Ft.
Kilograms/sq. cm.	.9678	Atmospheres
Kilograms/sq. cm.	32.84	Feet of Water
Kilograms/sq. cm.	28.96	Inches of Mercury
Kilograms/sq. cm.	2,048.	Lbs./Sq. Foot
Kilograms/sq. cm.	14.22	Lbs./Sq. Inch
Kgs./sq. millimeter	1,000,000.	Kgs./sq. meter
Kiloliters	1,000	Liters
Kilometers	100,000	Centimeters
Kilometers	3281.	Feet
Kilometers	1,000	Meters
Kilometers	.6214	Miles
Kilometers	.5400	Miles (nautical)
Kilometers	1,094.	Yards
Kilometers/hr.	27.78	Centimeters/sec.
Kilometers/hr.	54.68	Feet/min.
Kilometers/hr.	.9113	Feet/sec
Kilometers/hr.	.5396	Knots
Kilometers/hr.	16.67	Meters/min.
Kilometers/hr.	.6214	Miles/hr.
Kms./hr./sec.	27.78	Cms./sec./sec.
Kms./hr./sec.	.9113	Ft./sec./sec.
Kms./hr./sec.	.2778	Meters/sec./sec.
Kilowatts	56.87	British Thermal Units/min.
Kilowatts	44,250.	Foot-lbs./min.
Kilowatts	737.6	Foot-lbs./sec.
Kilowatts	1.341	Horsepower
Kilowatts	14.33	Kilo-calories/min.
Kilowatts	1,000	Watts
Kilowatt-hours	3,412	British Thermal Units
Kilowatt-hours	2,655,000.	Foot-lbs.
Kilowatt-hours	1.341	Horsepower-hrs.
Kilowatt-hours	859.8	Kilo-calories
Kilowatt-hours	367,100	Kilogram-meters
Knot	1.	Nautical Miles per Hour
Knot	1.151	Statute Mile per Hour
Link (Surveyor's)	7.92	Inches
Liters	1,000.	Cubic Centimeters
Liters	.03531	Cubic Feet
Liters	61.02	Cubic Inches
Liters	.001	Cubic Meters
Liters	.001308	Cubic Yards
Liters	.2642	Gallons (U.S.)
Liters	.2200	Gallons (Imperial)
Liters	2.113	Pints (Liq.)
Liters	1.057	Quarts (Liq.)
Liters/min.	.0005886	Cubic Ft./Sec.



## Conversion Factors

Multiply	By	To Obtain
$\frac{\text{Width (in.)} \times \text{thickness (in.)}}{12}$	Length (ft.)	Board Feet
Meters	100.	Centimeters
Meters	3.281	Feet
Meters	39.37	Inches
Meters	.001	Kilometers
Meters	1,000.	Millimeters
Meters	1.094	Yards
Meters/min.	1.667	Centimeters/sec.
Meters/min.	3.281	Feet/min.
Meters/min.	.05468	Feet/sec.
Meters/min.	.06	Kilometers/hr.
Meters/min.	.03728	Miles/hr.
Meters/sec.	196.8	Feet/min.
Meters/sec.	3.281	Feet/sec.
Meters/sec.	3.6	Kilometers/hr.
Meters/sec.	.06	Kilometers/min.
Meters/sec.	2.237	Miles/hr.
Meters/sec.	.03728	Miles/min.
Microns	.000010	Meters
Miles	160,900.	Centimeters
Miles	5,280.	Feet
Miles	1.609	Kilometers
Miles	1,760.	Yards
Miles	1,900.8	Varas (Texas)
Mile (nautical)	6076.12	Feet
Mile (nautical)	1.15	Mile (statute)
Miles/hr.	44.70	Centimeters/sec.
Miles/hr.	88.	Feet/min.
Miles/hr.	1.467	Feet/sec.
Miles/hr.	1.609	Kilometers/hrs.
Miles/hr.	.8690	Knots
Miles/hr.	26.82	Meters/min.
Miles/min.	2,682	Centimeters/sec.
Miles/min.	88.	Feet/sec.
Miles/min.	1.609	Kilometers/min.
Miles/min.	60.	Miles/hr.
Milliers	1,000.	Kilograms
Milligrams	.0010	Grams
Milliliters	.0010	Liters
Millimeters	.1	Centimeters
Millimeters	.03937	Inches
Milligrams/liter	1.	Parts/million
Million gals./day	1.54723	Cubic feet/sec.



## Conversion Factors

Multiply	By	To Obtain
Miner's inches	1.5	Cubic ft./min.
Minutes (angle)	.0002909	Radians
Ounces	16.	Drams
Ounces	437.5	Grains
Ounces	.0625	Pounds
Ounces	28.349523	Grams
Ounces	.9115	Ounces (troy)
Ounces	.0000279	Tons (long)
Ounces	.00002835	Tons (metric)
Ounces, troy	480.	Grains
Ounces, troy	20.	Pennyweights (troy)
Ounces, troy	.08333	Pounds (troy)
Ounces, troy	31.103475	Grams
Ounces, troy	1.09714	Ounces (avoir.)
Ounces (fluid)	1.805	Cubic Inches
Ounces (fluid)	.02957	Liters
Ounces/sq. inch	.0625	Lbs./sq. in.
Parts/million	.0584	Grains/U.S. Gal.
Parts/million	.07016	Grains/Imperial Gal.
Parts/million	8.345	Lbs./million gal.
Pennyweights (troy)	24.	Grains
Pennyweights (troy)	1.55517	Grams
Pennyweights (troy)	.05	Ounces (troy)
Pennyweights (troy)	.0041667	Pounds (troy)
Pounds	16.	Ounces
Pounds	256.	Drams
Pounds	7,000.	Grains
Pounds	.0005	Tons (short)
Pounds	453.5924	Grams
Pounds	1.21528	Pounds (troy)
Pounds	14.5833	Ounces (troy)
Pounds (troy)	5760.	Grains
Pounds (troy)	240.	Pennyweights (troy)
Pounds (troy)	12.	Ounces (troy)
Pounds (troy)	373.24177	Grams
Pounds (troy)	.822857	Pounds (avoir.)
Pounds (troy)	13.1657	Ounces (avoir.)
Pounds (troy)	.00036735	Tons (long)
Pounds (troy)	.00041143	Tons (short)
Pounds (troy)	.00037324	Tons (metric)
Pounds of water	.01602	Cubic feet
Pounds of water	27.68	Cubic inches
Pounds of water	.1198	Gallons
Pounds/cubic foot	.01602	Grams/cubic cm.
Pounds/cubic foot	16.02	Kgs./cubic meter
Pounds/cubic foot	.0005787	Lbs./cubic inch



## Conversion Factors

Multiply	By	To Obtain
Pounds/cubic inch	27.68	Grams/cubic cm.
Pounds/cubic inch	27,680.	Kgs./cubic meter
Pounds/cubic inch	1,728.	Lbs./cubic foot
Pounds of water/min.	.000267	Cubic ft./sec.
Pounds/foot	1.488	Kgs./meter
Pounds/gallon	0.1198	Grams/cubic cm.
Pounds/inch	178.6	Grams/cm.
Pounds/sq. foot	.01602	Feet of water
Pounds/sq. foot	.0004883	Kgs./sq. cm.
Pounds/sq. foot	.006945	Pounds/sq. inch
Pounds/sq. inch	.06804	Atmospheres
Pounds/sq. inch	2.307	Feet of water
Pounds/sq. inch	2.036	Inches of Mercury
Pounds/sq. inch	.07031	Kgs./sq. cm.
Quarts (dry)	67.20	Cubic inches
Quarts (liquid)	57.75	Cubic inches
Quarts (liquid)	.946	Liter
Quintal	.50802	CWT (hundred weight)
Quintal (Argentina)	101.28	Pounds
Quintal (Brazil)	129.54	Pounds
Quintal (Castile, Peru)	101.43	Pounds
Quintal (Chile)	101.41	Pounds
Quintal (Mexico)	101.47	Pounds
Quintal (metric)	220.46	Pounds
Rod	16.5	Feet
Rod	25.0	Links
Square centimeter	.1550	Square inch
Square foot	.0929	Square meter
Square foot	.1296	Square vara (Texas)
Square inch	6.452	Square centimeters
Square kilometer	.3861	Square mile
Square meter	10.76	Square feet
Square mile	2.590	Square kilometers
Square vara (Texas)	7.716	Square feet
Square mile	640.	Acre
Temp. (°C.) + 273	1.	Abs. temp. (°C.)
Temp. (°C.) + 17.78	1.8	Temp. (°F.)
Temp. (°F.) + 460	1.	Abs. temp. (°F.)
Temp. (°F.) -32	.5555	Temp. (°C.)
Tons (long)	1,016.	Kilograms
Tons (long)	2,240.	Pounds
Tons (long)	1.12000	Tons (short)
Tons (metric)	1,000.	Kilograms
Tons (metric)	2,205.	Pounds



## Temperature Conversion of Fahrenheit to Centigrade

Fahrenheit	Centigrade	Fahrenheit	Centigrade	Fahrenheit	Centigrade
+300°	+148.89°	+180°	+82.22°	+60°	+15.56°
+295°	+146.11°	+175°	+79.44°	+55°	+12.78°
+290°	+143.33°	+170°	+76.67°	+50°	+10.00°
+285°	+140.55°	+165°	+73.89°	+45°	+7.22°
+280°	+137.78°	+160°	+71.11°	+40°	+4.44°
+275°	+135.00°	+155°	+68.33°	+35°	+1.67°
+270°	+132.22°	+150°	+65.55°	+30°	-1.11°
+265°	+129.44°	+145°	+62.78°	+25°	-3.89°
+260°	+126.67°	+140°	+60.00°	+20°	-6.67°
+255°	+123.89°	+135°	+57.22°	+15°	-9.44°
+250°	+121.11°	+130°	+54.44°	+10°	-12.22°
+245°	+118.33°	+125°	+51.67°	+5°	-15.00°
+240°	+115.55°	+120°	+48.89°	0°	-17.78°
+235°	+112.78°	+115°	+46.11°	-5°	-20.56°
+230°	+110.00°	+110°	+43.33°	-10°	-23.33°
+225°	+107.22°	+105°	+40.56°	-15°	-26.11°
+220°	+104.44°	+100°	+37.78°	-20°	-28.89°
+215°	+101.67°	+90°	+35.00°	-25°	-31.67°
+210°	+98.89°	+90°	+32.22°	-30°	-34.44°
+205°	+96.11°	+85°	+29.44°	-35°	-37.22°
+200°	+93.33°	+80°	+26.67°	-40°	-40.00°
+195°	+90.55°	+75°	+23.89°	-45°	-42.78°
+190°	+87.78°	+70°	+21.11°	-50°	-45.56°
+185°	+85.00°	+65°	+18.33°		

### Formulas for Conversion of Fahrenheit and Centigrade Temperature Readings

$$^{\circ}\text{F} = \frac{[^{\circ}\text{C} \times 9]}{5} + 32$$

$$^{\circ}\text{C} = \frac{[^{\circ}\text{F} - 32]}{9} \times 5$$



Copyright ©2000  
Schlumberger  
All Rights Reserved

Printed in Canada

**Schlumberger**