

CHAPTER THREE

Force and Stress

3.1	Introduction	40	3.9	Mean Stress and Deviatoric Stress	52
3.2	Units and Fundamental Quantities	42	3.10	The Stress Tensor	53
3.3	Force	43	3.11	A Brief Summary of Stress	54
3.4	Stress	44	3.12	Stress Trajectories and Stress Fields	55
3.5	Two-Dimensional Stress: Normal Stress and Shear Stress	44	3.13	Methods of Stress Measurement	56
3.6	Three-Dimensional Stress: Principal Planes and Principal Stresses	45	3.13.1	Present-Day Stress	56
	3.6.1 Stress at a Point	46	3.13.2	Paleostress	57
	3.6.2 The Components of Stress	46	3.13.3	Stress in Earth	57
	3.6.3 Stress States	47	3.14	Closing Remarks	60
3.7	Deriving Some Stress Relationships	48		Additional Reading	60
3.8	Mohr Diagram for Stress	49			
	3.8.1 Constructing the Mohr Diagram	50			
	3.8.2 Some Common Stress States	51			

3.1 INTRODUCTION

We frequently use the words force and stress in casual conversation. Stress from yet another deadline, a test, or maybe an argument with a roommate or spouse. Appropriate force is applied to reach our goal, and so on. In science, however, these terms have very specific meanings. For example, the force of gravity keeps us on the Earth's surface and the force of impact destroys our car. Like us, rocks experience the pull of gravity, and forces arising from plate interactions result in a range of geologic structures, from microfibrils to mountain ranges (Figure 3.1). In this chapter we begin with the fundamentals of force and stress, followed by a look at the components of stress that eventually produce tectonic structures. In later chapters we will use these concepts to examine the relationship between geologic structures and stress.

To understand tectonic processes we must be familiar with the fundamental principles of mechanics. **Mechanics** is concerned with the action of forces on

bodies and their effect; you can say that mechanics is the science of motion. **Newtonian**¹ (or *classical*) **mechanics** studies the action of forces on rigid bodies. The equations of Newtonian mechanics adequately describe a range of *movements* in the natural world, from the entertaining interaction between colliding balls at a game of pool (Figure 3.2a) to the galactic dance of the planets in our solar system. When reaching the subatomic level, Newtonian mechanics starts to break down and we enter the complex realm of quantum mechanics. In tectonic structures we commonly deal with interactions that involve not only movement, but also **distortion**; material displacements occur both between and within bodies. Imagine playing pool with balls made up of jelly rather than solids (Figure 3.2b). The theory associated with this type of behavior is the focus of **continuum mechanics**. In continuum mechan-

¹After Isaac Newton (1642–1727).



FIGURE 3.1 Aerial view of the Karakoram range of the Himalaya.

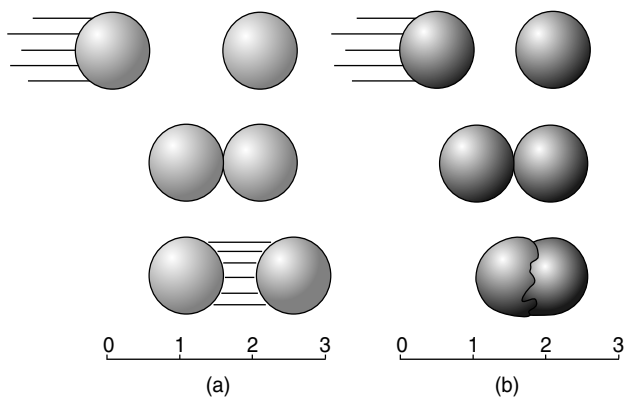

FIGURE 3.2 The interaction of nondeformable bodies is described by Newtonian (or classical) mechanics [a] and that between deformable bodies by continuum mechanics [b]. Imagine the difference between playing pool with regular balls and balls made of jelly.

ics, a material is treated as a continuous medium (hence the name), that is, there are no discontinuities that appreciably affect its behavior. This may seem inappropriate for rocks at first, because we know that they consist of grains whose boundaries are material discontinuities by definition. Yet, on the scale of a rock body containing thousands or more grains we may consider the system statistically homogeneous. Indeed, the predictions from continuum mechanics theory give us adequate first-order descriptions of displacements in many natural

rocks. The primary reason to use the simplifications of continuum mechanics is that it provides us with a mathematical description of deformation in relatively straightforward terms. When the behavior of rocks is dominated by discrete discontinuities, like fractures, continuum mechanics theory no longer holds. Then we need to resort to more complex modeling methods that fall outside the scope of this book.

By the time you have reached the end of this chapter, a good number of terms and concepts will have appeared.

TABLE 3.1	TERMINOLOGY AND SYMBOLS OF FORCE AND STRESS
Force	Mass times acceleration ($F = m \cdot a$; Newton's second law); symbol F
Stress	Force per unit area (F/A); symbol σ
Anisotropic stress	At least one principal stress has a magnitude unequal to the other principal stresses (describes an ellipsoid)
Deviatoric stress	Component of the stress that remains after the mean stress is removed; this component of the stress contains the six shear stresses; symbol σ_{dev}
Differential stress	The difference between two principal stresses (e.g., $\sigma_1 - \sigma_3$), which by definition is ≥ 0 ; symbol σ_d
Homogeneous stress	Stress at each point in a body has the same magnitude and orientation
Hydrostatic stress/pressure	Isotropic component of the stress; strictly, the pressure at the base of a water column
Inhomogeneous stress	Stress at each point in a body has different magnitude and/or orientation
Isotropic stress	All three principal stresses have equal magnitude (describes a sphere)
Lithostatic stress/pressure	Isotropic pressure at depth in the Earth arising from the overlying rock column (density \times gravity \times depth, $\rho \cdot g \cdot h$); symbol P_l
Mean stress	$(\sigma_1 + \sigma_2 + \sigma_3)/3$; symbol σ_{mean}
Normal stress	Stress component oriented perpendicular to a given plane; symbol σ_n
Principal plane	Plane of zero shear stress; three principal planes exist
Principal stress	The normal stress on a plane with zero shear stress; three principal stresses exist, with the convention $\sigma_1 \geq \sigma_2 \geq \sigma_3$
Shear stress	Stress parallel to a given plane; symbol σ_s (sometimes the symbol τ is used)
Stress ellipsoid	Geometric representation of stress; the axes of the stress ellipsoid are the principal stresses
Stress field	The orientation and magnitudes of stresses in a body
Stress tensor	Mathematical description of stress (stress is a second-order tensor)
Stress trajectory	Principal stress directions in a body

For convenience and future reference, therefore, some of the more common terms are described in Table 3.1.

3.2 UNITS AND FUNDAMENTAL QUANTITIES

When measuring something you must select a unit for the quantity that is to be measured. The physical properties of a material can be expressed in terms of four fundamental quantities: *mass*, *length*, *time*, and *charge*. For our purposes we can ignore the quantity charge, which describes the electromagnetic interaction of particles. It plays a role, however, when we try to understand the behavior of materials at the atomic scale. The units of mass, length, and time are the kilogram (kg),

the meter (m), and the second (s), respectively. This notation follows the *Système International* (French), better known as SI units. Throughout the text we will use SI units, but other conventions remain popular in geology (such as “kilobar,” which is a measure of pressure). Where appropriate we will add these units in parentheses. In Table 3.2 the SI units of stress and some common conversions are given.

The symbol for mass is $[m]$, for length $[l]$, and for time $[t]$. Velocity $[v]$, which combines the fundamental quantities of length and time, has the units of length divided by time. In conventional symbols this is written as

$$[v] : [lt^{-1}]$$

in which the colon means “has the quantity of.” Such **dimensional analysis** is a check on the relevance of an equation. We begin by using it in the case of a force.

TABLE 3.2		UNITS OF STRESS AND THEIR CONVERSIONS				
	bar	dynes/cm ²	atmosphere	kg/cm ²	pascal (Pa)	pounds/in ² (psi)
bar		10 ⁶	0.987	1.0197	10 ⁵	14.503
dynes/cm ²	10 ⁻⁶		0.987 × 10 ⁻⁶	1.919 × 10 ⁻⁶	0.1	14.503 × 10 ⁻⁶
atmosphere	1.013	1.013 × 10 ⁶		1.033	1.013 × 10 ⁵	14.695
kg/cm ²	0.981	0.981 × 10 ⁶	0.968		0.981 × 10 ⁵	14.223
pascal (Pa)	10 ⁻⁵	10	0.987 × 10 ⁻⁵	1.0197 × 10 ⁻⁵		14.503 × 10 ⁻⁵
pounds/in ² (psi)	6.895 × 10 ⁻²	6.895 × 10 ⁴	6.81 × 10 ⁻²	7.03 × 10 ⁻²	6.895 × 10 ³	

To use this table start in the left-hand column and read along the row to the column for which a conversion is required. For example, 1 bar = 10⁵ Pa or 1 Pa = 14.5 × 10⁻⁵ psi.

3.3 FORCE

Kicking or throwing a ball shows that a force changes the velocity of an object. Newton's first law of motion, also called the **Law of Inertia**, says that in the absence of a force a body moves either at constant velocity or is at rest. Stated more formally: a free body moves without acceleration. Change in velocity is called acceleration [a], which is defined as velocity divided by time:

$$[a] : [vt^{-1}] : [lt^{-2}]$$

The unit of acceleration, therefore, is m/s².

Force [F], according to Newton's **Second Law of Motion**, is mass multiplied by acceleration:

$$[F] : [ma] : [mlt^{-2}]$$

The unit of force is kg · m/s², called a *newton* (N) in SI units. You can feel the effect of mass when you throw a tennis ball and a basketball and notice that a different force is required to move each of them.

Force, like velocity, is a vector quantity, meaning that it has both magnitude and direction. So it can be graphically represented by a line with an arrow on one side. Manipulation of forces conforms to the rules of vector algebra. For example, a force at an angle to a given plane can be geometrically resolved into two components; say, one parallel and one perpendicular to that plane.

Natural processes can be described with four basic forces: (1) the gravity force, (2) the electromagnetic force, (3) the nuclear or strong force, and (4) the weak force. Gravity is a special force that acts over large dis-

tances and is always attractive; for example, the ocean tides reflect the gravitational interaction between the Moon and the Earth. The other three forces act only over short ranges (atomic scale) and can be attractive or repulsive. The electromagnetic force describes the interaction between charged particles, such as the electrons around the atomic nucleus; the strong force holds the nucleus of an atom together; and the weak force is associated with radioactivity. It is quite possible that only one fundamental force exists in nature, but, despite the first efforts of Albert Einstein² and much progress since then, it has not so far been possible to formulate a **Grand Unified Theory** to encompass all four forces. The force of gravity has proved to be a particular problem.

Forces that result from action of a field at every point within the body are called **body forces**. Bungee jumping gives you a very vivid sensation of body forces though the action of gravity. The magnitude of body forces is proportional to the mass of the body. Forces that act on a specific surface area in a body are called **surface forces**. They reflect the pull or push of the atoms on one side of a surface against the atoms on the other side. Examples are a cuestick's force on a pool ball, the force of expanding gases on an engine piston, and the force of the jaws of a vice. The magnitude of surface forces is proportional to the area of the surface.

Forces that act on a body may change the velocity of (that is, accelerate) the body, and/or may result in a shape change of the body, meaning acceleration of one part of the body with respect to another part. Although force is an important concept, it does not distinguish

²German-born theoretical physicist (1879–1955).

the effect of an equal force on bodies of equal mass but with different shapes. Imagine the effect of the same force applied to a sharp object and a dull object. For example, a human is comfortably supported by a water bed, but when you place a nail between the person and the water bed, the effect is quite dramatic. Using a more geologic experience, consider hitting a rock with a pointed or a flat hammer using the same force. The rock cracks more easily with the pointed hammer than with the flat-headed hammer; in fact, we apply this principle when we use a chisel rather than a sledge hammer to collect rock samples. These examples of the intensity of force lead us into the topic of stress.

3.4 STRESS

Stress, represented by the symbol σ (sigma), is defined as the force per unit area $[A]$, or $\sigma = F/A$. You can, therefore, consider stress as the *intensity of force*, or a measure of how concentrated a force is. A given force acting on a small area (the pointed hammer mentioned previously) will have a greater intensity than that same force acting on a larger area (a flat-headed hammer), because the stress associated with the smaller area is greater than that with the larger area. Those of you remembering turntables and vinyl records (ask your parents) are familiar with this effect. The weight of the arm holding the needle is only a few grams, but the stress of the needle on the vinyl record is orders of magnitude greater because the contact area between needle and record is very small. The high stresses at the area of contact eventually gave rise to scratches and ticks in the records, so it is little wonder that we have embraced digital technologies.

You will see that stress is a complex topic, because its properties depend on the reference system. Stress that acts on a plane is a vector quantity, called **traction**, whereas stress acting on a body is described by a higher order entity, called a **stress tensor**. In the next few pages we will gradually develop the pertinent concepts and components of stress.

Because stress is force per unit area it is expressed in terms of the following fundamental quantities:

$$[\sigma] : [mlt^{-2} \cdot l^{-2}] \text{ or } [ml^{-1} \cdot t^{-2}]$$

The corresponding unit of stress is $\text{kg/m} \cdot \text{s}^2$ (or N/m^2), which is called a pascal (Pa).³ Instead of this SI unit,

³After Blaise Pascal (1623–1662).

however, many geologists continue to use the unit bar, which is approximately 1 atmosphere. These units are related as follows:

$$1 \text{ bar} = 10^5 \text{ Pa} \approx 1 \text{ atmosphere}$$

In geology you will generally encounter their larger equivalents, the kilobar (kbar) and the megapascal (MPa):

$$1 \text{ kbar} = 1000 \text{ bar} = 10^8 \text{ Pa} = 100 \text{ MPa}$$

The unit gigapascal (1 GPa = 1000 MPa = 10 kbar) is used to describe the very high pressures that occur deep in the Earth. For example, the pressure at the core-mantle boundary, located at a depth of approximately 2900 km, is ~135 GPa, and at the center of the Earth (at a depth of 6370 km) the pressure exceeds 350 GPa. Later we will see how these values can be calculated (Section 3.9).

3.5 TWO-DIMENSIONAL STRESS: NORMAL STRESS AND SHEAR STRESS

Stress acting on a plane is a vector quantity, meaning that it has both magnitude and direction; it is sometimes called *traction*. Stress on an arbitrarily oriented plane, however, is not necessarily perpendicular to that plane, but, like a vector, it can be resolved into components normal to the plane and parallel to the plane (Figure 3.3). The vector component normal to the plane is called the **normal stress**, for which we use the symbol σ_n (some-

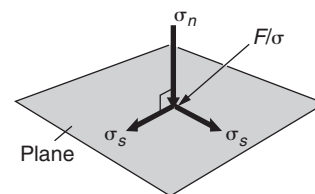

σ_n is normal stress
 σ_s is shear stress
 F is force; σ is stress

FIGURE 3.3 The stress on a two-dimensional plane is defined by a stress acting perpendicular to the plane [the normal stress] and a stress acting along the plane [the shear stress]. The normal stress and shear stress are perpendicular to one another.

FIGURE 3.4 The relationship between force (F) and stress (σ) on a plane. Section through a cube showing face $ABCD$ with ribs of length AB on which a force F is applied. This force is resolved into orientations parallel (F_s) and perpendicular (F_n) to a plane that makes an angle θ with the top and bottom surface (EF is the trace of this plane). The magnitudes of vectors F_s and F_n are a function of the angle θ : $F_n = F \cdot \cos \theta$, $F_s = F \cdot \sin \theta$. The magnitude of the normal (σ_n) and shear stress (σ_s) is a function of the angle θ and the area: $\sigma_n = \sigma \cos^2 \theta$, $\sigma_s = \sigma \frac{1}{2} (\sin 2\theta)$. (a) Force F on plane; (b) stress σ on plane; (c) normalized values of F_n and σ_n on plane with angle θ ; (d) normalized values of F_s and σ_s on a plane with angle θ .

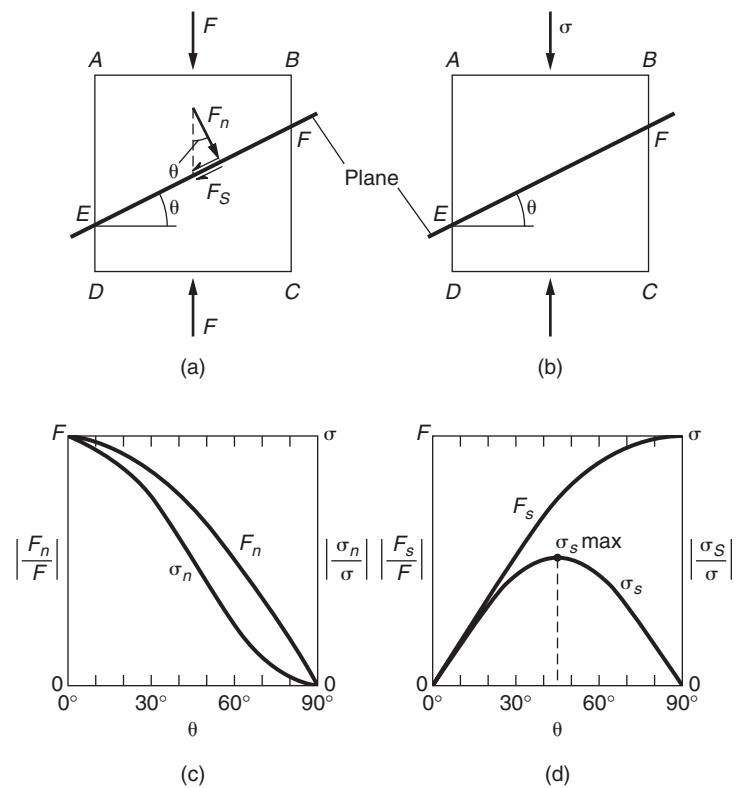

times just the symbol σ is used); the vector component along the plane is the **shear stress** and has the symbol σ_s (sometimes the symbol τ (tau) is used).

In contrast to the resolution of forces, the resolution of stress into its components is not straightforward, because the area changes as a function of the orientation of the plane with respect to the stress vector. Let us first examine the resolution of stress on a plane in some detail, because, as we will see, this has important implications.

In Figure 3.4, stress σ has a magnitude F/AB and makes an angle θ with the top and bottom of our square. The forces perpendicular (F_n) and parallel (F_s) to the plane EF are

$$F_n = F \cos \theta = \sigma AB \cos \theta = \sigma EF \cos^2 \theta \quad \text{Eq. 3.1}$$

$(AB = EF \cos \theta)$

$$F_s = F \sin \theta = \sigma AB \sin \theta = \sigma EF \sin \theta \cos \theta = \sigma EF \frac{1}{2} (\sin 2\theta) \quad \text{Eq. 3.2}$$

Thus the corresponding stresses are

$$\sigma_n = F_n/EF = \sigma \cos^2 \theta \quad \text{Eq. 3.3}$$

$$\sigma_s = F_s/EF = \sigma \frac{1}{2} (\sin 2\theta) \quad \text{Eq. 3.4}$$

You notice that the equation for the normal stress and the normal force are different, as are the equations for F_s and σ_s . We graphically illustrate this difference between forces and stresses on an arbitrary plane by

plotting their normalized values as a function of the angle θ in Figure 3.4c and d, respectively. In particular, the relationship between F_s and σ_s is instructive for gaining an appreciation of the area dependence of stress. Both the shear force and the shear stress initially increase with increasing angle θ ; at 45° the shear stress reaches a maximum and then decreases, while F_s continues to increase.

Thus, the stress vector acting on a plane can be resolved into vector components perpendicular and parallel to that plane, but their magnitudes vary as a function of the orientation of the plane. Let us further examine the properties of stress by determining the stress state for a three-dimensional body.

3.6 THREE-DIMENSIONAL STRESS: PRINCIPAL PLANES AND PRINCIPAL STRESSES

Previously, we discussed stress acting on a single plane (the two-dimensional case), recognizing two vector components, the normal stress and the shear stress (Figure 3.3). However, to describe stress on a randomly oriented plane in space we need to consider the three-dimensional case. We limit unnecessary complications

by setting the condition that the body containing the plane is at rest. So a force applied to the body is balanced by an opposing force of equal magnitude but opposite sign; this condition is known as Newton's **Third Law of Motion**. Using another Newtonian sports analogy, kick a ball that rests against a wall and notice how the ball (the wall, in fact) pushes back with equal enthusiasm.

3.6.1 Stress at a Point

We shrink our three-dimensional body containing the plane of interest down to the size of a point for our analysis of the stress state of an object. Why this seemingly obscure transformation? Recall that two nonparallel planes have a line in common and that three or more nonparallel planes have a point in common. In other words, a point defines the intersection of an infinite number of planes with different orientations. The stress state at a point, therefore, can describe the stresses acting on all planes in a body.

In Figure 3.5a the normal stresses (σ) acting on four planes (a – d) that intersect in a single point are drawn. For clarity, we limit our illustrations to planes that are all perpendicular to the surface of the page, allowing the use of slice through the body. You will see later that this geometry easily expands into the full three-dimensional case. Because of Newton's Third Law of Motion, the stress on each plane must be balanced by one of opposite sign ($\sigma = -\sigma$). Because stress varies as a function of orientation, the magnitude of the normal stress on each plane (represented by the vector length) is different. If we draw an envelope around the end points of these stress vectors (heavy line in Figure 3.5a), we obtain an ellipse. Recall from geometry that an ellipse is defined by at least three nonperpendicular axes, which are shown in Figure 3.5a. This means that the magnitude of the stress for all possible planes is represented by a point on this **stress ellipse**. Now, the same can be done in three dimensions, but this is hard to illustrate on a piece of flat paper. Doing the same analysis in three dimensions, we obtain an envelope that is the three-dimensional equivalent of an ellipse, called an ellipsoid (Figure 3.5b). This **stress ellipsoid** fully describes the stress state at a point and enables us to determine the stress for any given plane. Like all ellipsoids, the stress ellipsoid is defined by three mutually perpendicular axes, which are called the **principal stresses**. These principal stresses have two properties: (1) they are orthogonal to each other, and (2) they are perpendicular to three planes that do not contain shear stresses; these planes are called the **prin-**

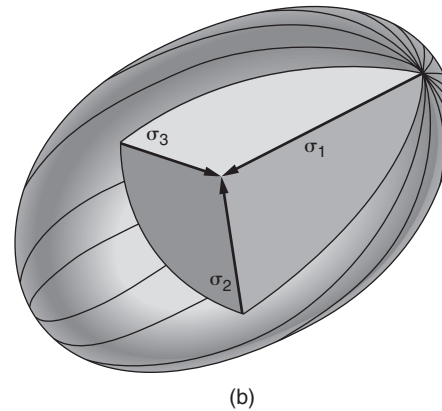
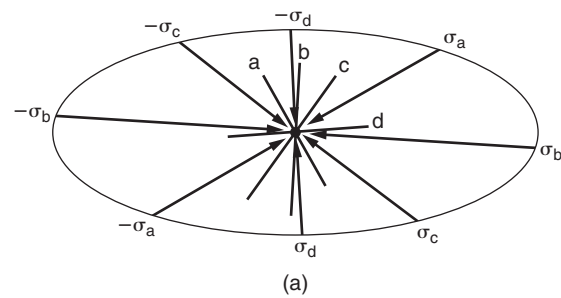

FIGURE 3.5 [a] A point represents the intersection of an infinite number of planes, and the stresses on these planes describe an ellipse in the two-dimensional case. In three dimensions this stress envelope is an ellipsoid [b], defined by three mutually perpendicular principal stress axes [$\sigma_1 \geq \sigma_2 \geq \sigma_3$]. These three axes are normal to the principal planes of stress.

cipal planes of stress. So, we can describe the stress state of a body simply by specifying the orientation and magnitude of three principal stresses.

3.6.2 The Components of Stress

The orientation and magnitude of the stress state of a body is defined in terms of its components projected in a Cartesian reference frame, which contains three mutually perpendicular coordinate axes, x , y , and z . To see this, instead of a point representing an infinite number of planes on which our stress acts, we draw our point as an infinitely small cube whose ribs are perpendicular to each of the coordinate axes, x , y , and z . We resolve the stress acting on each face of a cube into three components (Figure 3.6). For a face normal to the x -axis the components are σ_{xx} , which is the component *normal* to that face, and σ_{xy} and σ_{xz} , which are the two components *parallel* to that face. These last two stresses are shear stress components, acting along one of the other coordinate axes y and z , respectively.

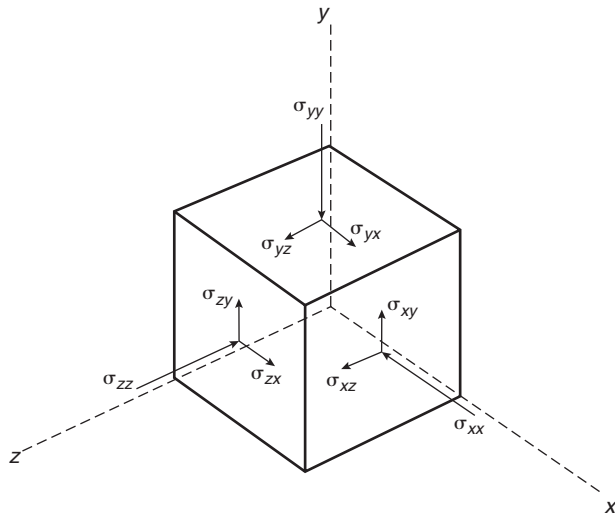

FIGURE 3.6 Resolution of stress into components perpendicular [three normal stresses, σ_n] and components parallel [six shear stresses, σ_s] to the three faces of an infinitesimally small cube, relative to the reference system x , y , and z .

Applying this same procedure for the faces normal to y and z , we obtain a total of nine stress components (Figure 3.6):

	In the direction of		
	x :	y :	z :
stress on the face normal to x :	σ_{xx}	σ_{xy}	σ_{xz}
stress on the face normal to y :	σ_{yx}	σ_{yy}	σ_{yz}
stress on the face normal to z :	σ_{zx}	σ_{zy}	σ_{zz}

The columns, from left to right, represent the components in the x , y , and z directions of the coordinate system, respectively. σ_{xx} , σ_{yy} , and σ_{zz} are normal stress components and the other six are shear stress components. Because we specified that the body itself is at rest, three of the six shear stress components must be equivalent (σ_{xy} and σ_{yx} , σ_{yz} and σ_{zy} , and σ_{xz} and σ_{zx}). If these components were unequal, the body would move, which violates our at-rest condition. So, rather than nine components, we are left with *six independent stress components* to describe the stress acting on any arbitrary infinitesimal body:

	In the direction of		
	x :	y :	z :
stress on the face normal to x :	σ_{xx}	σ_{xy}	σ_{xz}
stress on the face normal to y :	σ_{xy}	σ_{yy}	σ_{yz}
stress on the face normal to z :	σ_{xz}	σ_{yz}	σ_{zz}

The only ingredient left in our description is a *sign convention*. In physics and engineering, tensile stress

is considered positive, and compressive stress negative. In geology, however, it is customary to make compression positive and tension negative, because compression is more common in the Earth. We will, therefore, use the geologic sign convention throughout the text; however, don't confuse this with the engineering sign convention used in some other textbooks.⁴

For any given state of stress there is at least one set of three mutually perpendicular planes on which the shear stresses are zero. In other words, you can rotate our infinitesimal cube such that the shear stresses on each of its three faces are zero. In this orientation, these three faces are the **principal planes of stress** (the same ones that we described in our stress ellipsoid; Section 3.6.1) and they intersect in three mutually perpendicular axes that are the **principal axes of stress** (which are the same as the axes of the stress ellipsoid in Section 3.6.1). The stresses acting along them are called the **principal stresses** for a given point or homogeneous domain within a body.

3.6.3 Stress States

If the three principal stresses are equal in magnitude, we call the stress **isotropic**. This stress state is represented by a sphere rather than an ellipsoid, because all three radii are equal. If the principal stresses are unequal in magnitude, the stress is called **anisotropic**. By convention, the maximum principal stress is given the symbol σ_1 , the intermediate and minimum principal stresses acting along the other two axes are given the symbols σ_2 and σ_3 , respectively. Thus, by (geologic) convention:

$$\sigma_1 \geq \sigma_2 \geq \sigma_3$$

By changing the relative values of the three principal stresses we define several common **stress states**:

General triaxial stress:	$\sigma_1 > \sigma_2 > \sigma_3 \neq 0$
Biaxial (plane) stress:	one axis = 0 (e.g., $\sigma_1 > 0 > \sigma_3$)
Uniaxial compression:	$\sigma_1 > 0$; $\sigma_2 = \sigma_3 = 0$
Uniaxial tension:	$\sigma_1 = \sigma_2 = 0$; $\sigma_3 < 0$
Hydrostatic stress (pressure):	$\sigma_1 = \sigma_2 = \sigma_3$

So, we learned that the stress state of a body is defined by nine components. Mathematically this

⁴A further source of possible confusion is that elastic constants of materials are given with the engineering convention, so their sign needs to be reversed in our use.

ellipsoid is described by a 3×3 matrix (called a **second-rank tensor**). Although it may seem easier at first to use a geometric representation of stress, as we just did, for the analysis of stress in bodies it is better to apply mathematical operations. We will return to this later in the chapter (Section 3.10).

3.7 DERIVING SOME STRESS RELATIONSHIPS

Now that we can express the stress state of a body by its principal stresses, we can derive several useful relationships. Let's carry out a simple classroom experiment in which we compress a block of clay between two planks (Figure 3.7). As the block of clay develops a fracture, we want to determine what the normal and the shear stresses on the fracture plane are. To answer this question our approach is similar to our previous one (Equations 3.1 to 3.4), but now we express the normal and shear stresses in terms of the principal stress axes.

The principal stresses acting on our block of clay are σ_1 (maximum stress), σ_2 (intermediate stress), and σ_3 (minimum stress). Since we carry out our experiment under atmospheric conditions, the values of σ_2 and σ_3 will be equal, and we may simplify our analysis by neglecting σ_2 and considering only the σ_1 - σ_3 plane, as shown in Figure 3.7. The fracture plane makes an angle θ (theta) with σ_3 . This plane makes the trace AB in Figure 3.7b, which we assign unit length (that is, 1) for convenience. We can resolve AB along AC (parallel to σ_1) and along BC (parallel to σ_3). Then, by trigonometry, we see that the area represented by $AC = \sin \theta$, and the area represented by $BC = \cos \theta$. Note that if we assign dimension L to AB then $AC = L \cdot \sin \theta$ and $BC = L \cdot \cos \theta$.

Next we consider the forces acting on each of the surface elements represented by AB , BC , and AC . Since force equals stress times the area over which it acts, we obtain

$$\begin{aligned} \text{force on side } BC &= \sigma_1 \cdot \cos \theta \\ \text{force on side } AC &= \sigma_3 \cdot \sin \theta \end{aligned}$$

The force on side AB consists of a normal force (i.e., $\sigma_n \cdot 1$) and a shear force (i.e., $\sigma_s \cdot 1$); recall that force is stress times area.

For equilibrium, the forces acting in the direction of AB must balance, and so must the forces acting per-

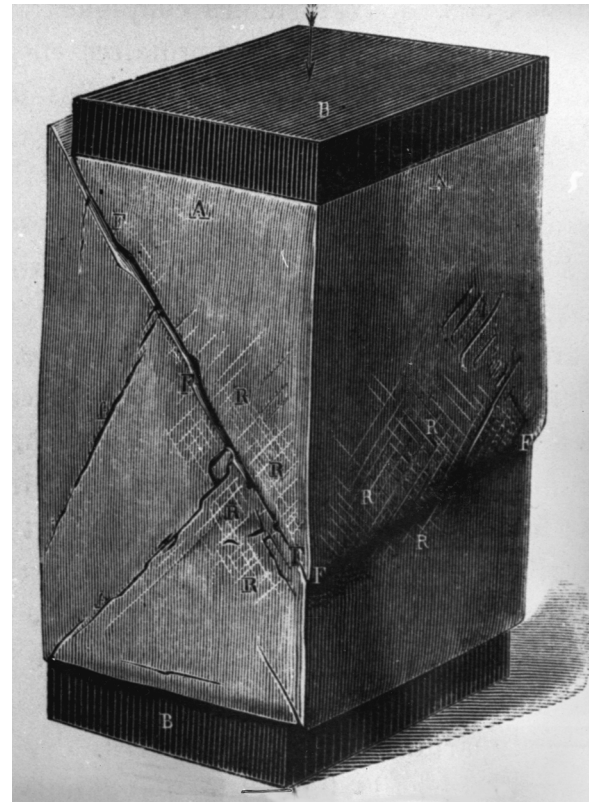

(a)

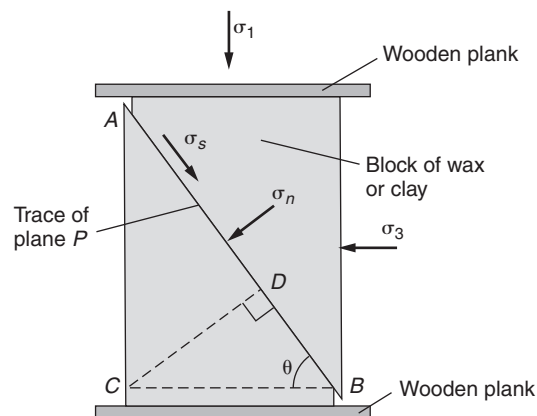

(b)

FIGURE 3.7 Determining the normal and shear stresses on a plane in a stressed body as a function of the principal stresses. (a) An illustration from the late nineteenth-century fracture experiments of Daubrée using wax. (b) For a classroom experiment, a block of clay is squeezed between two planks of wood. AB is the trace of fracture plane P in our body that makes an angle θ with σ_3 . The two-dimensional case shown is sufficient to describe the experiment, because σ_2 equals σ_3 [atmospheric pressure].

pendicular to AB (which is parallel to CD). Hence, resolving along CD :

$$\begin{aligned} \text{force } \perp AB &= \text{force } \perp BC \text{ resolved on } CD + \\ \text{force } \perp AC &\text{ resolved on } CD \end{aligned}$$

or

$$1 \cdot \sigma_n = \sigma_1 \cos \theta \cdot \cos \theta + \sigma_3 \sin \theta \cdot \sin \theta \quad \text{Eq. 3.5}$$

$$\sigma_n = \sigma_1 \cos^2 \theta + \sigma_3 \sin^2 \theta \quad \text{Eq. 3.6}$$

Substituting these trigonometric relationships in Equation 3.6, we obtain

$$\cos^2 \theta = \frac{1}{2}(1 + \cos 2\theta)$$

$$\sin^2 \theta = \frac{1}{2}(1 - \cos 2\theta)$$

Simplifying, gives

$$\sigma_n = \frac{1}{2}(\sigma_1 + \sigma_3) + \frac{1}{2}(\sigma_1 - \sigma_3) \cos 2\theta \quad \text{Eq. 3.7}$$

and,

$$\begin{aligned} \text{force parallel } AB &= \text{force } \perp BC \text{ resolved on } AB + \\ \text{force } \perp AC &\text{ resolved on } AB \end{aligned}$$

or

$$1 \cdot \sigma_s = \sigma_1 \cos \theta \cdot \sin \theta - \sigma_3 \sin \theta \cdot \cos \theta \quad \text{Eq. 3.8}$$

Note that the force perpendicular to AC resolved on AB acts in a direction opposite to the force perpendicular to BC resolved on AB , hence a negative sign is needed in Eq. 3.8, which further simplifies to

$$\sigma_s = (\sigma_1 - \sigma_3) \sin \theta \cdot \cos \theta \quad \text{Eq. 3.9}$$

Substituting this trigonometric relationship in Eq. 3.9, we get

$$\sin \theta \cdot \cos \theta = \frac{1}{2} \sin 2\theta$$

which gives

$$\sigma_s = \frac{1}{2}(\sigma_1 - \sigma_3) \sin 2\theta \quad \text{Eq. 3.10}$$

From Equations 3.7 and 3.10 we can determine that the planes of maximum normal stress are at an angle θ of 0° with σ_3 , because $\cos 2\theta$ reaches its maximum value ($\cos 0^\circ = 1$). Secondly, planes of maximum shear stress lie at an angle θ of 45° with σ_3 because $\sin 2\theta$ reaches its maximum value ($\sin 90^\circ = 1$) (see also Figure 3.2c and d). Whereas faulting resulted in a shearing motion along the fault plane, we find that the fault plane in our experiment is not parallel to the plane of maximum shear stress ($\theta > 45^\circ$). This perhaps surprising result

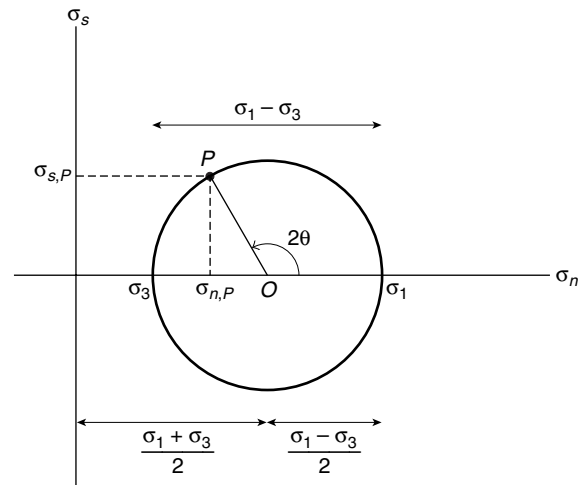

FIGURE 3.8 The Mohr diagram for stress. Point P represents the plane in our clay experiment of Figure 3.7.

reflects a fundamental property of solids that we analyze in Chapter 6.

3.8 MOHR DIAGRAM FOR STRESS

The equations we derived for σ_n and σ_s do not offer an obvious sense of their values as a function of orientation of a plane in our block of clay. Of course, a programmable calculator or simple computer program will do the job, but a convenient graphical method, known as the **Mohr diagram**⁵ (Figure 3.8), was introduced over a century ago to solve Equations 3.7 and 3.10. A Mohr diagram is an “XY”-type (Cartesian) plot of σ_s versus σ_n that graphically solves the equations for normal stress and shear stress acting on a plane within a stressed body. In our experiences, many people find the Mohr construction difficult to comprehend. So we’ll first examine the proof and underlying principles of this approach to try to take the magic out of the method.

If we rearrange Equations 3.7 and 3.10 and square them, we get

$$[\sigma_n - \frac{1}{2}(\sigma_1 + \sigma_3)]^2 = [\frac{1}{2}(\sigma_1 - \sigma_3)]^2 \cos^2 2\theta \quad \text{Eq. 3.11}$$

$$\sigma_s^2 = [\frac{1}{2}(\sigma_1 - \sigma_3)]^2 \sin^2 \theta \quad \text{Eq. 3.12}$$

⁵Named after Otto Mohr (1835–1918).

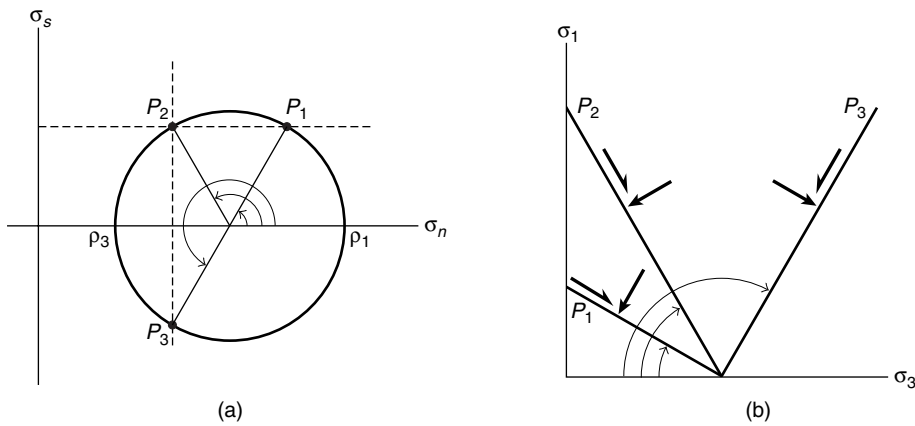

FIGURE 3.9 For each value of the shear stress and the normal stress there are two corresponding planes, as shown in the Mohr diagram [a]. The corresponding planes in $\sigma_1 - \sigma_3$ space are shown in [b].

Adding Equations 3.11 and 3.12 gives

$$\begin{aligned} [\sigma_n - \frac{1}{2}(\sigma_1 + \sigma_3)]^2 + \sigma_s^2 = \\ [\frac{1}{2}(\sigma_1 - \sigma_3)]^2 \cdot (\cos^2 2\theta + \sin^2 2\theta) \end{aligned} \quad \text{Eq. 3.13}$$

Using the trigonometric relationship

$$(\cos^2 2\theta + \sin^2 2\theta) = 1$$

in Equation 3.13 gives

$$[\sigma_n - \frac{1}{2}(\sigma_1 + \sigma_3)]^2 + \sigma_s^2 = [\frac{1}{2}(\sigma_1 - \sigma_3)]^2 \quad \text{Eq. 3.14}$$

Note that Equation 3.14 has the form $(x - a)^2 + y^2 = r^2$, which is the general equation for a circle with radius r and centered on the x -axis at distance a from the origin. Thus the Mohr circle has a radius $\frac{1}{2}(\sigma_1 - \sigma_3)$ that is centered on the σ_n axis at a distance $\frac{1}{2}(\sigma_1 + \sigma_3)$ from the origin. The construction is shown in Figure 3.8. You also see from this figure that the Mohr circle's radius, $\frac{1}{2}(\sigma_1 - \sigma_3)$, is the maximum shear stress, $\sigma_{s, \max}$. The stress difference $(\sigma_1 - \sigma_3)$, called the **differential stress**, is indicated by the symbol σ_d .

3.8.1 Constructing the Mohr Diagram

To construct a Mohr diagram we draw two mutually perpendicular axes; σ_n is the abscissa (x -axis) and σ_s is the ordinate (y -axis). In our clay deformation experiment, the maximum principal stress (σ_1) and the minimum principal stress (σ_3) act on plane P that makes an angle θ with the σ_3 direction (Figure 3.7); in the Mohr construction we then plot σ_1 and σ_3 on the σ_n -axis

(Figure 3.8). These principal stress values are plotted on the σ_n axes because they are normal stresses, but with the special condition that the planes on which they act, the principal planes, have zero shear stress ($\sigma_s = 0$). We then construct a circle through points σ_1 and σ_3 , with O , the midpoint, at $\frac{1}{2}(\sigma_1 + \sigma_3)$ as center, and a radius of $\frac{1}{2}(\sigma_1 - \sigma_3)$. Next, we draw a line OP such that angle $PO\sigma_1$ is equal to 2θ . This step often gives rise to confusion and errors. First, remember that we plot *twice* the angle θ , which is

the angle between the plane and σ_3 , because of the equations we are solving. Second, remember that we measure 2θ from the σ_1 -side on the σ_n -axis.⁶ When this is done, the Mohr diagram is complete and we can read off the value of $\sigma_{n,P}$ along the σ_n -axis, and the value of $\sigma_{s,P}$ along the σ_s -axis for our plane P , as shown in Figure 3.8. We see that

$$\sigma_{n,P} = \frac{1}{2}(\sigma_1 + \sigma_3) + \frac{1}{2}(\sigma_1 - \sigma_3) \cos 2\theta$$

and

$$\sigma_{s,P} = \frac{1}{2}(\sigma_1 - \sigma_3) \sin 2\theta$$

A couple of additional observations can be made from the Mohr diagram (Figure 3.9). There are two planes, oriented at angle θ and its complement ($90 - \theta$), with equal shear stresses but different normal stresses. Also, there are two planes with equal normal stress, but with shear stresses of opposite sign (that is, they act in different directions on these planes).

In general, for each orientation of a plane, defined by its angle θ , there is a corresponding point on the circle. The coordinates of that point represent the normal and shear stresses that act on that plane. For example, when $\theta = 0^\circ$ (that is, for a plane parallel to σ_3), P coincides with σ_1 , which gives $\sigma_n = \sigma_1$ and $\sigma_s = 0$. In other words, for any value of σ_1 and σ_3 ($\sigma_3 = \sigma_2$ in our compression experiment), we can determine σ_n and σ_s graphically for planes that lie at an angle θ with σ_3 . If we decide to change our earlier experi-

⁶Alternative conventions for this construction are also in use, but be careful that they are not mixed.

ment by gluing the planks to the clay block and then moving the planks apart (a tension experiment), we must use a negative sign for the least principal stress (in this case, $\sigma_1 = \sigma_2$ and σ_3 is negative). So the center O of the Mohr circle can lie on either side of the origin, but is always on the σ -axis.

The Mohr diagram also nicely illustrates the attitude of planes along which the shear stress is greatest for a given state of stress. The point on the circle for which σ_s is maximum corresponds to a value of $2\theta = 90^\circ$. For the same point, the magnitude of σ_s is equal to the radius of the circle, that is, $\frac{1}{2}(\sigma_1 - \sigma_3)$. Thus the $(\sigma_1 - \sigma_3)$, the differential stress, is twice the magnitude of the maximum shear stress:

$$\sigma_d = 2\sigma_{s, \max} \quad \text{Eq. 3.15}$$

When there are changes in the principal stress magnitudes without a change in the differential stress, the Mohr circle moves along the σ_n -axis without changing the magnitude of σ_s . In our experiment, this would be achieved by increasing the air pressure in the classroom or carrying out the experiment under water;⁷ this “surrounding” pressure is called the **confining pressure** (P_c) of the experiment. In Chapter 6 we return to the Mohr stress diagram and the role of the confining pressure for fracturing of rocks, but let’s get comfortable with the construction with a simple assignment. Figure 3.10a shows six planes in a stressed body at different angles with σ_3 . Using the graph in Figure 3.10b, draw the Mohr circle and estimate the normal and shear stresses for these six planes. You can check your estimates by using Equations 3.7 and 3.10.

⁷Both conditions can prove uncomfortable.

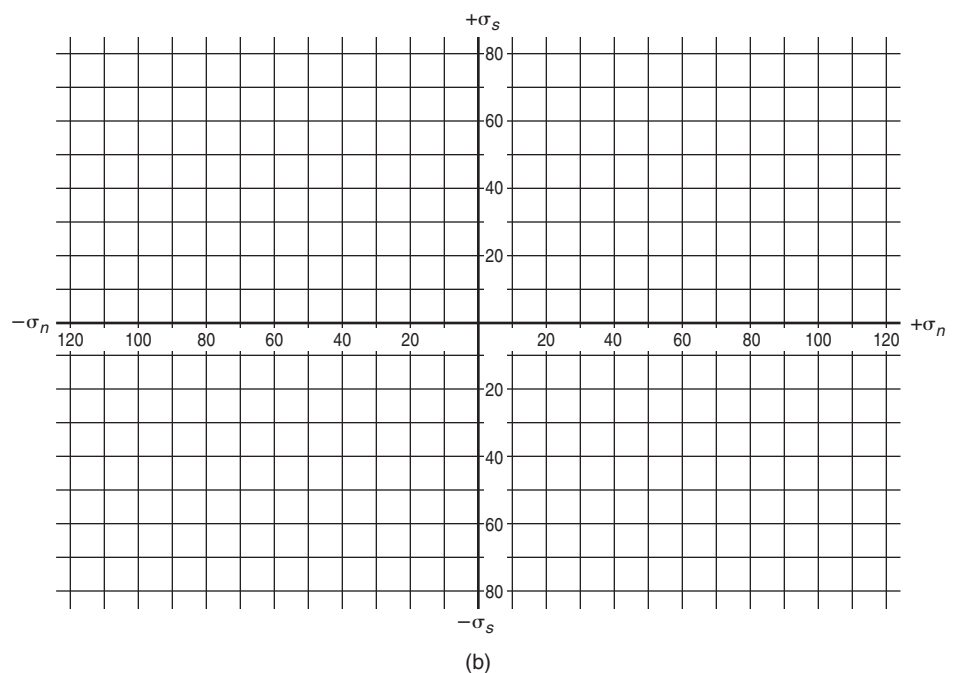
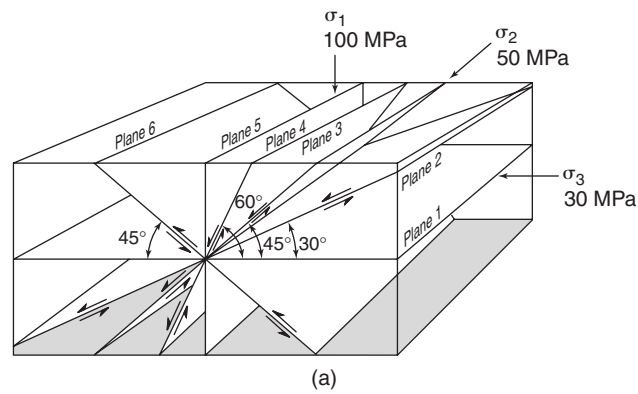

FIGURE 3.10 Adventures with the Mohr circle. To estimate the normal and shear stresses on the the six planes in [a] apply the Mohr construction in [b]. The principal stresses and angles θ are given in [a]. You can check your estimates from the construction in $\sigma_n - \sigma_s$ space by using Equations 3.7 and 3.10.

3.8.2 Some Common Stress States

Now that you are familiar with the Mohr construction, let’s look at its representation of the various stress states that were mentioned earlier. The three-dimensional Mohr diagrams in Figure 3.11 may at first appear a lot more complex than those in our earlier examples, because they represent three-dimensional stress states rather than two-dimensional conditions. Three-dimensional Mohr constructions simply combine three two-dimensional Mohr circles for $(\sigma_1 - \sigma_2)$, $(\sigma_1 - \sigma_3)$, and $(\sigma_2 - \sigma_3)$, and each of these three Mohr circles adheres to the procedures outlined earlier.

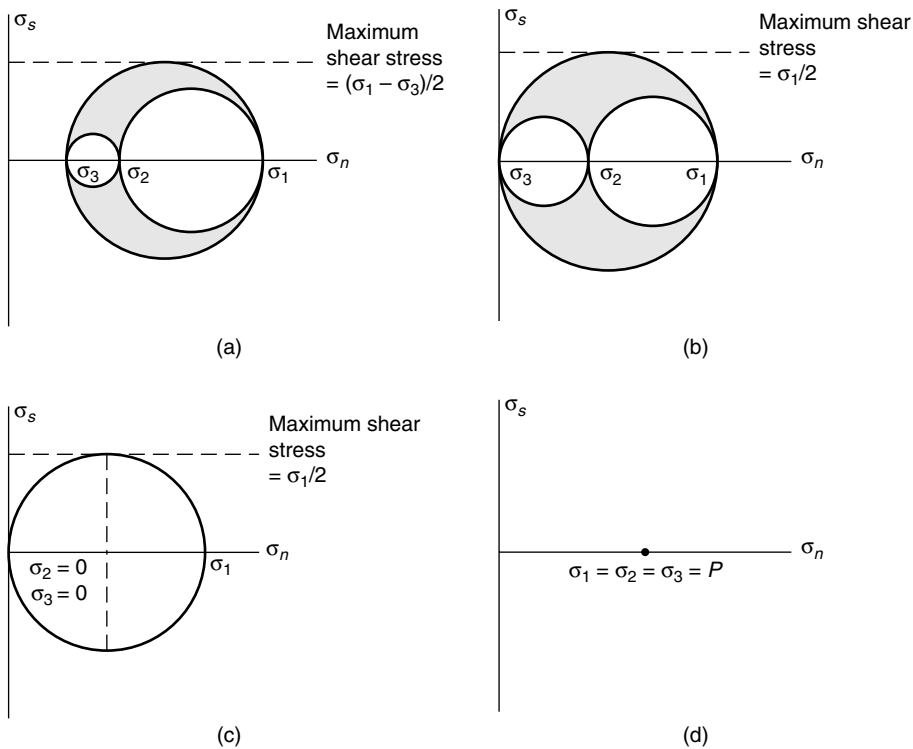

FIGURE 3.11 Mohr diagrams of some representative stress states: [a] triaxial stress, [b] biaxial (plane) stress, [c] uniaxial compression, and [d] isotropic stress or hydrostatic pressure, P [compression is shown].

Figure 3.11a shows the case for general triaxial stress, in which all three principal stresses have nonzero values ($\sigma_1 > \sigma_2 > \sigma_3 \neq 0$). Biaxial (plane) stress, in which one of the principal stresses is zero (e.g., $\sigma_3 = 0$) is shown in Figure 3.11b. Uniaxial compression ($\sigma_2 = \sigma_3 = 0$; $\sigma_1 > 0$) is shown in Figure 3.11c, whereas uniaxial tension ($\sigma_1 = \sigma_2 = 0$; $\sigma_3 < 0$) would place the Mohr circle on the other side of the σ_n -axis. Finally, isotropic stress, often called hydrostatic pressure, is represented by a single point on the σ_n -axis of the Mohr diagram (positive for compression, negative for tension), because all three principal stresses are equal in magnitude ($\sigma_1 = \sigma_2 = \sigma_3$; Figure 3.11d).

3.9 MEAN STRESS AND DEVIATORIC STRESS

In Chapters 4 and 5 we will explore how stresses result in deformation and how stress and strain are related. Because of a body's response to stress, we subdivide the stress into two components, the mean stress and the deviatoric stress (Figure 3.12). The **mean stress** is defined as $(\sigma_1 + \sigma_2 + \sigma_3)/3$, using the symbol σ_m . The

difference between mean stress and total stress is the **deviatoric stress** (σ_{dev}), so

$$\sigma = \sigma_{mean} + \sigma_{dev}$$

The mean stress is often called the hydrostatic component of stress or the **hydrostatic pressure**, because a fluid is stressed equally in all directions. Because the magnitude of the hydrostatic stress is equal in all directions it is an isotropic stress component. When we consider rocks at depth in the Earth we generally refer to **lithostatic pressure**,⁸ P_l , rather than the hydrostatic pressure. The lithostatic stress component is best explained by a simple but powerful calculation. Consider a rock at a depth of 3 km in the middle of a continent. The lithostatic pressure at this point is a function of the weight of the overlying rock column

because other (tectonic) stresses are unimportant. The local pressure is a function of rock density, depth, and gravity:

$$P_l = \rho \cdot g \cdot h \quad \text{Eq. 3.16}$$

If ρ (density) equals a representative crustal value of 2700 kg/m^3 , g (gravity) is 9.8 m/s^2 , and h (depth) is 3000 m , we get

$$P_l = 2700 \cdot 9.8 \cdot 3000 = 79.4 \cdot 10^6 \text{ Pa} \approx 80 \text{ MPa} \quad (\text{or } 800 \text{ bars})$$

In other words, for every kilometer in the Earth's crust the lithostatic pressure increases by approximately 27 MPa. With depth the density of rocks increases, so you cannot continue to use the value of 2700 kg/m^3 . For crustal depths greater than approximately 15 km the average density of the crust is 2900 kg/m^3 . Deeper into Earth the density increases further, reaching as much as $13,000 \text{ kg/m}^3$ in the solid inner core.

⁸Also called overburden pressure.

Because the lithostatic pressure is of equal magnitude in all directions, it follows that $\sigma_1 = \sigma_2 = \sigma_3$. The actual state of stress on a body at depth in the Earth is often more complex than only that from the overlying rock column. Anisotropic stresses that arise from tectonic processes, such as the collision of continental plates or the drag of the plate on the underlying material, contribute to the stress state at depth. The differential stresses of these anisotropic stress components,

however, are many orders of magnitude less than the lithostatic stress. In the crust, differential stresses may reach a few hundred megapascals, but in the mantle, where lithostatic pressure is high, they are only on the order of tens of megapascals or less (see Section 3.13). Yet, such low differential stresses are responsible for the slow motion of “solid” mantle that is a critical element of our planet’s plate dynamics.

Let’s return to Figure 3.12 and the preceding comments. Why divide a body’s stress state into an isotropic (lithostatic/hydrostatic) and an anisotropic (deviatoric) component? For our explanation we return to look at the deformation of a stressed body. Because isotropic stress acts equally in all directions, it results in a *volume change* of the body (Figure 3.12a). Isotropic stress is responsible for the consequences of increasing water pressure at depth on a human body or air pressure changes during take-off and landing of a plane (remember those painfully popping ears?). Place an air-filled balloon under water and you will see that isotropic stress maintains the spherical shape of the balloon, but reduces the volume. Deviatoric stress, on the other hand, changes the *shape* of a body (Figure 3.12b). As we will see in Chapter 4, distortion of a body can often be measured in structural geology, but volume change is considerably more difficult to determine. As in determining distortions, knowledge about the original volume of a body is the obvious way to determine any volume change. Reliable volume markers, however, are rare in rocks and we resort to indirect approaches such as chemical contrasts between deformed and undeformed samples. The division between the isotropic and anisotropic components of stress provides the connection between the volumetric and distortional components of deformation, respectively.

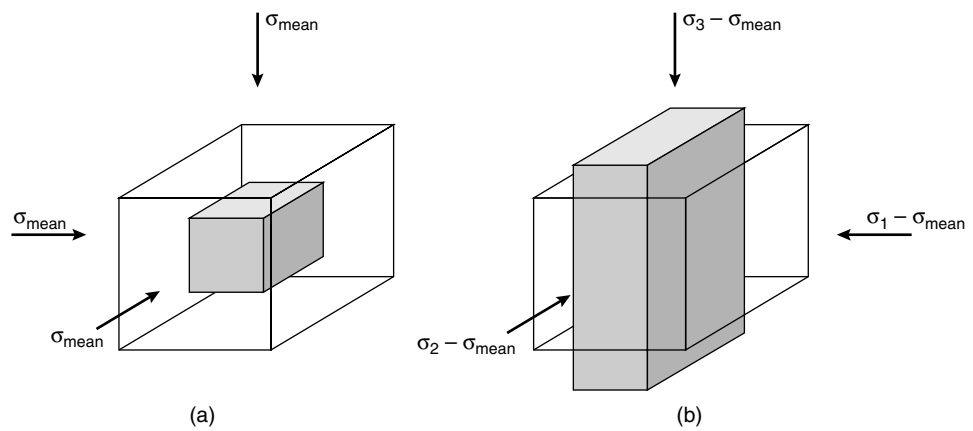

FIGURE 3.12 The mean [hydrostatic] and deviatoric components of the stress. [a] Mean stress causes volume change and [b] deviatoric stress causes shape change.

3.10 THE STRESS TENSOR

The stress ellipsoid is a convenient way to visualize the state of stress, but it is cumbersome for calculations. For example, it is difficult to determine the stresses acting on a randomly chosen plane in a three-dimensional body, or the corresponding stresses when we change the reference system (e.g., by a rotation). In contrast, the **stress tensor**, which mathematically describes the stress state in terms of three orthogonal stress axes, makes such determinations relatively easy. So let us take a look at the stress tensor in a little more detail.

A vector is a physical quantity that has magnitude and direction; it is visualized as an arrow with length and orientation at a point in space. A vector is represented by three coordinates in a Cartesian reference frame that we describe by a matrix consisting of three components. Figure 3.4 showed that stress at a point is a physical quantity that is defined by nine components, which is called a *second-rank tensor*. This is represented by an ellipsoid with orientation, size, and shape at a point in space. The rank of a tensor reflects the number of matrix components and is determined by raising the number 3 to the power of a tensor’s rank; for the stress tensor this means, $3^2 = 9$ components. It follows that a vector is a first-rank tensor ($3^1 = 3$ components) and a scalar is a zero-rank tensor ($3^0 = 1$ component). Geologic examples of zero-rank tensors are pressure, temperature, and time; whereas force, velocity, and acceleration are examples of first-rank tensors.

Consider the transformation of a point P in three-dimensional space defined by coordinates $P(x, y, z)$ to point $P'(x', y', z')$. The transformed condition is identified by adding the prime symbol ($'$). We can describe

the transformation of the three coordinates of P as a function of P' by

$$\begin{cases} x' = ax + by + cz \\ y' = dx + ey + fz \\ z' = gx + hy + iz \end{cases}$$

The tensor that describes the transformation from P to P' is the matrix

$$\begin{bmatrix} a & b & c \\ d & e & f \\ g & h & i \end{bmatrix}$$

In matrix notation, the nine components of a stress tensor are

$$\begin{bmatrix} \sigma_{11} & \sigma_{12} & \sigma_{13} \\ \sigma_{21} & \sigma_{22} & \sigma_{23} \\ \sigma_{31} & \sigma_{32} & \sigma_{33} \end{bmatrix} = [\sigma_{ij}]$$

with σ_{11} oriented parallel to the 1-axis and acting on a plane perpendicular to the 1-axis, σ_{12} oriented parallel to the 1-axis and acting on a plane perpendicular to the 2-axis, and so on. The systematics of these nine components make for an unnecessarily long notation, so in shorthand we write

$$[\sigma_{ij}]$$

where i refers to the row (component parallel to the i -axis) and j refers to the column (component acting on the plane perpendicular to the j -axis).

You will notice the similarity between our approach to the stress tensor and our earlier approach to the description of stress at a point, consisting of one normal stress ($i = j$) and two shear stresses ($i \neq j$) for each of three orthogonal planes. The stress tensor is simply the mathematical representation of this condition. Now we use this notation for decomposing the total stress into the *mean stress* and *deviatoric stress*

$$[\sigma_{ij}] = \begin{bmatrix} \sigma_m & 0 & 0 \\ 0 & \sigma_m & 0 \\ 0 & 0 & \sigma_m \end{bmatrix} + \begin{bmatrix} \sigma_{11} - \sigma_m & \sigma_{12} & \sigma_{13} \\ \sigma_{21} & \sigma_{22} - \sigma_m & \sigma_{23} \\ \sigma_{31} & \sigma_{32} & \sigma_{33} - \sigma_m \end{bmatrix}$$

where $\sigma_m = (\sigma_{11} + \sigma_{22} + \sigma_{33})/3$

Decomposing the stress state in this manner demonstrates the property that shear stresses ($i \neq j$) are restricted to the deviatoric component of the stress, whereas the mean stress contains only normal stresses. Because $\sigma_{ij} = \sigma_{ji}$, both the mean stress and the deviatoric stress are **symmetric tensors**.

Once you have determined the stress tensor, it is relatively easy to change the reference system. In this context, you are reminded that the values of the nine stress components are a function of the reference frame. Thus, when changing the reference frame, say by a rotation, the components of the stress tensor are changed. These transformations are greatly simplified by using mathematics for stress analysis, but we'd need another few pages explaining vectors and matrix transformations before we could show some examples. If you would like to see a more in-depth treatment of this topic, several useful references are given in the reading list.

3.11 A BRIEF SUMMARY OF STRESS

Let's summarize where we are in our understanding of stress. You have seen that there are two ways to talk about stress. First, you can refer to stress on a plane (or *traction*), which can be represented by a vector (a quantity with magnitude and direction) that can be subdivided into a component normal to the plane (σ_n , the *normal stress*) and a component parallel to the plane (σ_s , the *shear stress*). If the shear stress is zero, then the stress vector is perpendicular to the plane, but this is a special case; in general, the stress vector is not perpendicular to the plane on which it acts. It is therefore meaningless to talk about stress without specifying the plane on which it is acting. For example, it is wrong to say "the stress at 1 km depth in the Earth is $00^\circ/070^\circ$," but it is reasonable to say "the stress vector acting on a vertical, north-south striking joint surface is oriented $00^\circ/070^\circ$." In this example there must be a shear stress acting on the fracture; check this for yourself. If the magnitude of this shear stress exceeds the frictional resistance to sliding along the fracture, then there might be movement.

The stress state at a point cannot be described by a single vector. Why? Because a point represents the intersection of an infinite number of planes, and without knowing which plane you are talking about, you cannot define the stress vector. If you want to describe the stress state at a point you must have a tool that will allow you to calculate the stress vector associated with any of the infinite number of planes. We introduced three tools: (1) the stress ellipsoid, (2) the three principal stress axes, and (3) the stress tensor. The stress ellipsoid is the envelope containing the tails or tips (for compression and tension, respec-

tively) of the stress vectors associated with the infinite number of planes passing through the point, with each of the specified vectors and its opposite associated with one plane. On all but three of these planes the vectors have shear stress components. As a rule, there will be three mutually perpendicular planes on which the shear component is zero; the stress vector acting on each of these planes is perpendicular to the plane. These three planes are called the *principal planes of stress*, and the associated stress vectors are the *principal axes of stress*, or *principal stresses* ($\sigma_1 \geq \sigma_2 \geq \sigma_3$). Like any ellipsoid, the stress ellipsoid has three axes, and the principal stresses lie parallel to these axes. Given the three principal stresses, you have uniquely defined the stress ellipsoid; given the stress ellipsoid, you can calculate the stress acting on any random plane that passes through the center of the ellipsoid (which is the point for which we defined the stress state). So, the stress ellipsoid and the principal stresses give a complete description of the stress at a point. Structural geologists find these tools convenient to work with because they are easy to visualize. Thus we often represent the stress state at a point by picturing the stress ellipsoid, or we talk about the values of the principal stresses at a location. For example, we would say that “the orientation of the maximum principal stress at the New York–Pennsylvania border trends about 070° .”

For calculations, these tools are a bit awkward and a more general description of stress at a point is needed; this tool is the *stress tensor*. The stress tensor consists of the components of three stress vectors, each associated with a face of an imaginary cube centered in a specified Cartesian frame of reference. Each face of the cube contains two of the Cartesian axes. If it so happens that the stress vectors acting on the faces of the cube have no shear components, then by definition they are the principal stresses, and the axes in your Cartesian reference frame are parallel to the principal stresses. But if you keep the stress state constant and rotate the reference frame, then the three stress vectors will have shear components. The components of the three stress vectors projected onto the axes of your reference frame (giving one normal stress and two shear stresses) are written as components in a 3×3 matrix (a second-rank tensor). If the axes of the reference frame happen to be parallel to the principal stresses, then the diagonal terms of the matrix are the principal stresses and the off-diagonal terms are zero (that is, the shear stresses are zero). If the axes have any other orientation, then the diagonal terms are not the principal stresses and some, or all, of the off-diagonal terms are

not equal to zero. When using the three principal stresses or the stress ellipsoid, you are merely specifying a special case of the stress tensor at a point.

3.12 STRESS TRAJECTORIES AND STRESS FIELDS

By connecting the orientation of principal stress vectors at several points in a body, you obtain trajectories that show the variation in orientation of that vector within the body, which are called **stress trajectories**. Generally, stress trajectories for the maximum and minimum principal stresses are drawn, and a change in trend means a change in orientation of these principal stresses. Collectively, principal stress trajectories represent the orientation of the **stress field** in a body. In some cases the magnitude of a particular stress vector is represented by varying the spacing between the trajectories. An example of the stress field in a block that is pushed on one side is shown in Figure 3.13. If the stress at each point in the field is the same in magnitude and orientation, the stress field is *homogeneous*; otherwise it is *heterogeneous*, as in Figure 3.13. Homogeneity and heterogeneity of the stress field should not be confused with isotropic and anisotropic stress. Isotropic means that the principal stresses are equal (describing a sphere), whereas homogeneous stress implies that the orientation and shape of the stress ellipsoids are equal throughout the body. In a homogeneous stress field, all principal stresses have the same orientation and magnitude. The orientation of stress trajectories under natural conditions typically varies, arising from the presence of discontinuities in

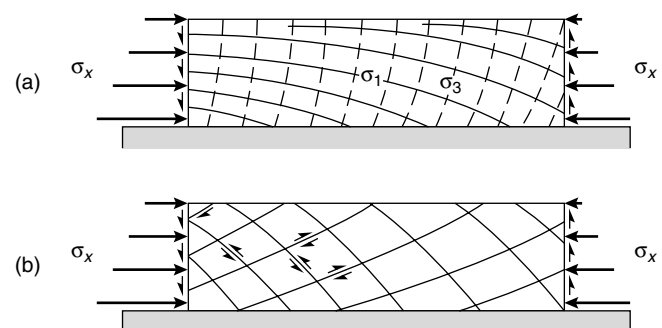

FIGURE 3.13 (a) Theoretical stress trajectories of σ_1 [full lines] and σ_3 [dashed lines] in a block that is pushed from the left resisted by frictional forces at its base. Using the predicted angle between maximum principal stress [σ_1] and fault surface of around 30° [Coulomb failure criterion; Chapter 6] we can predict the orientation of faults, as shown in [b].

TABLE 3.3	SOME STRESS MEASUREMENT METHODS
Borehole breakouts	The shape of a borehole changes after drilling in response to stresses in the host rock. Specifically, the hole becomes elliptical with the long axis of the ellipse parallel to minimum horizontal principal stress ($\sigma_{s, \text{hor}}$).
Hydrofracture	If water is pumped under sufficient pressure into a well that is sealed off, the host rock will fracture. These fractures will be parallel to the maximum principal stress (σ_1), because the water pressure necessary to open the fractures is equal to the minimum principal stress.
Strain release	A strain gauge, consisting of tiny electrical resistors in a thin plastic sheet, is glued to the bottom of a borehole. The hole is drilled deeper with a hollow drill bit (called <i>overcoring</i>), thereby separating the core to which the strain gauge is connected from the wall of the hole. The inner core expands (by elastic relaxation), which is measured by the strain gauge. The direction of maximum elongation is parallel to the direction of maximum compressive stress and its magnitude is proportional to stress according to Hooke's Law (see Chapter 5).
Fault-plane solutions	When an earthquake occurs, records of the first motion on seismographs around the world enable us to divide the world into two sectors of compression and two sectors of tension. These zones are separated by the orientation of two perpendicular planes. One of these planes is the fault plane on which the earthquake occurred, and from the distribution of compressive and tensile sectors, the sense of slip on the fault can be determined. Seismologists assume that the bisector of the two planes in the tensile sector represents the minimum principal stress (σ_3) and the bisector in the compressive field is taken to be parallel to the maximum compressive stress (σ_1).

rocks, the complex interplay of more than one stress field (like gravity), or contrasts in rheology (Chapter 5).

3.13 METHODS OF STRESS MEASUREMENT

Up to this point our discussion of stress has been pretty theoretical, except perhaps for our classroom experiment with clay and the example of kicking a ball around. Before you forget that stress is a physical quantity rather than an abstract concept (as in psychology), we will close this chapter with a few notes on stress measurements and an application. Because the methods of present-day stress measurements are explained in most engineering texts on rock mechanics, the more common methods are briefly described in Table 3.3. At the end of this section we'll offer a few general comments on geologic stress and give a sense of stress magnitudes.

3.13.1 Present-Day Stress

As it turns out, it is quite difficult to obtain a reliable measure of present-day stress in the Earth. The deter-

mination of the absolute magnitude of the stress is particularly challenging. Generally, stress determinations give the stress differences (the differential stress) and the orientation of the principal stresses, using earthquake focal mechanisms, well-bore enlargements (or "breakouts"), and other in situ stress measurements (Table 3.3), and the analysis of faults and fractures. Earthquake focal mechanisms define a set of two possible fault planes and slip vectors, which are assumed to parallel the maximum resolved shear stress on these planes. Several focal mechanisms and slip vectors on faults of different orientation are used to determine the (best-fit) principal stress axes. The magnitude of stress is based on the energy release of earthquakes, but this relationship is incomplete. The analysis of the orientation of exposed faults and their observed slip uses a similar inversion approach. The elliptical distortion of vertical wells that were drilled for petroleum and gas exploration is a direct gauge of the local stress field and is widely available; the long axis of the distortion is parallel to the horizontal, minimum principal stress. Other in situ stress measurements, such as hydraulic fracturing, in which a hole is capped and pressurized by a fluid until fracturing releases the fluid pressure, reflect the local stress field. Whether this local field reflects the regional (or, remote) tectonic stress or merely the conditions surrounding the particular geo-

logic feature, including the role of pore pressure, is a topic of ongoing debate.

We can get an intuitive sense of differential stress magnitudes in nature from a simple consideration of mountainous regions. We have all looked in awe at steep walls of rock, especially when they are scaled by climbers. In the western Himalayas, vertical cliffs rise up to 2000 m above the valleys. Using Equation 3.16, we can calculate the vertical stress at the base of such cliffs is >50 MPa,⁹ while the minimum horizontal stress (that is, atmospheric pressure) is only about 0.1 MPa. Of course mountain ranges of 6–9 km high are not vertical cliffs, so we require a modification of Equation 3.16 to get the differential stress from the load of mountains. Using a triangular load with height h on an elastic medium, we get (without showing the derivation)

$$\sigma_d \approx 0.5 \rho \cdot g \cdot h \quad \text{Eq. 3.17}$$

Given that mountain ranges are up to 9 km in height, this implies differential stresses that exceed 100 MPa.

Present-day stress determinations, like borehole measurements, give differential stress magnitudes that likewise range from tens to hundreds of megapascals. Realize, though, that these methods only record stress magnitudes in the outermost part (upper crust) of Earth (Figure 3.14). The magnitude of differential stresses deep in Earth can only be understood when we know something about Earth's thermal structure and mechanisms of rock deformation, where differential stresses are one to two orders of magnitude less (see Section 3.13.3).

3.13.2 Paleostress

If we wish to determine the ancient stress field from rocks, most of the approaches listed above are not suitable. For the analysis of **paleostress** we are essentially limited to the analysis of fault and fracture data, and to microstructural approaches such as grain-size determinations and grain deformation analysis. Fault-slip analysis requires some understanding of fault mechanics (Chapter 6), but, in short, it uses fault orientation and the sense of slip on that fault with the assumption that the slip direction parallels the maximum shear stress in that plane. Numerical analysis of sufficiently large fault data sets can provide the **reduced stress tensor** that contains the orientations of the three principal stresses and

⁹ $2700 \text{ kg/m}^3 \times 9.8 \text{ m/s}^2 \times 2000 \text{ m} = 53 \text{ MPa}$.

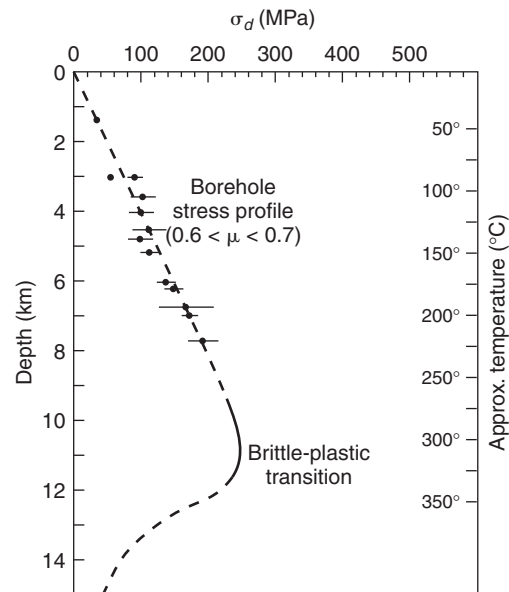

FIGURE 3.14 In situ borehole measurements of differential stress (σ_d) with depth, indicating a friction coefficient (μ) in the range of 0.6–0.7 for the upper crust.

the differential stress ratio, $(\sigma_2 - \sigma_3)/(\sigma_1 - \sigma_2)$, which ranges from 0 (when $\sigma_2 = \sigma_3$) to 1 (when $\sigma_1 = \sigma_2$).

Microstructural methods require an understanding of crystal plastic processes and the development of microstructures that are discussed in Chapter 9. The grain size of plastically deformed rocks appears to be nonlinearly related to the differential stress magnitude, based on laboratory experiments at elevated pressure and temperature conditions. Similarly, the development of deformation microstructures of individual grains, like crystal twins, is a function of the differential stress. Collectively, these approaches broadly constrain the differential stress magnitudes at many depths in Earth, complementing upper crustal data from fault studies and present-day stress determinations. Whereas these methods remain unexplained at this point, some of the information that is obtained from them is incorporated in the final section on stress in Earth.

3.13.3 Stress in Earth

From large data sets of present-day stress measurements we find that the results are generally in good agreement about the orientation of the principal stresses and that they compare reasonably well in magnitude. An application of these approaches and the information that they provide about regional stress patterns and plate dynamics is shown in Figure 3.15. This global synthesis of stress data, part of the World Stress Map

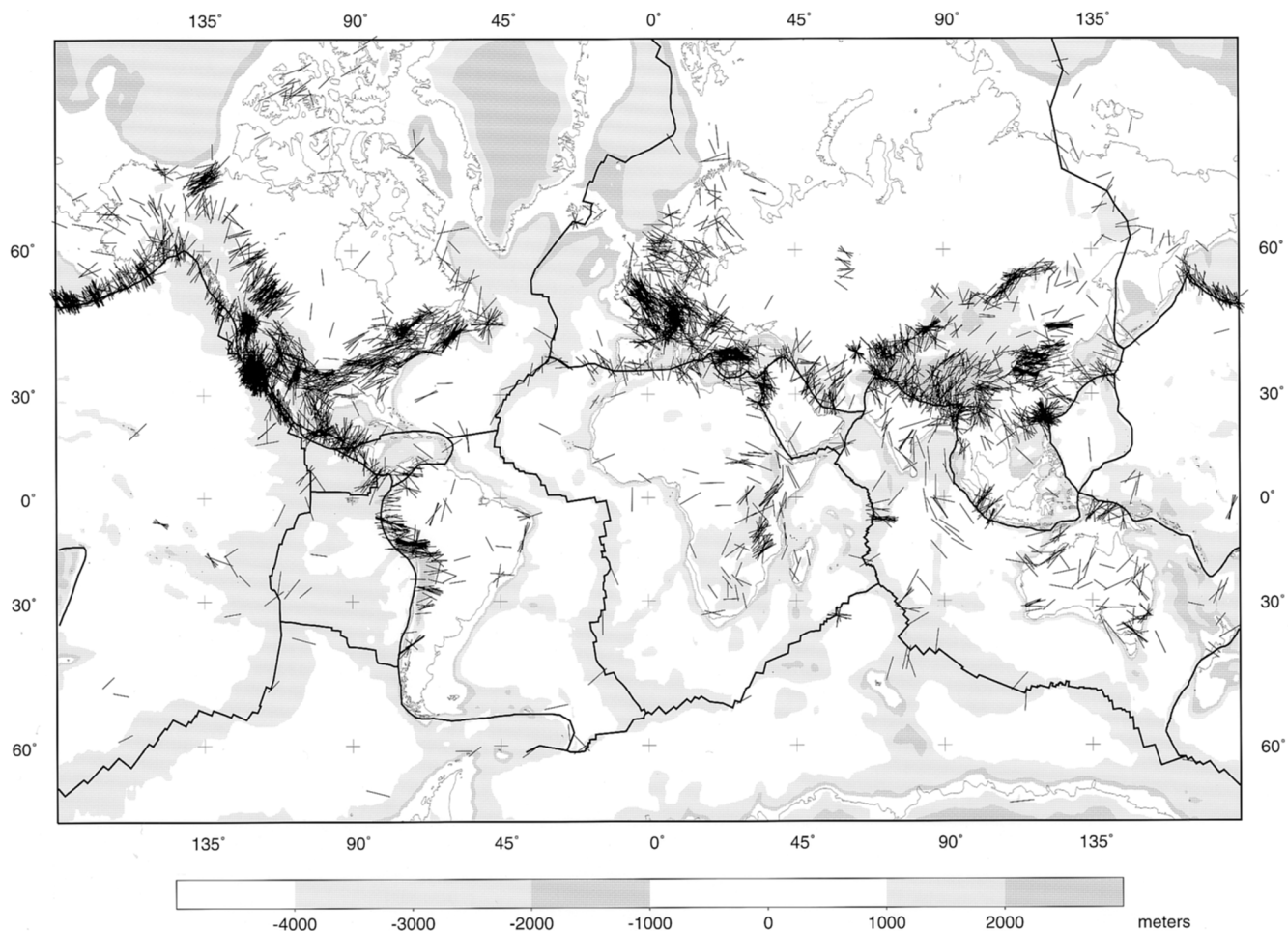

FIGURE 3.15 (a) World Stress Map showing orientations of the maximum horizontal stress superimposed on topography.

project, reflects an international effort that catalogs present-day stress patterns around the world. The majority of stress determinations are from earthquake focal mechanism solutions.

The global stress summary map (Figure 3.15b) shows regionally systematic stress fields in the upper crust, despite the geologic complexity found at Earth's surface. The orientation and magnitudes of horizontal principal stresses are uniform over areas hundreds to thousands of kilometers in extent. These data also show that the upper crust is generally under compression, meaning that maximum compressive stresses are horizontal, resulting in either reverse or strike-slip faulting. For example, the maximum stress in the eastern half of North America is oriented approximately NE–SW with differential stresses on the order of a hundred megapascals. Areas where horizontal tensile stresses dominate are regions of active extension, such as the East African Rift zone, the Basin and Range of western North America, and high plateaus in Tibet and western South America. Using this compilation we can

divide the global stress field into *stress provinces*, which generally correspond to active geologic provinces. From this, a pattern emerges that is remarkably consistent with the broad predictions from the main driving forces of plate tectonics (such as the pull of the downgoing slab in subduction zones and “push” at ocean ridges) and with the effects of plate interactions (such as continent–continent collision). In Chapter 14 we'll revisit the driving forces of plate tectonics. When studying these global patterns you must realize that they only reflect the present-day stress field. Many of the world's geologic provinces reflect ancient tectonic activity, with configurations and processes that are no longer active today, and the present-day global stress pattern is unrelated to this past activity. For example, the orientation of today's compressive stresses in eastern North America reflect the opening of the Atlantic Ocean. They are at a high angle to late Paleozoic compressive stresses, which resulted from compressional Appalachian-Caledonian activity at the margin.

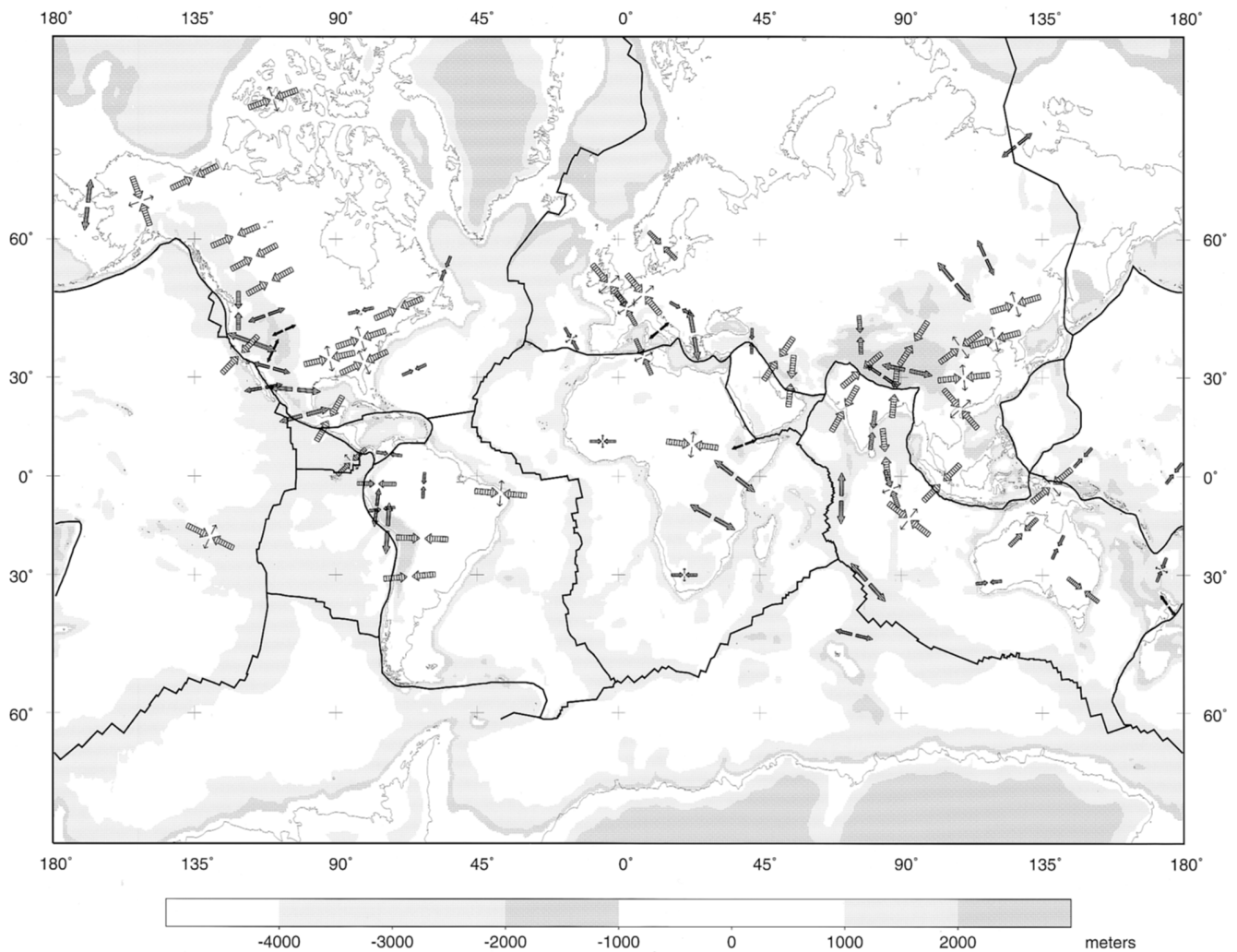

FIGURE 3.15 [Continued.] (b) The generalized pattern based on (a) shows stress trajectories for individual plates; an inward pointing arrow set reflects reverse faulting, an outward pointing arrow set reflects normal faulting, double sets indicate strike-slip faulting.

What happens at depth? While lithostatic pressure increases with depth (see Equation 3.17), differential stress cannot increase without bounds, because the rocks that comprise the Earth do not have infinite strength. **Strength** is the ability of a material to support differential stress; in other words, it is the maximum stress before rocks fail by fracturing or flow. Combining present-day stress and paleostress data with experimental data on flow properties of rocks and minerals (Chapter 9) gives generalized strength profiles for Earth. These **strength curves** represent the differential stress magnitude with depth, given assumptions on the composition and temperature of rocks. At this point we include representative strength curves without much explanation just to give you an idea of stress magnitudes with depth.

You remember from your introductory geology class that the outermost rheologic layer of the Earth is called the **lithosphere**, comprising the crust and part of the upper mantle, which overlies the **asthenosphere**. Taking a quartzo-feldspathic crust and an olivine-rich upper mantle, a low geothermal gradient (about $10^{\circ}\text{C}/\text{km}$), and a crustal thickness of about 40 km, produces the lithospheric strength curve in Figure 3.16a. You will notice that a sharp decrease in strength occurs around 25 km, which reflects the change from brittle to plastic flow (called the *brittle-plastic transition*) in quartzo-feldspathic rocks. The properties of an olivine-rich mantle are quite different from the crust, and this in turn produces a sharp increase in strength and, therefore, a return to brittle behavior at the crust-mantle boundary

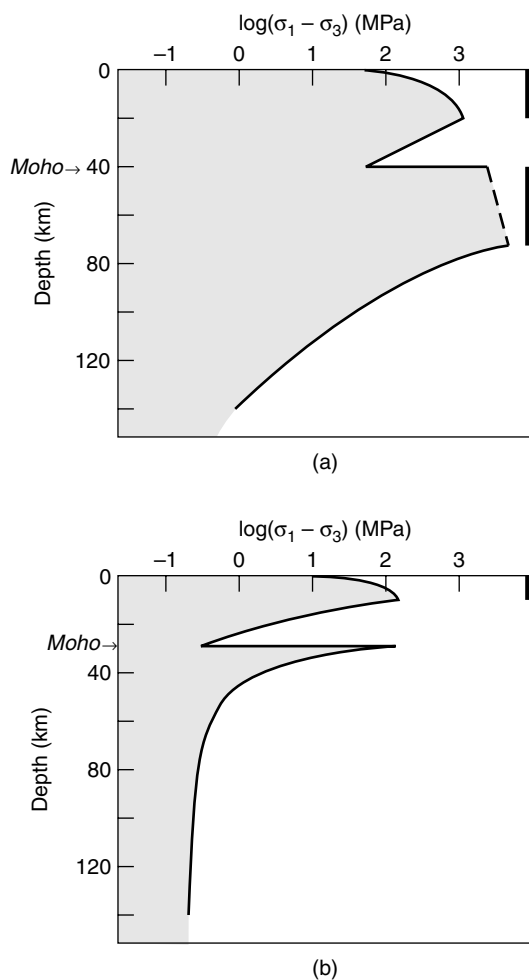

FIGURE 3.16 Strength curves showing the variation in differential stress magnitude with depth in the Earth for (a) a region characterized by a low geothermal gradient (e.g., Precambrian shield areas) and (b) a region with a high geothermal gradient (e.g., areas of continental extension). Differential stresses are largely based on experimental data for brittle failure and ductile flow, which change as a function of composition and temperature. In these diagrams the only compositional change occurs at the crust-mantle boundary (the Moho); in the case of additional compositional stratification, more drops and rises will be present in the strength curve. The bar at the right side of each diagram indicates where seismic activity may occur.

(the Moho). As with the crustal profile, strength decreases as plastic behavior replaces the brittle regime of mantle rocks with depth. This brittle versus plastic behavior of rock is strongly dependent on temperature, as demonstrated by creating a strength profile at a higher geothermal gradient (Figure 3.16b), which promotes plastic flow and reduces the strength up to one order of magnitude. With a geothermal gradient

of 20°C/km, the brittle–plastic transition now occurs at a depth of about 10 km. In all cases the deeper mantle is mechanically weak, because it is characterized by high temperatures, meaning that the mantle only supports differential stresses on the order of a few megapascals. When considering strength profiles, remember the distinction between differential stress and lithostatic pressure. The lithostatic pressure always becomes greater with depth in the Earth, and is orders of magnitude greater than the differential stress. For example, the lithostatic stress at a depth of 100 km in the Earth is several thousand megapascals (use Equation 3.16), but the differential stress is only on the order of 1–10 MPa!

3.14 CLOSING REMARKS

Dynamic analysis, the study of stresses in a body, is a topic whose relevance goes well beyond structural geology. Societal challenges like building collapse and mass wasting come to mind as examples of phenomena whose disastrous effects can be minimized by adequate knowledge of stress states. In this chapter you have learned the fundamentals of force and stress, and obtained an intuitive sense of the meaning of stresses on a body, the stress ellipsoid, and stress conditions in Earth. A more quantitative analysis of the material is left for advanced texts (see reading list). Throughout this book we mainly focus on the general relationship (or lack thereof) between the geometry of geologic structures and their origins. Although many aspects of dynamic analysis remained unmentioned in this chapter, you now have the basic tools needed for the next step in our journey: the analysis of deformation and strain.

ADDITIONAL READING

- Anderson, D. L., 1989. *Theory of the Earth*. Blackwell Scientific: Oxford.
- Angelier, J., 1994. Fault slip analysis and Paleostress reconstruction. In Hancock, P. L., ed., *Continental deformation*. Pergamon, pp. 53–100.
- Engelder, T., 1993. *Stress regimes in the lithosphere*. Princeton University Press.
- Jaeger, J. C., and Cook, N. G. W., 1976. *Fundamentals of rock mechanics*. Chapman and Hall: London.

Means, W. D., 1976. *Stress and strain—basic concepts of continuum mechanics for geologists*. Springer-Verlag: New York.

Nye, J. F., 1985. *Physical properties of crystals, their representation by tensors and matrices* (2nd edition). Oxford University Press: Oxford.

Turcotte, D. L., and Schubert, G., 1982. *Geodynamics—applications of continuum physics to geological problems*. J. Wiley & Sons: New York.

Zoback, M. L., 1992. First and second order patterns of stress in the lithosphere: the World Stress Map project. *J. Geophysical Research*, 97, 11703–11728.